

General Specifications	
Operating Temperature	0° to 60°C (32° to 140°F)
Storage Temperature	-20° to 70°C (-4° to 158°F)
Humidity	5 to 95% (non-condensing)
Environmental Air	No corrosive gases permitted
Vibration	IEC60068-2-6 (Test Fc)
Shock	IEC60068-2-27 (Test Ea)
Enclosure Type	Open Equipment
Agency Approvals	UL 61010-1 and UL 61010-2-201 File E139594, Canada and USA CE (EN 61131-2 EMC, EN 61010-1 and EN 61010-2-201 Safety)
Noise Immunity	NEMA ICS3-304
EU Directive	See the "EU Directive" topic in the BRX Help File.
Weight	110g (3.9 oz)
Heat Dissipation	3.75W
Software Version Required	Do-more! Designer Version 2.6, or later.

\*Meets EMC and Safety requirements. See the D.O.C. for details.

Module Power	
Backplane Power Consumption	0.3W
External DC Power Required	Class 2 or LPS power supply 24VDC (±20%) 100mA

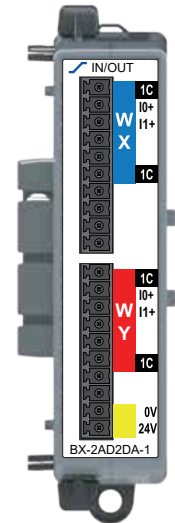
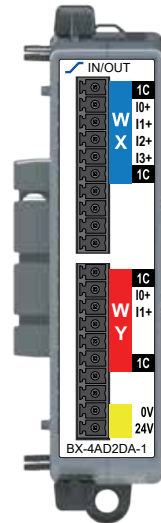

## BX-4AD2DA-1

Analog Input/Output  
Combo Expansion Module

4-ch In, 2-ch Out,  
0-20mA/4-20mA

## BX-2AD2DA-1

Analog Input/Output  
Combo Expansion Module

2-ch In, 2-ch Out,  
0-20mA/4-20mA

I/O Terminal Blocks sold separately. (See Connector Options Spec. table inside.)

Analog Current Sinking Input/Output Specifications		
	INPUT	OUTPUT
Points per Module – BX-4AD2DA-1	4	2
Points per Module – BX-2AD2DA-1	2	2
Commons	1	
Module Signal Range	0-20mA, 4-20mA (Default)	
Signal Resolution	16 bit, 15 bit (Default)	
Resolution Value of LSB (least significant bit) (@ 16 bit resolution)	(1 LSB = 1 count) 0-20mA = 0.305µA 4-20mA = 0.244µA	
Input Impedance	256Ω±0.1%, 1/10th watt	N/A
All Channel Update Rate	BX-4AD2DA-1 45ms (4 Channels)	2.5ms per enabled channel
	BX-2AD2DA-1 30ms (2 Channels)	2.5ms per enabled channel
Output type	N/A	
Output Value in Fault Mode	N/A	
Maximum Load Impedance	N/A	
Maximum Capacitive Load	N/A	
Allowed Load Type	N/A	
Maximum Continuous Overload	±28mA	30mA
Sample Duration Time	100µs per channel	N/A
Hardware Filter Characteristics	Low Pass 2nd order, -3dB @ 15KHz	N/A
Conversion Method	Successive approximation	
Linearity Error (end to end)	±0.09% of range	±0.08% of range
Stability and Repeatability (% full range after 10 minute warmup)	±0.05%	±0.03% (Typical)
Full Scale Calibration Error	±0.1% of range	±0.08% of range (Max.)
Offset Calibration Error	±0.1% of range	±0.08% of range (Max.)
Accuracy vs. Temperature	±25PPM / °C maximum	
Maximum Inaccuracy	0.1% of range (inc. Temp drift)	±0.1% of range
Maximum Crosstalk	-90dB, 1 LSB	+10µV
Output Ripple	N/A	±0.03% of range/mA
Output Settling Time	N/A	350µs
Channel to Backplane Isolation	1800VAC applied for 1 second	
Channel to Channel Isolation	None	
Loop Fusing (external)	Fast-acting 0.032A recommended	

**WARNING:** To minimize the risk of potential safety problems, you should follow all applicable local and national codes that regulate the installation and operation of your equipment. These codes vary from area to area and it is your responsibility to determine which codes should be followed, and to verify that the equipment, installation, and operation are in compliance with the latest revision of these codes.

**Equipment damage or serious injury to personnel can result from the failure to follow all applicable codes and standards. We do not guarantee the products described in this publication are suitable for your particular application, nor do we assume any responsibility for your product design, installation, or operation.**

If you have any questions concerning the installation or operation of this equipment, or if you need additional information, please call Technical Support at 770-844-4200.

This publication is based on information that was available at the time it was printed. At AutomationDirect.com® we constantly strive to improve our products and services, so we reserve the right to make changes to the products and/or publications at any time without notice and without any obligation. This publication may also discuss features that may not be available in certain revisions of the product.

Do-more BRX Manual available at  
<http://www.automationdirect.com/pn/doc/manual/BX-USER-M>



### IMPORTANT!



#### Hot-Swapping Information

**Note: This device cannot be Hot Swapped.**

Document Name	Edition/Revision	Date
BX-xAD2DA-1	1st Ed. RevA	11/3/2020

Copyright 2021, AutomationDirect.com Incorporated/All Rights Reserved Worldwide.

## Connector Options Specifications

<b>BX-RTB10</b>	Terminal Block Kit, 90-degree screw type. For use with BRX 10-point PLCs, BRX 16-point expansion modules and all analog and temperature expansion modules. Kit includes (2) 10-pin 3.8mm plugs.
<b>BX-RTB10-1</b>	Terminal Block Kit, 180-degree spring clamp type. For use with BRX 10-point PLCs, BRX 16-point expansion modules. Kit includes (2) 10-pin 3.8mm plugs.
<b>BX-RTB10-2</b>	Terminal Block Kit, 180-degree screw type. For use with BRX 10-point PLCs, BRX 16-point expansion modules and all analog and temperature expansion modules. Kit includes (2) 10-pin 3.8mm plugs.
<b>ZL-BXEM-CBL20</b>	ZIPLink PLC I/O cable, 20-position terminal block to 24-pin connector, 24AWG, cable length 0.5 meter (1.6ft). For use with BRX 16-point expansion modules.
<b>ZL-BXEM-CBL20-1</b>	ZIPLink PLC I/O cable, 20-position terminal block to 24-pin connector, 24AWG, cable length 1meter (3.3ft). For use with BRX 16-point expansion modules.
<b>ZL-BXEM-CBL20-2</b>	ZIPLink PLC I/O cable, 20-position terminal block to 24-pin connector, 24AWG, cable length 2meter (6.6ft). For use with BRX 16-point expansion modules.
<b>ZL-BXEM-CBL20-1P</b>	ZIPLink PLC I/O cable, 20-position terminal block to pigtail connection, 24AWG, cable length 1meter (3.3ft). For use with BRX 16-point expansion modules.
<b>ZL-BXEM-CBL20-2P</b>	ZIPLink PLC I/O cable, 20-position terminal block to pigtail connection, 24AWG, cable length 2meter (6.6ft). For use with BRX 16-point expansion modules.
<b>ZL-RTB20</b>	ZIPLink Two Level Feedthrough Module, 20-pole, 35mm, DIN mount.
<b>ZL-RTB20-1</b>	ZIPLink Three Level Feedthrough Module, 20-pole, 35mm, DIN mount.

## Terminal Block Connector Specifications

Part Number	BX-RTB10	BX-RTB10-1	BX-RTB10-2
Connector Type	Screw Type-90°	Spring Clamp Type-180°	Screw Type-180°
Pitch	3.81mm	3.81mm	3.81mm
Recommended Screw torque	<1.77 lb-in (0.2 N·m)	N/A	<1.77 lb-in (0.2 N·m)
Screwdriver Blade Width	2.5mm	2.5mm	2.5mm
Equiv. Dinkle part #	EC381V-10P-BK	ESC381V-10-BK	EC381F-10P-BK

## Module Installation

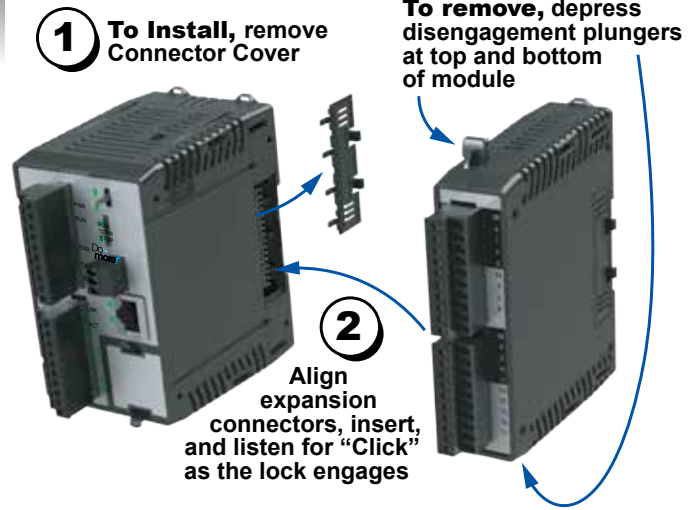

## Dimensional Information

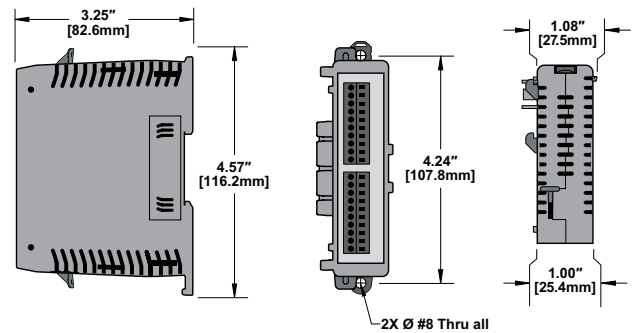

## I/O Wiring

### Terminal Block Output Wiring

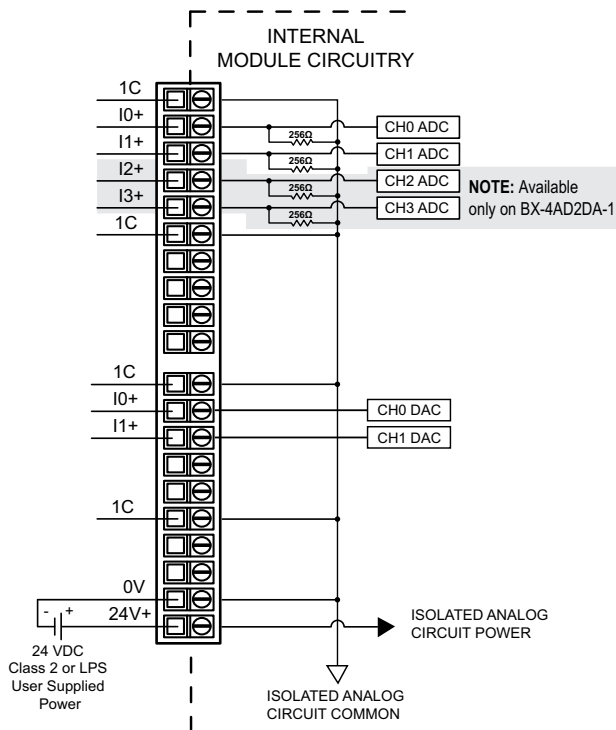

## I/O Wiring

### Analog Current Sinking Input Circuits

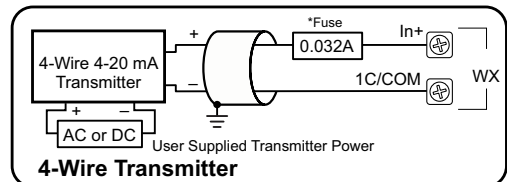
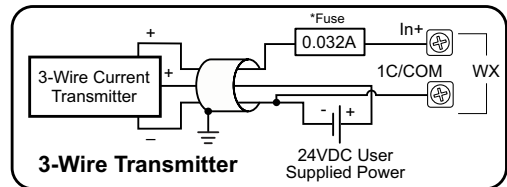
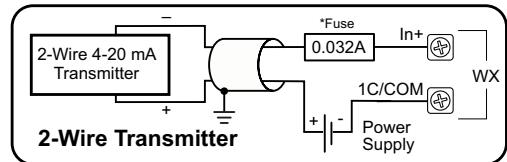

### Analog Current Source Output

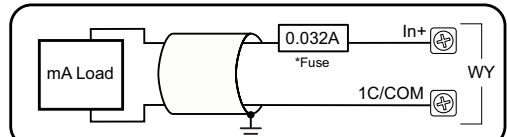

\*An Edison S500-32-R 0.032A fast-acting fuse is recommended for all analog voltage inputs, analog outputs, and current loops.  
NOTE: Shield should be connected only at one end, to ground at the source device.