

# INSTALLATION & WIRING

---

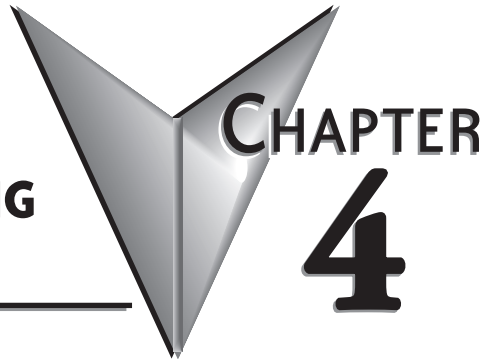

## In This Chapter...

Safety Guidelines .....	4-2
Introduction .....	4-3
Panel Cutout Dimensions (all models) .....	4-4
Wiring Guidelines .....	4-5

# Safety Guidelines



**NOTE:** *Products with CE marks perform their required functions safely and adhere to relevant standards as specified by CE directives provided they are used according to their intended purpose and that the instructions in this manual are adhered to. The protection provided by the equipment may be impaired if this equipment is used in a manner not specified in this manual. A listing of our international affiliates is available on our Web site: <http://www.automationdirect.com>*

4



**WARNING:** Providing a safe operating environment for personnel and equipment is your responsibility and should be your primary goal during system planning and installation. Automation systems can fail and may result in situations that can cause serious injury to personnel or damage to equipment. Do not rely on the automation system alone to provide a safe operating environment. You should use external electromechanical devices, such as relays or limit switches, that are independent of the PLC application to provide protection for any part of the system that may cause personal injury or damage. Every automation application is different, so there may be special requirements for your particular application. Make sure you follow all national, state, and local government requirements for the proper installation and use of your equipment.

## Plan for Safety

The best way to provide a safe operating environment is to make personnel and equipment safety part of the planning process. You should examine *every* aspect of the system to determine which areas are critical to operator or machine safety. If you are not familiar with control system installation practices, or your company does not have established installation guidelines, you should obtain additional information from the following sources.

- NEMA — The National Electrical Manufacturers Association, located in Washington, D.C. publishes many different documents that discuss standards for industrial control systems. You can order these publications directly from NEMA. Some of these include:

*ICS 1, General Standards for Industrial Control and Systems*

*ICS 3, Industrial Systems*

*ICS 6, Enclosures for Industrial Control Systems*

- NEC — The National Electrical Code provides regulations concerning the installation and use of various types of electrical equipment. Copies of the NEC Handbook can often be obtained from your local electrical equipment distributor or your local library.
- Local and State Agencies — many local governments and state governments have additional requirements above and beyond those described in the NEC Handbook. Check with your local Electrical Inspector or Fire Marshall office for information.

## Introduction

The installation and wiring of *C-more* 6" Micro-Graphic panels require selecting an appropriate location for the panel, laying out the cutout dimensions on the surface of the control cabinet that the panel will be mounted through, securing the panel with the provided mounting clips, tightening the screws to the appropriate torque rating to assure the gasket is sealing correctly, and finally connecting the appropriate power source to the panel.



**NOTE:** Each *C-more* 6" Micro-Graphic panel is provided with a cutout template to simplify marking the proper cutout size on the surface of the control cabinet that the panel will be mounted through. The keypad bezels are also provided with an appropriate cutout template for mounting convenience.

The *C-more* 6" Micro-Graphic panels include four mounting clips. They are fitted to the panel by inserting two tabs into mating slots on the panel and then sliding the clip into a narrower slot to secure it in place.

If using the panel with a Keypad Bezel, then install the panel into the keypad bezel and secure with the mounting clips that are provided with the panel to seal the panel gasket. Create a cutout in the enclosure that the assembled panel and keypad bezel will be mounted through and secure the assembly with the mounting clips that are provided with the keypad bezel. See **Chapter 3: Accessories** for additional details.

### Mounting Clips EA-MG-BZ2-BRK



**NOTE:** The *C-more* 6" Micro-Graphic panel (EA1-S6ML & EA1-S6MLW), 20-Button Keypad Bezel (EA-MG6-BZ2) and 21-Button Keypad Bezel (EA-MG6-BZ2P) use the same type of mounting clip (EA-MG-BZ2-BRK).

## Panel Cutout Dimensions (all models)

The *C-more* 6" Micro-Graphic panel is mounted into a cutout through the control cabinet and secured with four (4) mounting clips. The mounting clips are provided with the panel. There are slots on each side of the panel's long dimension that the two tabs on each mounting clip will match. The mounting clips are held in place by inserting the tabs into the "T" shaped holes (slots) and then moving the mounting clip toward the rear of the panel to keep it in place. Next tighten the mounting clip screws to pull the rear of the panel's bezel to the control cabinet's mounting surface. The screws need to be tightened to the torque rating shown in the illustration below so that the gasket is compressed to form the proper seal between the panel and cabinet surface.

4

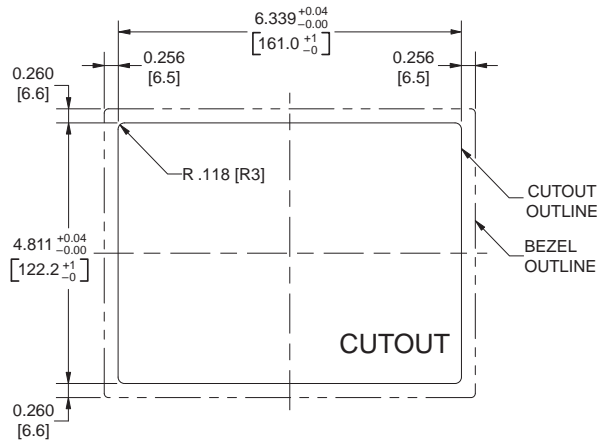

### Enclosure Mounting Thickness Ranges and Mounting Bracket Screw Torque

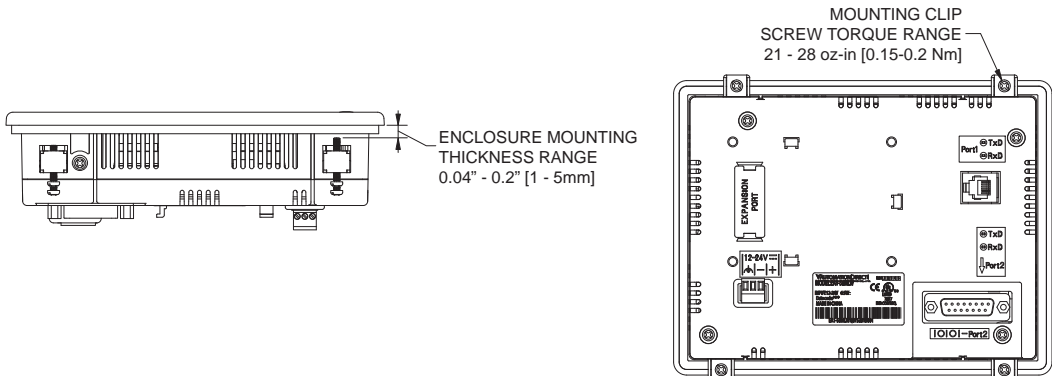

## Wiring Guidelines



**WARNING:** To minimize the risk of potential safety problems, you should follow all applicable local and national codes that regulate the installation and operation of your equipment. These codes vary from area to area and it is your responsibility to determine which codes should be followed, and to verify that the equipment, installation, and operation are in compliance with the latest revision of these codes. Equipment damage or serious injury to personnel can result from the failure to follow all applicable codes and standards. We do not guarantee the products described in this publication are suitable for your particular application, nor do we assume any responsibility for your product design, installation, or operation.

If you have any questions concerning the installation or operation of this equipment, or if you need additional information, please call us at 1-800-633-0405 or 770-844-4200.

This publication is based on information that was available at the time it was printed. At AutomationDirect.com® we constantly strive to improve our products and services, so we reserve the right to make changes to the products and/or publications at any time without notice and without obligation. This publication may also discuss features that may not be available in certain revisions of the product.

### Providing Power to the *C-more* 6" Micro-Graphic Panel

Power can be supplied to the *C-more* Micro-Graphic panel in one of three different ways.

- 1.) The *C-more* 6" Micro-Graphic panel is powered during programming from the PC through the USB to RS-232 Programming Cable Assembly, EA-MG-PGM-CBL. The panel will operate in Low-Power mode when powered by the PC and result in a dim screen.
- 2.) During operation, the 6" panel functions in High-Power Mode when supplied powered by a minimum 1 Amp 12 - 24 VDC class 2 power source. Recommended power supplies are AutomationDirect part number PSC-24-015 or PSC-24-030.
- 3.) During operation, the *C-more* 6" Micro-Graphic panel can function in Low-Power Mode powered from most *AutomationDirect* PLC's RJ12 serial communications port. Use a DV-1000CBL communications cable, or a DV-1000CBL communications cable with a FA-15HD 15-pin HD DSub/RJ12 Adapter connected to most AutomationDirect PLC's 15-pin HD communications port (DL06, D2-250-1 & D2-260) PLCs for Low-Power operation. See **Chapter 6: PLC Communications** for additional details. The panel will operate in low-power mode when powered by the PC.



**NOTE:** When the 6" panel is powered through Port1 from a connected PLC or PC, the screen brightness is diminished because the panel is running in **Low-Power Mode**. For full brightness, connect an external 12-24 VDC class 2 power source to the panel's power connection. **Low-Power Mode** is intended for initial programming. For full brightness, connect an external 12-24 VDC class 2 power source when the panel is installed in its application.

Wiring Guidelines continued at top of the next page.

## Wiring Guidelines (cont'd)

### Panel Powered from AutomationDirect PLC via Communications Cable

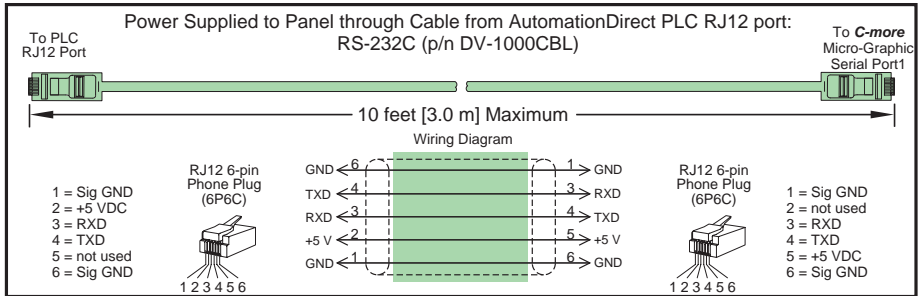

**NOTE:** Maximum cable length when the panel is powered via a PLC is 10 feet.

**NOTE:** Only one C-more Micro-Graphic panel can be powered by a CLICK PLC. If a 2nd panel is connected to a different port on the CLICK PLC, an external power supply is required.

Wiring Guidelines continued at top of the next page.

# Wiring Guidelines (cont'd)

## Panel Powered from an external DC Power Supply – Wiring Diagrams

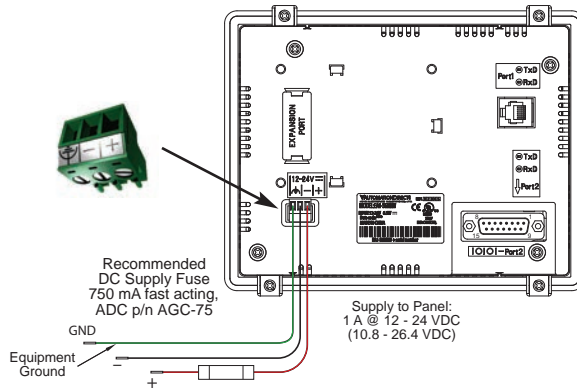

Tightening Torque	
Power supply wire connection	1.7 lb-in (0.2 Nm)

Required Wire Specification	
Supported temperature	Over 60 °C
Wire Material	Copper
Wire Size	16 - 22 AWG



**NOTE:** Recommended DC power supply, **AutomationDirect** Part No. PSC-24-015 or PSC-24-030.

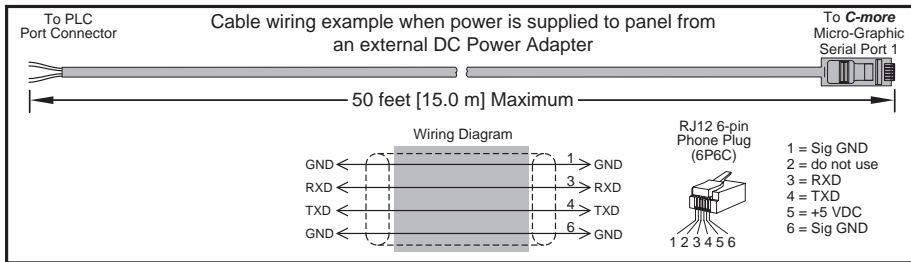

## Maximum communication cable length when powered from an external DC Power Adapter



**NOTE:** When the 6" panel is powered through Port1 from a connected PLC or PC, the screen brightness is diminished because the panel is running in **Low-Power Mode**. For full brightness, connect an external 12-24 VDC power source to the panel's power connection. **Low-Power Mode** is intended for initial programming. For full brightness, connect an external 12-24 VDC power source when the panel is installed in its application.