

# GS2 Series Drives User Manual

# GS2

## AC DRIVE

115V Input: 0.25 - 1.0 hp

230V Input: 0.5 - 7.5 hp

460V Input: 1.0 - 10 hp

575V Input: 1.0 - 10 hp



**Automation  
Direct®**



# ⚡ WARNING ⚡

Thank you for purchasing automation equipment from Automationdirect.com®, doing business as AutomationDirect. We want your new automation equipment to operate safely. Anyone who installs or uses this equipment should read this publication (and any other relevant publications) before installing or operating the equipment.

To minimize the risk of potential safety problems, you should follow all applicable local and national codes that regulate the installation and operation of your equipment. These codes vary from area to area and usually change with time. It is your responsibility to determine which codes should be followed, and to verify that the equipment, installation, and operation is in compliance with the latest revision of these codes.

At a minimum, you should follow all applicable sections of the National Fire Code, National Electrical Code, and the codes of the National Electrical Manufacturer's Association (NEMA). There may be local regulatory or government offices that can also help determine which codes and standards are necessary for safe installation and operation.

Equipment damage or serious injury to personnel can result from the failure to follow all applicable codes and standards. We do not guarantee the products described in this publication are suitable for your particular application, nor do we assume any responsibility for your product design, installation, or operation.

Our products are not fault-tolerant and are not designed, manufactured or intended for use or resale as on-line control equipment in hazardous environments requiring fail-safe performance, such as in the operation of nuclear facilities, aircraft navigation or communication systems, air traffic control, direct life support machines, or weapons systems, in which the failure of the product could lead directly to death, personal injury, or severe physical or environmental damage ("High Risk Activities"). AutomationDirect specifically disclaims any expressed or implied warranty of fitness for High Risk Activities.

For additional warranty and safety information, see the Terms and Conditions section of our catalog. If you have any questions concerning the installation or operation of this equipment, or if you need additional information, please call us at 770-844-4200.

This publication is based on information that was available at the time it was printed. At AutomationDirect we constantly strive to improve our products and services, so we reserve the right to make changes to the products and/or publications at any time without notice and without any obligation. This publication may also discuss features that may not be available in certain revisions of the product.

## Trademarks

This publication may contain references to products produced and/or offered by other companies. The product and company names may be trademarked and are the sole property of their respective owners. AutomationDirect disclaims any proprietary interest in the marks and names of others.

**Copyright 2004, Automationdirect.com® Incorporated  
All Rights Reserved**

No part of this manual shall be copied, reproduced, or transmitted in any way without the prior, written consent of Automationdirect.com® Incorporated. AutomationDirect retains the exclusive rights to all information included in this document.

# ⚡ AVERTISSEMENT ⚡

Nous vous remercions d'avoir acheté l'équipement d'automatisation de Automationdirect.com®, en faisant des affaires comme AutomationDirect. Nous tenons à ce que votre nouvel équipement d'automatisation fonctionne en toute sécurité. Toute personne qui installe ou utilise cet équipement doit lire la présente publication (et toutes les autres publications pertinentes) avant de l'installer ou de l'utiliser.

Afin de réduire au minimum le risque d'éventuels problèmes de sécurité, vous devez respecter tous les codes locaux et nationaux applicables régissant l'installation et le fonctionnement de votre équipement. Ces codes diffèrent d'une région à l'autre et, habituellement, évoluent au fil du temps. Il vous incombe de déterminer les codes à respecter et de vous assurer que l'équipement, l'installation et le fonctionnement sont conformes aux exigences de la version la plus récente de ces codes.

Vous devez, à tout le moins, respecter toutes les sections applicables du Code national de prévention des incendies, du Code national de l'électricité et des codes de la National Electrical Manufacturer's Association (NEMA). Des organismes de réglementation ou des services gouvernementaux locaux peuvent également vous aider à déterminer les codes ainsi que les normes à respecter pour assurer une installation et un fonctionnement sûrs.

L'omission de respecter la totalité des codes et des normes applicables peut entraîner des dommages à l'équipement ou causer de graves blessures au personnel. Nous ne garantissons pas que les produits décrits dans cette publication conviennent à votre application particulière et nous n'assumons aucune responsabilité à l'égard de la conception, de l'installation ou du fonctionnement de votre produit.

Nos produits ne sont pas insensibles aux défaillances et ne sont ni conçus ni fabriqués pour l'utilisation ou la revente en tant qu'équipement de commande en ligne dans des environnements dangereux nécessitant une sécurité absolue, par exemple, l'exploitation d'installations nucléaires, les systèmes de navigation aérienne ou de communication, le contrôle de la circulation aérienne, les équipements de survie ou les systèmes d'armes, pour lesquels la défaillance du produit peut provoquer la mort, des blessures corporelles ou de graves dommages matériels ou environnementaux («activités à risque élevé»). La société AutomationDirect nie toute garantie expresse ou implicite d'aptitude à l'emploi en ce qui a trait aux activités à risque élevé.

Pour des renseignements additionnels touchant la garantie et la sécurité, veuillez consulter la section Modalités et conditions de notre documentation. Si vous avez des questions au sujet de l'installation ou du fonctionnement de cet équipement, ou encore si vous avez besoin de renseignements supplémentaires, n'hésitez pas à nous téléphoner au 770-844-4200.

Cette publication s'appuie sur l'information qui était disponible au moment de l'impression. À la société AutomationDirect, nous nous efforçons constamment d'améliorer nos produits et services. C'est pourquoi nous nous réservons le droit d'apporter des modifications aux produits ou aux publications en tout temps, sans préavis ni quelque obligation que ce soit. La présente publication peut aussi porter sur des caractéristiques susceptibles de ne pas être offertes dans certaines versions révisées du produit.

## Marques de commerce

La présente publication peut contenir des références à des produits fabriqués ou offerts par d'autres entreprises. Les désignations des produits et des entreprises peuvent être des marques de commerce et appartiennent exclusivement à leurs propriétaires respectifs. AutomationDirect nie tout intérêt dans les autres marques et désignations.

**Copyright 2004, Automationdirect.com® Incorporated  
Tous droits réservés**

Nulle partie de ce manuel ne doit être copiée, reproduite ou transmise de quelque façon que ce soit sans le consentement préalable écrit de la société Automationdirect.com® Incorporated. AutomationDirect conserve les droits exclusifs à l'égard de tous les renseignements contenus dans le présent document.

# ⚡ WARNING ⚡



---

**Warning:** Read this manual thoroughly before using GS2 Series AC Motor Drives.

---



---

**WARNING:** AC input power must be disconnected before performing any maintenance. Do not connect or disconnect wires or connectors while power is applied to the circuit. Maintenance must be performed only by a qualified technician.

---



---

**WARNING:** There are highly sensitive MOS components on the printed circuit boards, and these components are especially sensitive to static electricity. To avoid damage to these components, do not touch these components or the circuit boards with metal objects or your bare hands.

---



---

**WARNING:** A charge may still remain in the DC-link capacitor with hazardous voltages, even if the power has been turned off. To avoid personal injury, do not remove the cover of the AC drive until all "DISPLAY LED" lights on the digital keypad are off. Please note that there are live components exposed within the AC drive. Do not touch these live parts.

---



---

**WARNING:** Ground the GS2 AC Drive using the ground terminal. The grounding method must comply with the laws of the country where the AC drive is to be installed. Refer to "Basic Wiring Diagram" in CHAPTER 2.

---



---

**WARNING:** The mounting enclosure of the AC drive must comply with EN50178. Live parts shall be arranged in enclosures or located behind barriers that meet at least the requirements of the Protective Type IP20. The top surface of the enclosures or barrier that is easily accessible shall meet at least the requirements of the Protective Type IP40. Users must provide this environment for GS2 Series AC Drive.

---



---

**Warning:** The AC drive may be destroyed beyond repair if incorrect cables are connected to the input/output terminals. Never connect the AC drive output terminals T1, T2, and T3 directly to the AC main circuit power supply.

---



# GS2 SERIES AC DRIVE USER MANUAL

Please include the Manual Number and the Manual Issue, both shown below, when communicating with Technical Support regarding this publication.

**Manual Number:** GS2-M  
**Issue:** First Edition, Revision C  
**Issue Date:** 12/2006

| Publication History       |         |  |
|---------------------------|---------|--|
| Issue                     | Date    | Description of Changes   |
| First Edition             | 6/07/02 | Original   |
| First Edition, Revision A | 6/30/03 | Made minor changes throughout.<br>Update for Firmware Version 1.04<br>Added parameter 7.00 (PID) functionality.  |
| First Edition, Revision B | 1/28/05 | Added 115V drives; Made minor changes throughout.  |
| First Edition, Revision C | 12/2006 | Added 575V drives and accessories; Added Ch1 Drives Purpose section; Added short circuit withstand specifications and notes; Changed Ch5 DL PLC control program example; Added new AppxB PLC analog modules; Miscellaneous clarification revisions throughout. |

# TABLE OF CONTENTS

---



|   |      |
|---|------|
| Getting Started . . . . .                 | 1-1  |
| Manual Overview . . . . .                 | 1-2  |
| GS2 AC Drive Introduction . . . . .       | 1-3  |
| GS2 AC Drive Specifications . . . . .     | 1-5  |
| Installation and Wiring . . . . .         | 2-1  |
| Ambient Conditions . . . . .              | 2-2  |
| Installation . . . . .                    | 2-3  |
| Dimensions . . . . .                      | 2-4  |
| GS2 Circuit Connections . . . . .         | 2-6  |
| External Accessories . . . . .            | 2-12 |
| Keypad Operation and Quickstart . . . . . | 3-1  |
| The GS2 Digital Keypad . . . . .          | 3-2  |
| GS2 Quickstart . . . . .                  | 3-6  |
| AC Drive Parameters . . . . .             | 4-1  |
| GS2 Parameter Summary . . . . .           | 4-2  |
| Detailed Parameter Listings . . . . .     | 4-11 |
| Motor Parameters . . . . .                | 4-11 |
| Ramp Parameters . . . . .                 | 4-13 |
| Volts/Hertz Parameters . . . . .          | 4-19 |
| Digital Parameters . . . . .              | 4-22 |
| Analog Parameters . . . . .               | 4-32 |
| Preset Parameters . . . . .               | 4-41 |
| Protection Parameters . . . . .           | 4-43 |
| PID Parameters . . . . .                  | 4-51 |
| Display Parameters . . . . .              | 4-55 |
| Communication Parameters . . . . .        | 4-56 |

---

|  |      |
|--|------|
| GS2 Modbus Communications . . . . .                      | 5-1  |
| Communication Parameters Summary . . . . .               | 5-2  |
| GS2 Parameter Memory Addresses . . . . .                 | 5-4  |
| GS2 Status Addresses . . . . .                           | 5-9  |
| Communicating with <i>DirectLogic</i> PLCs . . . . .     | 5-12 |
| Communicating with Third-party Devices . . . . .         | 5-30 |
| Maintenance and Troubleshooting . . . . .                | 6-1  |
| Maintenance and Inspection . . . . .                     | 6-2  |
| Troubleshooting . . . . .                                | 6-3  |
| Accessories . . . . .                                    | A-1  |
| Accessories Part Numbering . . . . .                     | A-2  |
| Line Reactors . . . . .                                  | A-2  |
| Braking Resistors . . . . .                              | A-8  |
| EMI Input Filters . . . . .                              | A-10 |
| RF Filters . . . . .                                     | A-16 |
| Fuses and Fuse Kits . . . . .                            | A-17 |
| GS-EDRV Ethernet Interface . . . . .                     | A-20 |
| GS Drive Configuration Software . . . . .                | A-22 |
| Miscellaneous Accessories . . . . .                      | A-25 |
| Using GS2 AC Drives with DirectLOGIC PLCs . . . . .      | B-1  |
| Compatible <i>DirectLogic</i> PLCs and Modules . . . . . | B-2  |
| Typical Connections to the GS2 Series AC Drive . . . . . | B-7  |
| Index . . . . .  | I-1  |



# GETTING STARTED

---



## In This Chapter...

|  |     |
|--|-----|
| Manual Overview . . . . .              | 1-2 |
| Overview of this Publication . . . . . | 1-2 |
| Who Should Read This Manual . . . . .  | 1-2 |
| Supplemental Publications . . . . .    | 1-2 |
| Technical Support . . . . .            | 1-2 |
| Special Symbols . . . . .              | 1-2 |
| GS2 AC Drive Introduction . . . . .    | 1-3 |
| Purpose of AC Drives . . . . .         | 1-3 |
| Unpacking . . . . .                    | 1-3 |
| Model Explanation: . . . . .           | 1-3 |
| Nameplate Information: . . . . .       | 1-3 |
| External Parts and Labels: . . . . .   | 1-4 |
| GS2 AC Drive Specifications . . . . .  | 1-5 |

## Manual Overview

### Overview of this Publication

The GS2 AC Drive User Manual describes the installation, configuration, and methods of operation of the GS2 Series AC Drive.

### Who Should Read This Manual

This manual contains important information for those who will install, maintain, and/or operate any of the GS2 Series AC Drives.

### Supplemental Publications

The National Electrical Manufacturers Association (NEMA) publishes many different documents that discuss standards for industrial control equipment. Global Engineering Documents handles the sale of NEMA documents. For more information, you can contact Global Engineering Documents at:

**15 Inverness Way East  
Englewood, CO 80112-5776  
1-800-854-7179 (within the U.S.)  
303-397-7956 (international)  
www.global.ihs.com**

NEMA documents that might assist with your AC drive systems are:

- **Application Guide for AC Adjustable Speed Drive Systems**
- **Safety Standards for Construction and Guide for Selection, Installation, and Operation of Adjustable Speed Drive Systems.**

### Technical Support

**By Telephone: 770-844-4200**  
(Mon.-Fri., 9:00 a.m.-6:00 p.m. E.T.)

**On the Web: [www.automationdirect.com](http://www.automationdirect.com)**

Our technical support group is glad to work with you in answering your questions. If you cannot find the solution to your particular application, or, if for any reason you need additional technical assistance, please call technical support at **770-844-4200**. We are available weekdays from 9:00 a.m. to 6:00 p.m. Eastern Time.

We also encourage you to visit our web site where you can find technical and non-technical information about our products and our company. Visit us at **[www.automationdirect.com](http://www.automationdirect.com)**.

### Special Symbols



---

*When you see the “notepad” icon in the left-hand margin, the paragraph to its immediate right will be a special note.*

---



---

**When you see the “exclamation mark” icon in the left-hand margin, the paragraph to its immediate right will be a WARNING. This information could prevent injury, loss of property, or even death (in extreme cases).**

---

# GS2 AC Drive Introduction

## Purpose of AC Drives

AC drives are generally known by many different names: Adjustable Frequency Drives (AFD), Variable Frequency Drives (VFD), and Inverters. Drives are used primarily to vary the speed of three phase AC induction motors, and they also provide non-emergency start and stop control, acceleration and deceleration, and overload protection. By gradually accelerating the motor, drives can reduce the amount of motor startup inrush current.

AC drives function by converting incoming AC power to DC, which is then synthesized back into three phase output power. The voltage and frequency of this synthesized output power is directly varied by the drive, where the frequency determines the speed of the three phase AC induction motor.

## Drive Package Contents

After receiving the AC motor drive, please check for the following:

- Make sure that the package includes an AC drive, the GS2 Series AC Drive User Manual, and the GS2 Series AC Drive Quick Reference.
- Inspect the unit to insure it was not damaged during shipment.
- Make sure that the part number indicated on the nameplate corresponds with the part number of your order.

## Model Explanation:

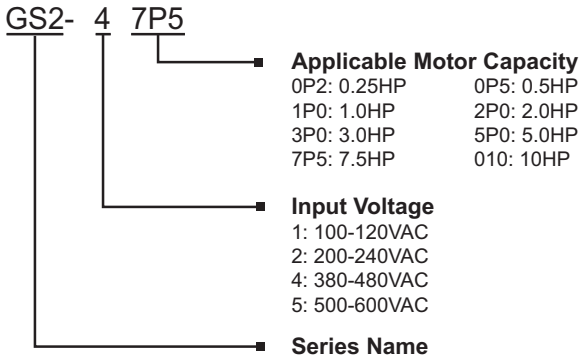

## Nameplate Information:

AC Drive Model → **MODEL: GS2-47P5**

Input Specification → INPUT: 380-480V 50/60Hz 3ph

Output Specification → OUTPUT: 0-480V 7.5hp 13Amps 9.9kVA

Output Frequency Range → FREQUENCY RANGE: 0.1-400Hz

Barcode →

Serial Number → GS2-47P5+T101001

\* 575V models are NOT CE compliant.

Automationdirect.com, Inc.

External Parts and Labels:

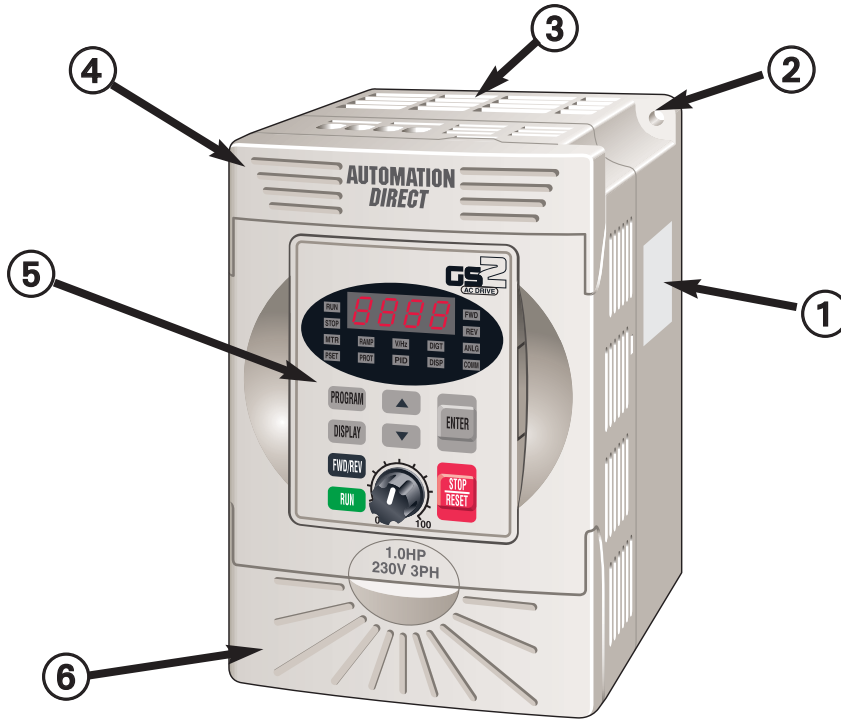

- ① Nameplate Label
- ② Mounting Screw Holes
- ③ Ventilation Slots
- ④ Upper Cover
- ⑤ Digital Keypad
- ⑥ Lower Cover
- ⑦ DIP Switches
- ⑧ Input Power Terminals
- ⑨ Control Input/Output Terminals
- ⑩ Output Power Terminals

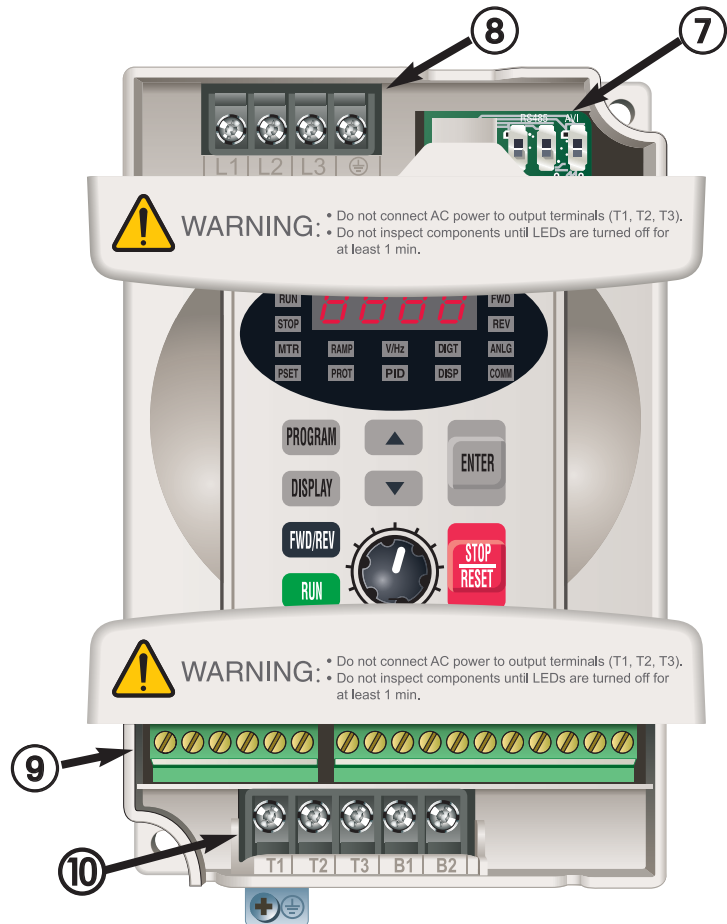

# GS2 AC Drive Specifications

| 115V Class             |  |    |   |      |      |
|------------------------|--|----|---|------|------|
| Model Name: GS2-xxx    |  |    | 10P2  | 10P5 | 11P0 |
| Output Rating          | Maximum Motor Output                         | HP | 0.25  | 0.5  | 1.0  |
|                        |  | kW | 0.2   | 0.4  | 0.75 |
|                        | Rated Output Current (A)                     |    | 1.6   | 2.5  | 4.2  |
|                        | Maximum Output Voltage                       |    | Three-phase 200 to 240V (x2 of input voltage) |      |      |
|                        | Rated Output Frequency                       |    | 0.1 to 400 Hz                                 |      |      |
| Input Rating           | Rated Voltage/Frequency                      |    | Single-phase, 100 to 120 VAC, 50/60Hz         |      |      |
|                        | Rated Input Current (A)                      |    | 6   | 9    | 16   |
|                        | Voltage/Frequency Tolerance                  |    | Voltage: +/- 10%; Frequency: +/- 5%           |      |      |
|                        | Short Circuit Withstand (A, rms symmetrical) |    | 5kA @ 120 VAC                                 |      |      |
| Watt Loss @ 100% I (W) |  |    | 24  | 34   | 46   |
| Weight (lbs.)          |  |    | 3.5   | 3.6  | 3.7  |

| 230V Class             |  |               |   |          |          |  |      |      |
|------------------------|--|---------------|---|----------|----------|--|------|------|
| Model Name: GS2-xxx    |  |               | 20P5  | 21P0     | 22P0     | 23P0   | 25P0 | 27P5 |
| Output Rating          | Maximum Motor Output                         | HP            | 0.5   | 1.0      | 2.0      | 3.0  | 5.0  | 7.5  |
|                        |  | kW            | 0.4   | 0.75     | 1.5      | 2.2  | 3.7  | 5.5  |
|                        | Rated Output Current (A)                     |               | 2.5   | 5.0      | 7.0      | 10   | 17   | 25   |
|                        | Maximum Output Voltage                       |               | Three-phase 200 to 240V (proportional to input voltage)     |          |          |  |      |      |
| Rated Output Frequency |  | 0.1 to 400 Hz |   |          |          |  |      |      |
| Input Rating           | Rated Voltage/Frequency                      |               | Single/Three-phase,<br>200/208/220/230/240 VAC,<br>50/60 Hz |          |          | Three-phase,<br>200/208/220/230/240<br>VAC, 50/60 Hz |      |      |
|                        | Rated Input Current (A)                      |               | 6.3/3.2   | 11.5/6.3 | 15.7/9.0 | 27/12.5  | 19.6 | 28   |
|                        | Voltage/Frequency Tolerance                  |               | Voltage: +/- 10%; Frequency: +/- 5%                         |          |          |  |      |      |
|                        | Short Circuit Withstand (A, rms symmetrical) |               | 5kA @ 240 VAC   |          |          |  |      |      |
| Watt Loss @ 100% I (W) |  |               | 34  | 57       | 77       | 111  | 185  | 255  |
| Weight (lbs.)          |  |               | 3.5   | 3.6      | 3.7      | 8.5  | 8.5  | 8.5  |

## GS2 AC Drive Specifications (continued)

| 460V Class             |  |               |   |      |      |      |      |      |
|------------------------|--|---------------|---|------|------|------|------|------|
| Model Name: GS2-xxx    |  |               | 41P0  | 42P0 | 43P0 | 45P0 | 47P5 | 4010 |
| Output Rating          | Maximum Motor Output                         | HP            | 1.0   | 2.0  | 3.0  | 5.0  | 7.5  | 10   |
|                        |  | kW            | 0.8   | 1.5  | 2.2  | 4.0  | 5.5  | 7.5  |
|                        | Rated Output Current (A)                     |               | 3.0   | 4.0  | 5.0  | 8.2  | 13   | 18   |
|                        | Maximum Output Voltage                       |               | Three-phase 380 to 480V (proportional to input voltage) |      |      |      |      |      |
| Rated Output Frequency |  | 0.1 to 400 Hz |   |      |      |      |      |      |
| Input Rating           | Rated Voltage/Frequency                      |               | Three-phase<br>380/400/415/440/460/480 VAC 50/60Hz      |      |      |      |      |      |
|                        | Rated Input Current (A)                      |               | 4.2   | 5.7  | 6.0  | 8.5  | 14   | 23   |
|                        | Voltage/Frequency Tolerance                  |               | Voltage: +/- 10%; Frequency: +/- 5%                     |      |      |      |      |      |
|                        | Short Circuit Withstand (A, rms symmetrical) |               | 5kA @ 480 VAC   |      |      |      |      |      |
| Watt Loss @ 100% I (W) |  |               | 73  | 86   | 102  | 170  | 240  | 255  |
| Weight (lbs.)          |  |               | 3.5   | 3.6  | 3.7  | 8.5  | 8.5  | 8.5  |

| 575V Class             |  |               |   |      |      |      |      |      |
|------------------------|--|---------------|---|------|------|------|------|------|
| Model Name: GS2-xxx    |  |               | 51P0  | 52P0 | 53P0 | 55P0 | 57P5 | 5010 |
| Output Rating          | Maximum Motor Output                         | HP            | 1.0   | 2.0  | 3.0  | 5.0  | 7.5  | 10   |
|                        |  | kW            | 0.75  | 1.5  | 2.2  | 3.7  | 5.5  | 7.5  |
|                        | Rated Output Current (A)                     |               | 1.7   | 3.0  | 4.2  | 6.6  | 9.9  | 12.2 |
|                        | Maximum Output Voltage                       |               | Three-phase 500 to 600V (proportional to input voltage) |      |      |      |      |      |
| Rated Output Frequency |  | 0.1 to 400 Hz |   |      |      |      |      |      |
| Input Rating           | Rated Voltage/Frequency                      |               | Three-phase 500 to 600V                                 |      |      |      |      |      |
|                        | Rated Input Current (A)                      |               | 2.4   | 4.2  | 5.9  | 7.0  | 10.5 | 12.9 |
|                        | Voltage/Frequency Tolerance                  |               | Voltage: -15 to +10% ; Frequency: +/- 5%                |      |      |      |      |      |
|                        | Short Circuit Withstand (A, rms symmetrical) |               | 5kA @ 600 VAC   |      |      |      |      |      |
| Watt Loss @ 100% I (W) |  |               | 30  | 58   | 83   | 132  | 191  | 211  |
| Weight (lbs.)          |  |               | 3.3   | 3.3  | 4.4  | 7.0  | 7.0  | 7.3  |

| General Specifications                |                            |  |  |
|---------------------------------------|----------------------------|--|--|
| <b>Control Characteristics</b>        |                            |  |  |
| <b>Control System</b>                 |                            | Pulse Width Modulation, Carrier frequency 1-12 kHz   |  |
| <b>Rated Output Frequency</b>         |                            | 1.0 to 400.0 Hz  |  |
| <b>Output Frequency Resolution</b>    |                            | 0.1 Hz   |  |
| <b>Overload Capacity</b>              |                            | 150% of rated current for 1 minute   |  |
| <b>Torque Characteristics</b>         |                            | Includes auto-torque boost, auto-slip compensation, starting torque 125% @ 0.5 Hz / 150% @ 5.0 Hz                                      |  |
| <b>Braking Torque</b>                 |                            | 20% without dynamic braking, 125% with optional braking resistor - braking transistor built-in   |  |
| <b>DC Braking</b>                     |                            | Operation frequency 60-0 Hz, 0 - 100% rated current, Start time 0.0 - 5.0 seconds, Stop time 0.0 - 25.0 seconds                        |  |
| <b>Acceleration/Deceleration Time</b> |                            | 0.1 to 600 seconds (linear or non-linear acceleration/deceleration), second acceleration/deceleration available                        |  |
| <b>Voltage/Frequency Pattern</b>      |                            | Settings available for Constant Torque - low & high starting torque, Variable Torque - low & high starting torque, and user configured |  |
| <b>Stall Prevention Level</b>         |                            | 20 to 200% or rated current  |  |
| <b>Operation Specification</b>        |                            |  |  |
| <b>Inputs</b>                         | <b>Frequency Setting</b>   | <b>Keypad</b>  | Setting by <UP> or <DOWN> buttons or potentiometer   |
|                                       |                            | <b>External Signal</b>   | Potentiometer - 3-5 k $\Omega$ , 0 to 10 VDC (input impedance 10 k $\Omega$ ), 0 to 20 mA / 4 to 20 mA (input impedance 250 $\Omega$ ). Multi-Speed Inputs 1 to 3, RS-232C/RS-485 communication interface  |
|                                       | <b>Operation Setting</b>   | <b>Keypad</b>  | Setting by <RUN>, <FWD/REV>, <STOP/RESET> buttons  |
|                                       |                            | <b>External Signal</b>   | Forward/Stop, Reverse/Stop (run/stop, fwd/rev), 3-wire control, Serial Communication RS-232C & RS-485 (Modbus RTU)   |
|                                       | <b>Input Terminals</b>     | <b>Digital</b>   | 6 user-programmable: FWD/STOP, REV/STOP, RUN/STOP, REV/FWD, RUN momentary (N.O.), STOP momentary (N.C.), External Fault (N.O./N.C.), External Reset, Multi-Speed Bit (1-3), Jog, External Base Block (N.O./N.C.), Second Accel/Decel Time, Speed Hold, Increase Speed, Decrease Speed, Reset Speed to Zero, PID Disable (N.O.), PID Disable (N.C.), Input Disable                |
|                                       |                            | <b>Analog</b>  | 1 user-configurable, 0 to 10 VDC (input impedance 10 k $\Omega$ ), 0 to 20 mA / 4 to 20 mA (input impedance 250 $\Omega$ ), 10 bit resolution  |
| <b>Outputs</b>                        | <b>Output Terminals</b>    | <b>Digital</b>   | 2 user-programmable: Inverter Running, Inverter Fault, At Speed, Zero Speed, Above Desired Frequency, Below Desired Frequency, At Maximum Speed, Over Torque Detected, Above Desired Current, Below Desired Current, PID Deviation Alarm   |
|                                       |                            | <b>Analog</b>  | 1 user-programmable, 0 to 10 VDC (max load 2mA), 8 bit resolution frequency, current, process variable PV  |
|                                       | <b>Operating Functions</b> |  | Automatic voltage regulation, voltage/frequency characteristics selection, non-linear acceleration/deceleration, upper and lower frequency limiters, 7-stage speed operation, adjustable carrier frequency (1 to 12 kHz), PID control, skip frequencies, analog gain & bias adjustment, jog, electronic thermal relay, automatic torque boost, trip history, software protection |

| General Specifications (continued) |   |  |
|------------------------------------|---|--|
| <b>Protective Functions</b>        | Electronic Thermal, Overload Relay, Auto Restart after Fault, Momentary Power Loss, Reverse Operation Inhibit, Auto Voltage Regulation, Over-Voltage Trip Prevention, Auto Adjustable Accel/Decel, Over-Torque Detection Mode, Over-Torque Detection Level, Over-Torque Detection Time, Over-Current Stall Prevention during Acceleration, Over-Current Stall Prevention during Operation |  |
| <b>Operator Interface</b>          | <b>Operator Devices</b>   | 8-key, 4-digit, 7-segment LED, 14 status LEDs, potentiometer   |
|                                    | <b>Programming</b>  | Parameter values for setup and review, fault codes   |
|                                    | <b>Status Display</b>   | Actual Operating Frequency, RPM, Scaled Frequency, Amps, % Load, Output Voltage, DC Bus Voltage, Process Variable, Set-point Frequency |
|                                    | <b>Key Functions</b>  | RUN, STOP/RESET, FWD/REV, PROGRAM, DISPLAY, <UP>, <DOWN>, ENTER  |
| <b>Environment</b>                 | <b>Enclosure Rating</b>   | Protected Chassis, IP20  |
|                                    | <b>Ambient Temperature</b>  | -10°C to 50°C (14°F to 122°F)<br>-10°C to 40°C (14°F to 104°F) for models 7.5 hp (5.5 kW) and higher                                   |
|                                    | <b>Storage Temperature</b>  | -20°C to 60°C (-4°F to 140°F) – during short term transportation period  |
|                                    | <b>Ambient Humidity</b>   | 20 to 90% RH (non-condensing)  |
|                                    | <b>Vibration</b>  | 9.8 m/s <sup>2</sup> (1G) less than 10 Hz, 5.9 m/s <sup>2</sup> (0.6G) 10 to 60 Hz   |
|                                    | <b>Installation Location</b>  | Altitude 1000m or lower above sea level, keep from corrosive gas, liquid and dust  |
| <b>Options</b>                     | Noise filter, input AC reactor, output AC reactor, cable for remote operator, programming software, Dynamic braking resistor, input fuses   |  |
| <b>Agency Approvals</b>            | UL & cUL listed; CE*<br>*CE certification applies only to 115V, 230V, 460V class drives.  |  |



# INSTALLATION AND WIRING

---



## In This Chapter...

|  |       |
|--|-------|
| Ambient Conditions . . . . .             | .2-2  |
| Installation . . . . .                   | .2-3  |
| Minimum Clearances and AirFlow . . . . . | .2-3  |
| Dimensions . . . . .                     | .2-4  |
| GS2 Circuit Connections . . . . .        | .2-6  |
| Danger . . . . .                         | .2-6  |
| Main Circuit Wiring . . . . .            | .2-8  |
| Control Terminal Wiring . . . . .        | .2-10 |
| Basic Wiring Diagram . . . . .           | .2-11 |
| External Accessories . . . . .           | .2-12 |

# Ambient Conditions

The AC drive should be kept in the shipping carton before installation. In order to retain the warranty coverage, the AC drive should be stored properly when it is not to be used for an extended period of time. Some storage suggestions are:

- Store in a clean and dry location free from direct sunlight or corrosive fumes.
- Store within an ambient temperature range of -20°C to +60°C.
- Store within a relative humidity range of 0% to 90% and non-condensing environment.
- Store within an air pressure range of 86 kPA to 106 kPA.

| Ambient Conditions           |  |
|------------------------------|--|
| <b>Ambient Temperature</b>   | -10°C to 50°C (14°F to 122°F) for models below 7.5 hp (5.5 kW),<br>-10°C to 40°C (14°F to 104°F) for models 7.5 hp (5.5 kW) and higher |
| <b>Storage Temperature</b>   | -20° to 60°C (-4°F to 140°F)   |
| <b>Relative Humidity</b>     | 0 to 90% (non-condensing)  |
| <b>Atmosphere Pressure</b>   | 86 kPA to 106 kPA  |
| <b>Vibration</b>             | 9.8 m/s <sup>2</sup> (1G) less than 10 Hz, 5.9 m/s <sup>2</sup> (0.6G) 10 to 60 Hz   |
| <b>Installation Location</b> | Altitude 1000m or lower above sea level, keep from corrosive gas, liquid and dust  |
| <b>Enclosure Rating</b>      | IP20: Protection against contact by fingers. Protection against medium-size foreign objects  |

## Installation



Improper installation of the AC drive will greatly reduce its life. Be sure to observe the following precautions when selecting a mounting location:

**WARNING: Failure to observe these precautions may damage the drive and void the warranty!**

- Do not mount the AC drive near heat-radiating elements or in direct sunlight.
- Do not install the AC drive in a place subjected to high temperature, high humidity, excessive vibration, corrosive gases or liquids, or airborne dust or metallic particles.
- Mount the AC drive securely on a flat, rigid, non-flammable surface.
- Mount the AC drive vertically and do not restrict the air flow to the heat sink fins.



**WARNING: AC drives generate a large amount of heat which may damage them. Auxiliary cooling methods are typically required in order not to exceed maximum ambient temperatures.**

### Minimum Clearances and Air Flow

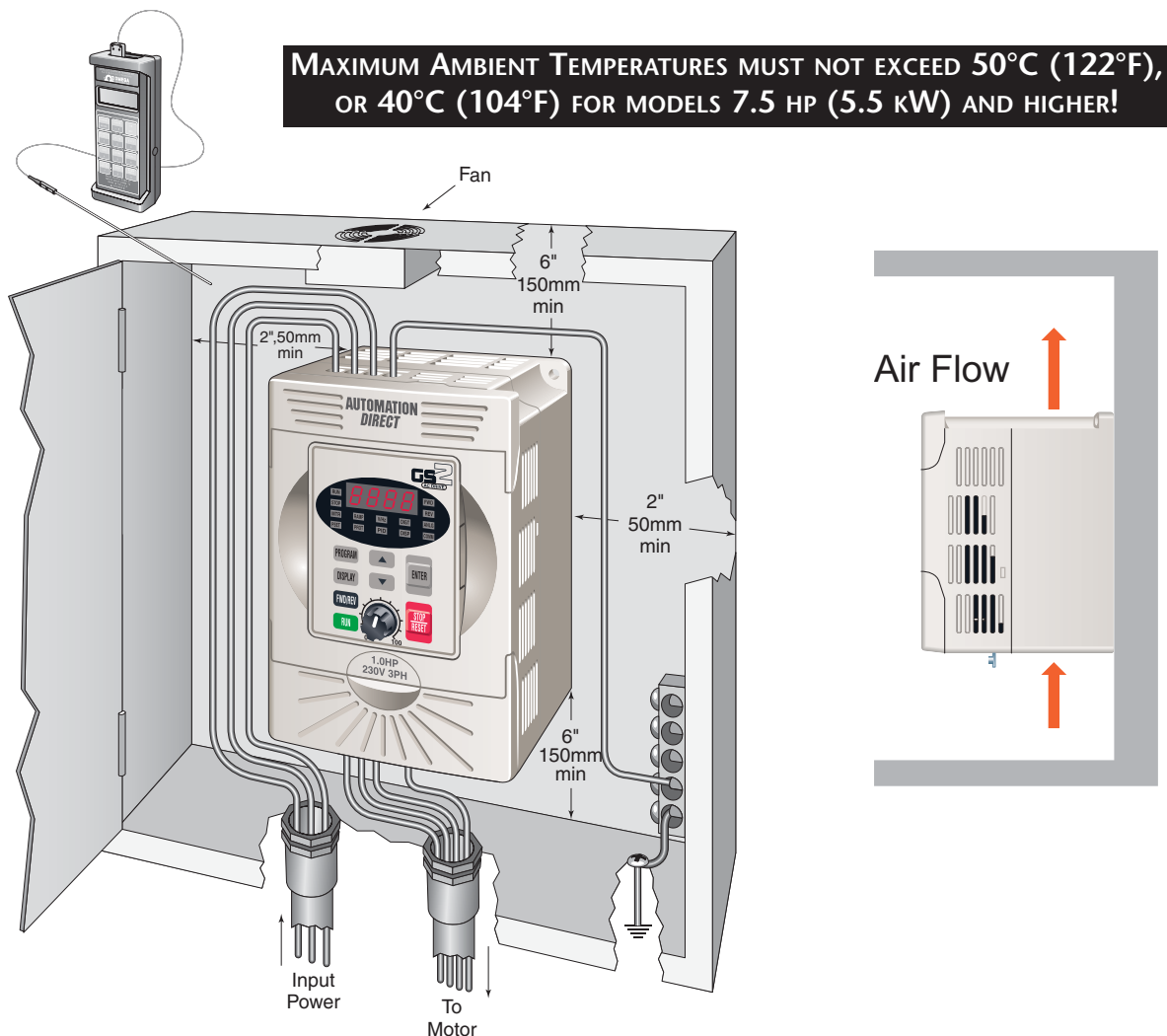

## Dimensions

GS2-10P2, GS2-10P5, GS2-11P0,  
 GS2-20P5, GS2-21P0, GS2-22P0,  
 GS2-41P0, GS2-42P0, GS2-43P0,  
 GS2-51P0, GS2-52P0, GS2-53P0

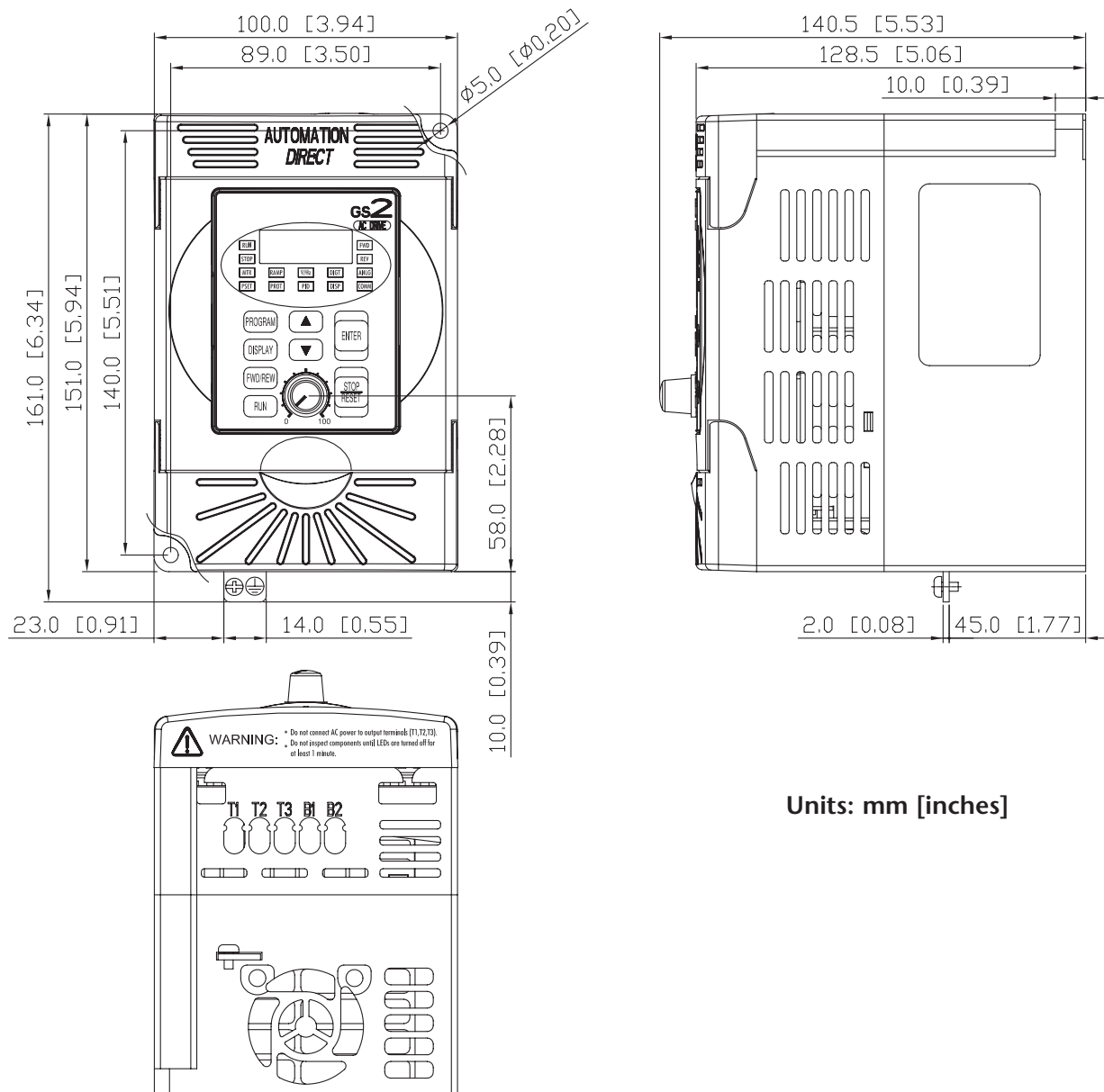

Units: mm [inches]

## Dimensions (continued)

GS2-23P0, GS2-25P0, GS2-27P5,  
GS2-45P0, GS2-47P5, GS2-4010,  
GS2-55P0, GS2-57P5, GS2-5010

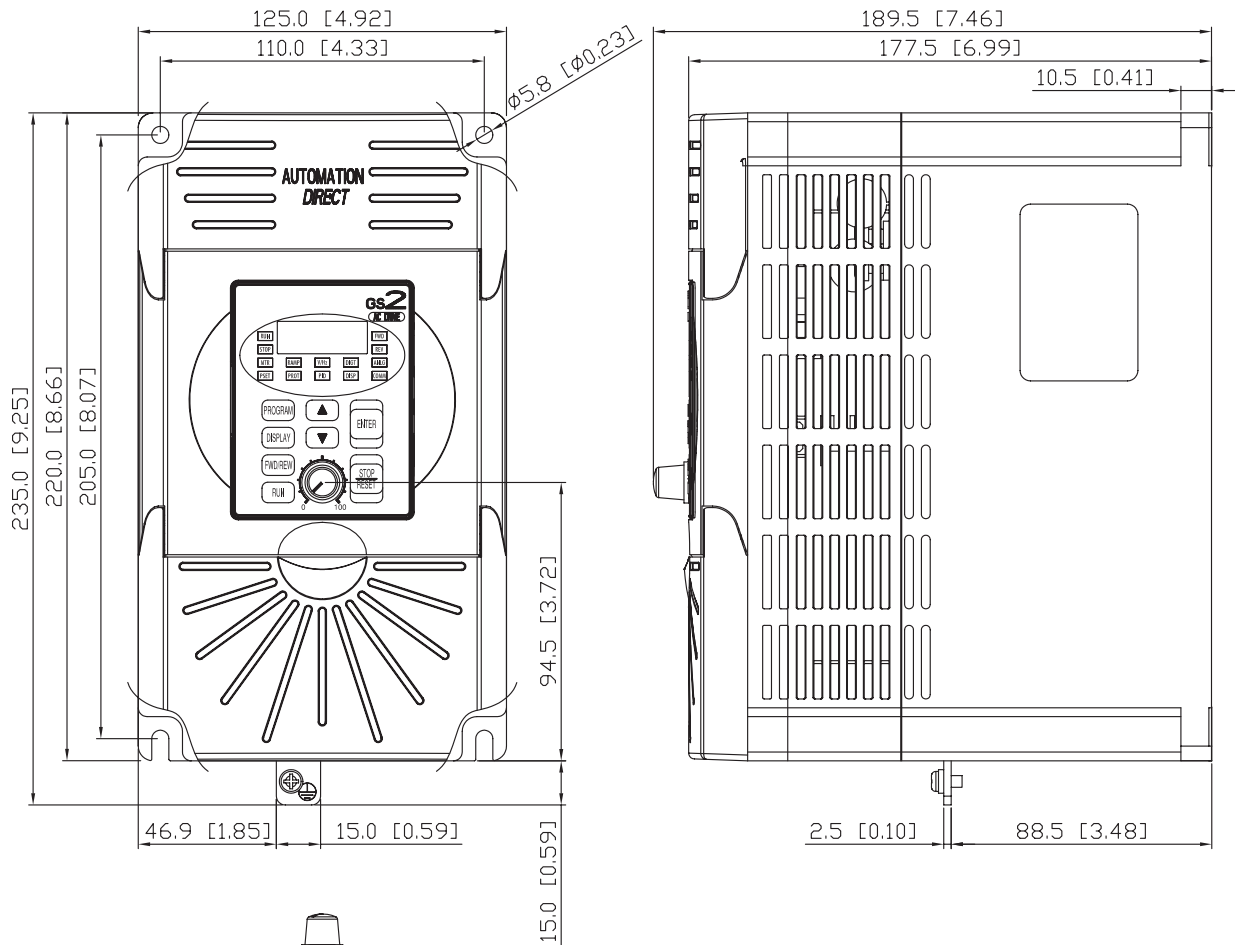

Units: mm [inches]

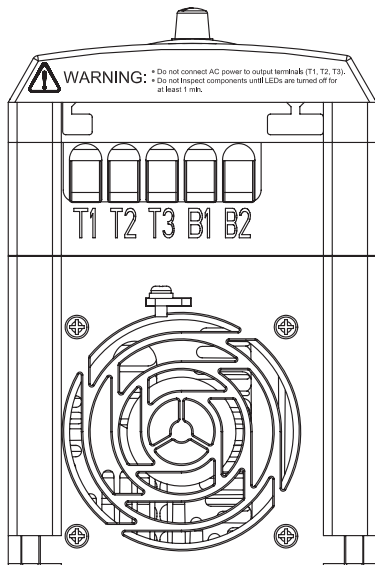

## GS2 Circuit Connections

### DANGER!



**HAZARDOUS VOLTAGE!** Before making any connection to the AC drive, disconnect all power to the AC drive, and wait five minutes for DC bus capacitors to discharge.



**Warning:** Any electrical or mechanical modification to this equipment without prior written consent of AutomationDirect.com, Inc. will void all warranties, may result in a safety hazard, and may void the UL listing.



**WARNING:** Do not connect the AC input power to the T1, T2, and T3 output terminals. This will damage the AC drive



**WARNING:** Tighten all screws to the proper torque rating. See “Main Circuit Wiring” later in this chapter.

#### Wiring Notes: PLEASE READ PRIOR TO INSTALLATION.

1. During installation, follow all local electrical, construction, and safety codes for the country in which the AC drive is to be installed.
2. Make sure the appropriate circuit protective devices (circuit breaker or fuses) are connected between the power supply and AC drive.
3. Make sure that the leads are connected correctly and the AC drive is properly grounded. (Ground resistance should not exceed  $0.1\Omega$ .)
4. Use ground leads that comply with AWG/MCM standards and keep them as short as possible.
5. Do not use a power circuit contactor or disconnect switch for run/stop control of the AC drive and motor. This will reduce the operating life cycle of the AC drive. Cycling a power circuit switching device while the AC drive is in run mode should be done only in emergency situations.
6. Multiple GS2 units can be installed in one location. All of the units should be grounded directly to a common ground terminal, or connected in parallel, as shown in the figure below. **Make sure there are no ground loops.**

Correct



Incorrect

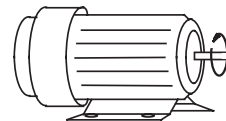

Forward  
running  
(CCW)

7. When the AC drive output terminals T1, T2, and T3 are connected to the motor terminals T1, T2, and T3, respectively, the motor will rotate counterclockwise (as viewed from the shaft end of the motor) when a forward operation command is received. To reverse the direction of motor rotation, switch the connections of any of the two motor leads.
8. Make sure that the power source is capable of supplying the correct voltage and required current to the AC drive.

9. Do not attach or remove wiring when power is applied to the AC drive.
10. Do not inspect components unless inside "POWER" lamp is turned off.
11. Do not monitor the signals on the circuit board while the AC drive is in operation.
12. For the 115V single-phase rated AC drives, AC power must be connected to input terminals L1 and L2. For the 230V single-phase rated AC drives, AC power can be connected to any two of the three input terminals L1, L2, and L3. **Note: This AC drive is not intended for use with single-phase motors.**
13. Route the power and control wires separately, or at 90 degree angle to each other.
14. If a filter is required for reducing EMI (Electro-Magnetic Interference), install it as close as possible to the AC drive. EMI can also be reduced by lowering the Carrier Frequency.
15. If the AC drive is installed in a place where a load reactor is needed, install the filter close to the T1, T2, and T3 side of AC drive. Do not use a Capacitor, L-C Filter (Inductance-Capacitance), or R-C Filter (Resistance-Capacitance), unless approved by AutomationDirect.
16. When using a GFCI (Ground Fault Circuit Interrupt), select current sensor with sensitivity of 200 mA, and not less than 0.1-second detection to avoid nuisance tripping.

### Motor Operation Precautions

1. If the AC drive is used to operate a standard 3-phase induction motor, the energy loss is greater than if using an inverter duty motor.
2. Avoid running a standard induction motor at low speed, which may cause the motor temperature to exceed the motor rating due to limited airflow produced by the motor's fan.
3. When the standard motor operates at low speed, the output load must be decreased.
4. If 100% output torque is desired at low speed, it may be necessary to use a special "inverter-duty" rated motor.

### Short Circuit Withstand Current

Suitable for use on a circuit capable of delivering not more than 5,000 rms symmetrical Amperes. The maximum voltage is 120, 240, 480, and 600V for all 115, 230, 460, and 575V models, respectively. (An optional line reactor can be installed in the incoming power circuit to reduce the available short circuit current.)

### Applicable Codes

All GS2 Series AC drives are Underwriters Laboratories, Inc. (UL) and Canadian Underwriters Laboratories (cUL) listed, and therefore comply with the requirements of the National Electrical Code (NEC) and the Canadian Electrical Code (CEC).

Installation intended to meet the UL and cUL requirements must follow the instructions provided in "Wiring Notes" as a minimum standard. Follow all local codes that exceed UL and cUL requirements. Refer to the technical data label affixed to the AC drive and the motor nameplate for electrical data.

The "Fuses and Fuse Kits" section in APPENDIX A, lists the recommended fuse part number for each GS2 Series part number. These fuses (or equivalent) must be used on all installations where compliance with U.L. standards is required.

### Main Circuit Wiring

| Main Circuit Terminals |                                     |
|------------------------|-------------------------------------|
| Terminal               | Description                         |
| L1, L2, L3             | Input Power                         |
| T1, T2, T3             | AC Drive Output                     |
| B1, B2                 | Dynamic Braking Resistor (optional) |
| ⊕                      | Ground                              |

### Output Power Connections

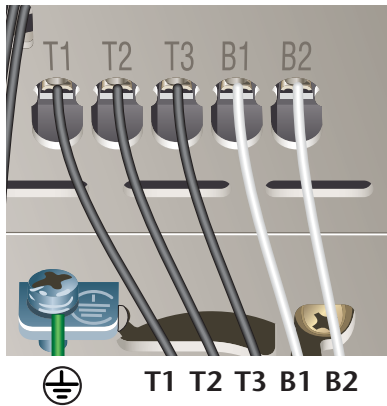

### 3-phase Input Power Connections

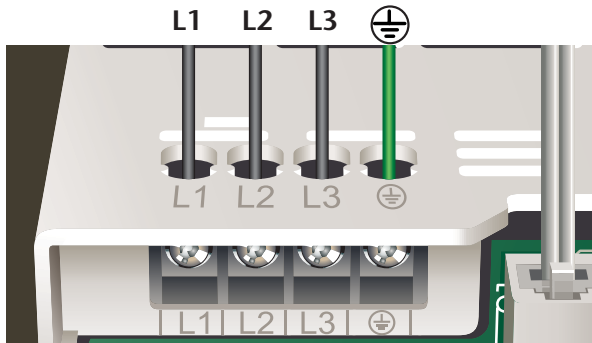

| 3-phase Input Power |                                  |
|---------------------|----------------------------------|
| <b>230V Class</b>   | 200-240V ± 10%; 50/60 Hz ± 5%    |
| <b>460V Class</b>   | 380-480V ± 10%; 50/60 Hz ± 5%    |
| <b>575V Class</b>   | 500-600V -15/+10%; 50/60 Hz ± 5% |

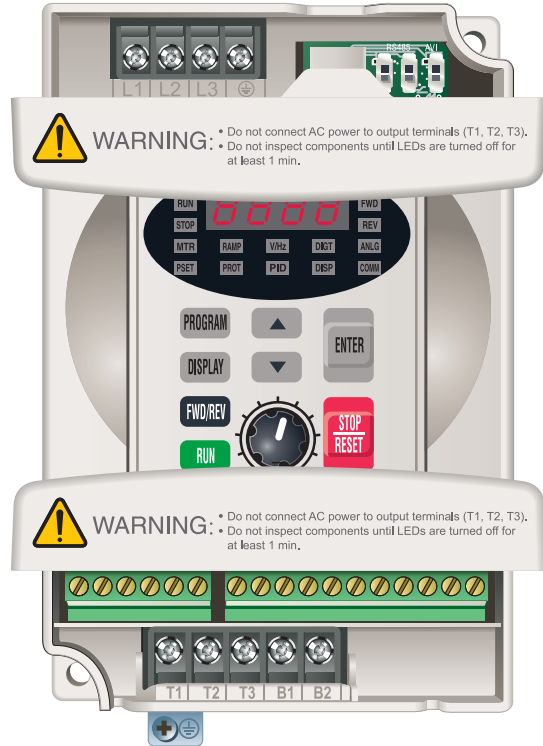

### 1-phase Input Power Connections\*

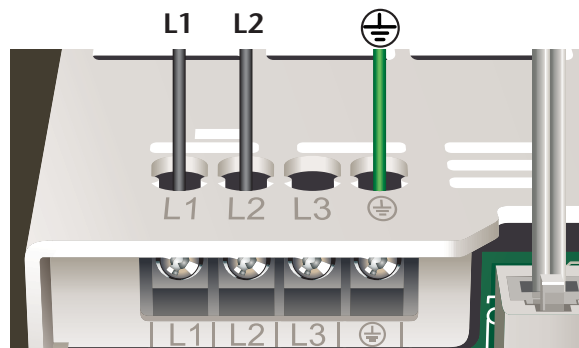

| 1-phase* Input Power   |                              |
|--|------------------------------|
| <b>115V Class</b>  | 100-120V ± 10%; 50/60Hz ± 5% |
| <b>230V Class</b>  | 200-240V ± 10%; 50/60Hz ± 5% |
| * Only models GS2-10P2, GS2-10P5, GS2-11P0, GS2-20P5, GS2-21P0, GS2-22P0, and GS2-23P0 are rated for 1-phase input power |                              |



## Main Circuit Wiring (continued)

| Main Circuit Wiring Specifications |                          |                  |                                |
|------------------------------------|--------------------------|------------------|--------------------------------|
| AC Drive Model                     | Current Input/Output (A) | Wire Gauge (AWG) | Terminal Screw Torque (in·lbf) |
| GS2-10P2 (1-phase)                 | 6 / 1.6                  | 12-14            | 12                             |
| GS2-10P5 (1-phase)                 | 9 / 2.5                  |                  |                                |
| GS2-11P0 (1-phase)                 | 16 / 4.2                 | 12               |                                |
| GS2-20P5 (1-phase)                 | 6.3 / 2.5                | 12-14            |                                |
| GS2-20P5 (3-phase)                 | 3.2 / 2.5                |                  |                                |
| GS2-21P0 (1-phase)                 | 11.5 / 5.0               |                  |                                |
| GS2-21P0 (3-phase)                 | 6.3 / 5.0                |                  |                                |
| GS2-22P0 (1-phase)                 | 15.7 / 7.0               | 12               |                                |
| GS2-22P0 (3-phase)                 | 9 / 7.0                  | 12-14            |                                |
| GS2-23P0 (1-phase)                 | 27 / 10                  | 8                |                                |
| GS2-23P0 (3-phase)                 | 12.5 / 10                | 8-12             |                                |
| GS2-25P0                           | 19.6 / 17                | 8-10             |                                |
| GS2-27P5                           | 28 / 25                  | 8                |                                |
| GS2-41P0                           | 4.2 / 3.0                | 12-14            | 12                             |
| GS2-42P0                           | 5.7 / 4.0                |                  |                                |
| GS2-43P0                           | 6.0 / 5.0                |                  |                                |
| GS2-45P0                           | 8.5 / 8.2                | 8-14             | 13                             |
| GS2-47P5                           | 14 / 13                  | 8-12             |                                |
| GS2-4010                           | 23 / 18                  | 8-10             |                                |
| GS2-51P0                           | 2.4 / 1.7                | 12-14            | 12                             |
| GS2-52P0                           | 4.2 / 3.0                |                  |                                |
| GS2-53P0                           | 5.9 / 4.2                |                  |                                |
| GS2-55P0                           | 7.0 / 6.6                | 8-14             | 13                             |
| GS2-57P5                           | 10.5 / 9.9               |                  |                                |
| GS2-5010                           | 12.9 / 12.2              |                  |                                |

NOTE: Use 75°C (or higher) copper wire only.

### Control Terminal Wiring

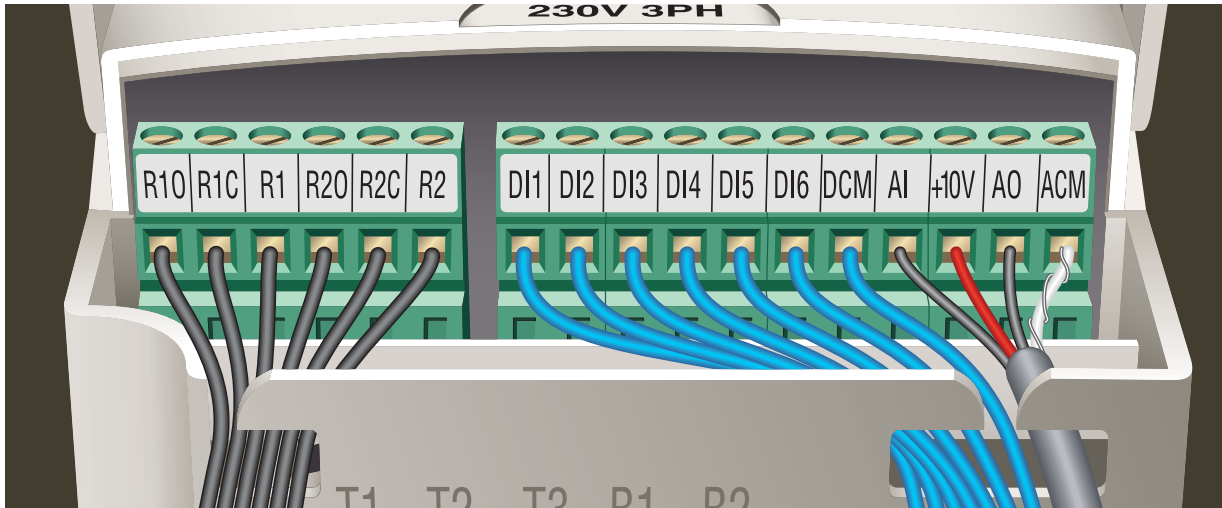

| Control Circuit Terminals |                                |  |
|---------------------------|--------------------------------|--|
| Terminal Symbol           | Description                    | Remarks  |
| R10                       | Relay Output 1 Normally Open   | 120 VAC / 24 VDC @ 5A<br>230 VAC @ 2.5A  |
| R1C                       | Relay Output 1 Normally Closed |  |
| R1                        | Relay Output 1 Common          |  |
| R20                       | Relay Output 2 Normally Open   |  |
| R2C                       | Relay Output 2 Normally Closed |  |
| R2                        | Relay Output 2 Common          |  |
| DI1                       | Digital Input 1                | Input Voltage: Internally Supplied ( <i>see WARNING below</i> )<br>Input Voltage Range: 4-12V<br>Minimum ON Current: 22 mA max<br>Maximum OFF Current: 1.1 mA<br>also see "Basic Wiring Diagram" on next page. |
| DI2                       | Digital Input 2                |  |
| DI3                       | Digital Input 3                |  |
| DI4                       | Digital Input 4                |  |
| DI5                       | Digital Input 5                |  |
| DI6                       | Digital Input 6                |  |
| DCM                       | Digital Common                 |  |
| AI                        | Analog Input                   | 0 to +10V Input<br>0 to 20 mA Input, or<br>4 to 20 mA Input  |
| +10V                      | Internal Power Supply          | +10 VDC (10 mA maximum load)   |
| AO                        | Analog Output                  | 0 to +10V Output (2mA maximum load)  |
| ACM                       | Analog Common                  |  |



**Warning:** Do NOT connect external voltage sources to the Digital Inputs. Permanent damage may result.



*Note:* Use twisted-shielded, twisted-pair, or shielded-lead wires for the control signal wiring. It is recommended to run all signal wiring in a separate steel conduit. The shield wire should be connected only at the AC drive. Do not connect shield wire on both ends.

## Basic Wiring Diagram



Note: Users must connect wiring according to the circuit diagram shown below.

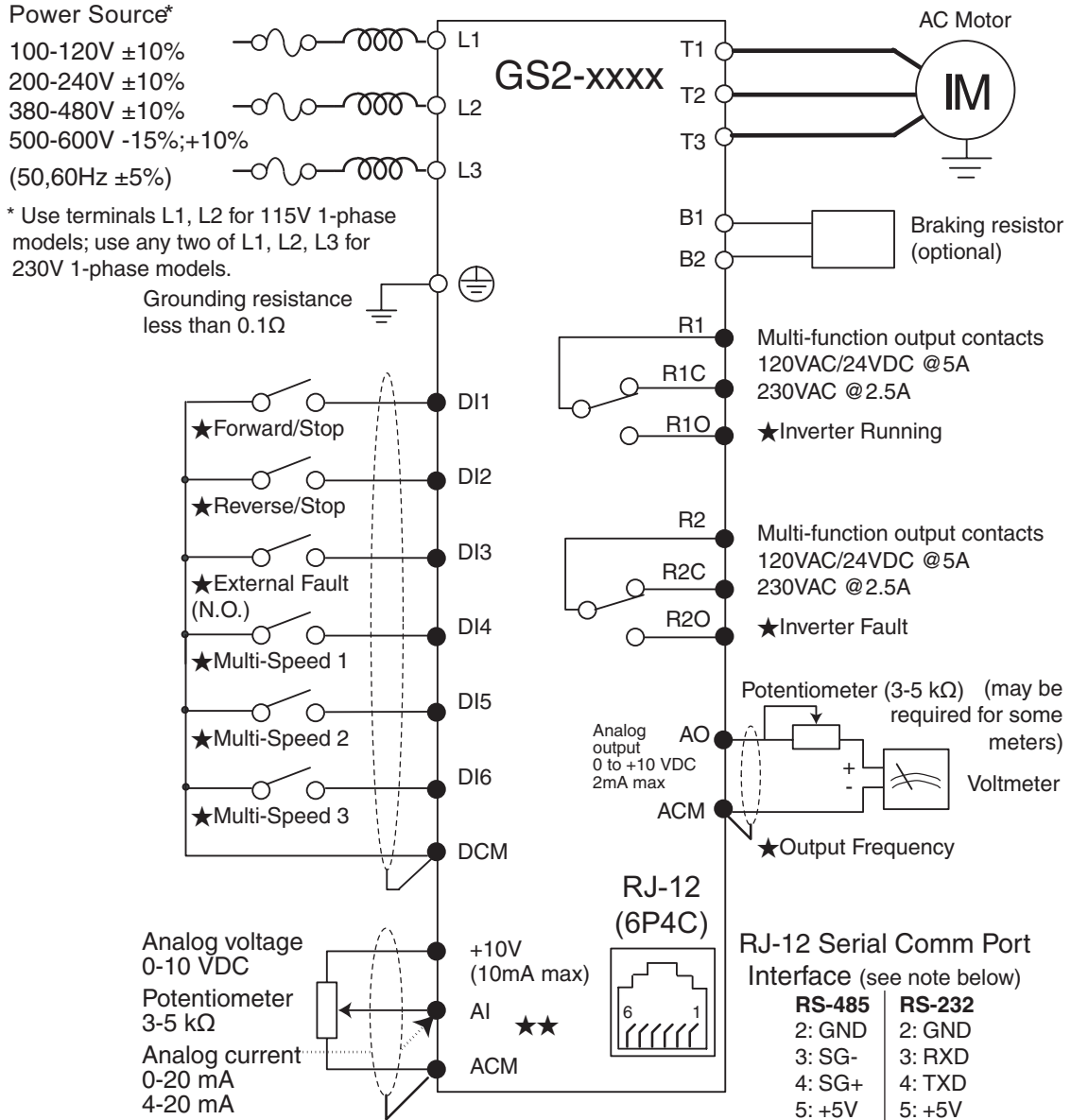

★ Factory default setting

★★ Factory default source of frequency command is via the keypad potentiometer

○ Main circuit (power) terminals   ● Control circuit terminal   ⊕ Shielded leads



**WARNING: Do not plug a modem or telephone into the GS2 RJ-12 Serial Comm Port, or permanent damage may result. Terminals 2 and 5 should not be used as a power source for your communication connection.**

## External Accessories

Refer to Appendix A for information regarding external accessories.

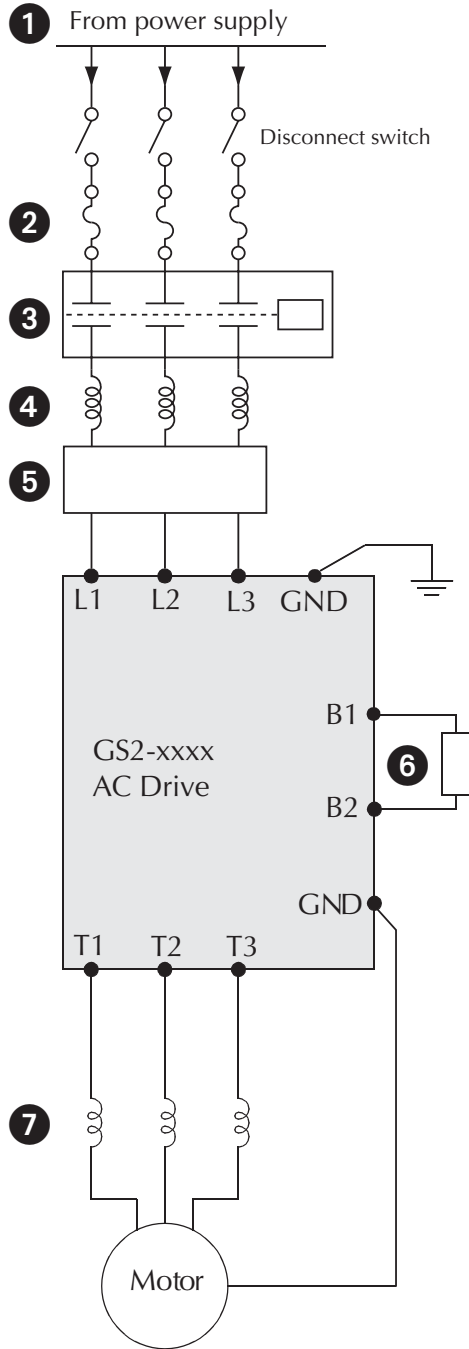

### 1 Power Supply

Please follow the specific power supply requirements shown in CHAPTER 1

### 2 Fuses

Input fuses protect the AC drive from excessive input current due to line surges, short circuits, and ground faults. They are recommended for all installations and may be required for UL-listed installations.

### 3 Contactor (Optional)

Do not use a contactor or disconnect switch for run/stop control of the AC drive and motor. This will reduce the operating life cycle of the AC drive. Cycling a power circuit switching device while the AC drive is in run mode should be done only in emergency situations.

### 4 AC Line Reactor (Optional)

Input line reactors protect the AC drive from transient overvoltage conditions typically caused by utility capacitor switching. Input line reactors also reduce the harmonics associated with AC drives, and are recommended for all installations.

### 5 EMI filter (Optional)

Input EMI filters reduce electromagnetic interference or noise on the input side of the AC drive. They are required for CE compliance and recommended for installations prone to or sensitive to electromagnetic interference.

### 6 Braking Resistors (Optional)

Dynamic braking allows the AC drive to produce additional braking (stopping) torque. AC drives can typically produce between 15% & 20% braking torque without the addition of any external components. The addition of optional braking may be required for applications that require rapid deceleration or high inertia loads.

### 7 AC Line Reactor (Optional)

Output line (load) reactors protect the motor insulation against AC drive short circuits and IGBT reflective wave damage, and also allow the motor to run cooler by smoothing the motor current waveform. They are recommended for operating "non-inverter-duty" motors, and for any motors when the length of wiring between the AC drive and motor exceeds 75 feet.



*Note: Please refer to Appendix A for specifications on GS2 AC Drive Accessories.*

# KEYPAD OPERATION AND QUICKSTART

---



## In This Chapter...

|   |      |
|---|------|
| The GS2 Digital Keypad . . . . .                                | 3-2  |
| LED Display . . . . .   | 3-2  |
| LED Indicators . . . . .  | 3-2  |
| Function Keys . . . . .   | 3-3  |
| Displaying the Status of the GS2 AC Drive . . . . .             | 3-4  |
| Programming the GS2 AC Drive . . . . .                          | 3-5  |
| GS2 Quickstart . . . . .  | 3-6  |
| Example 1: Constant torque (e.g. conveyors, compressors, etc.)  | 3-6  |
| Example 2: Variable torque (e.g. fans, centrifugal pumps, etc.) | 3-11 |

## The GS2 Digital Keypad

The digital keypad includes a 4-digit LED display, 14 LED Indicators, 8 function keys, and a potentiometer. The diagram below shows all of the features of the digital keypad and an overview of their functions.

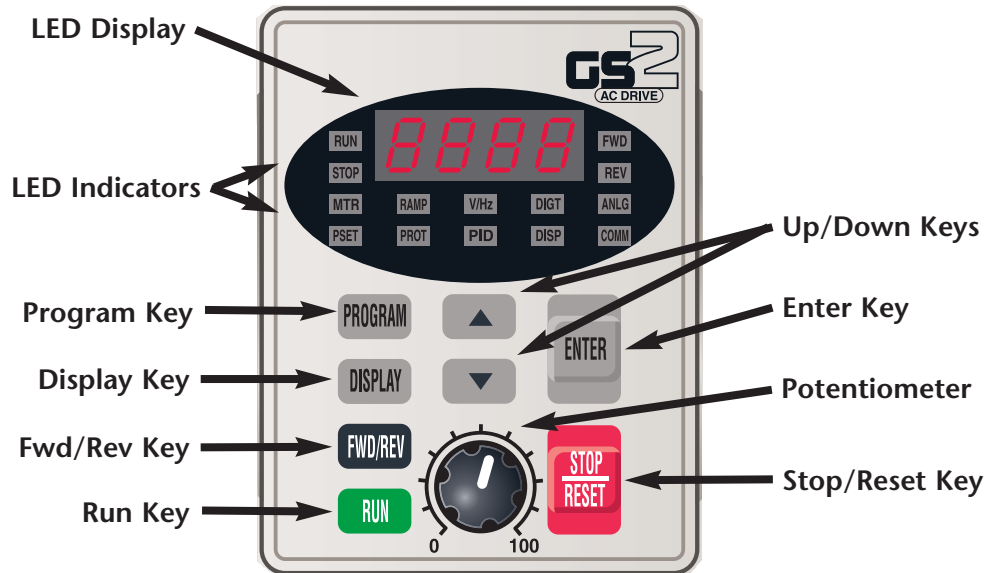





### LED Display

The LED display shows the AC drive operation values and parameter settings.

### LED Indicators

- RUN** The RUN LED indicates the AC drive is in Run Mode. The RUN LED blinks when the drive is decelerating to stop.
- STOP** The STOP LED indicates the AC drive is not in Run Mode. The STOP LED blinks when the drive is in Run Mode, but has zero speed reference.
- FWD** The FWD LED indicates the AC drive is running the motor in the forward direction.
- REV** The REV LED indicates the AC drive is running the motor in the reverse direction.
- MTR** The MTR LED indicates the AC drive is in Program Mode and is displaying the Motor Parameters group (P 0.xx).
- RAMP** The RAMP LED indicates the AC drive is in Program Mode and is displaying the Ramp Parameters group (P 1.xx).
- V/Hz** The V/Hz LED indicates the AC drive is in Program Mode and displays the Volts/Hertz Parameters group (P 2.xx).
- DIGT** The DIGT LED indicates the AC drive is in Program Mode and displays the Digital Parameters group (P 3.xx).
- ANLG** The ANLG LED indicates the AC drive is in Program Mode and displays the Analog Parameters group (P 4.xx).

-  The **PSET** LED indicates the AC drive is in Program Mode and displays the Preset Parameters group (P 5.xx).
-  The **PROT** LED indicates the AC drive is in Program Mode and displays the Protection Parameters group (P 6.xx).
-  The **PID** LED indicates the AC drive is in Program Mode and displays the PID Parameters group (P 7.xx).
-  The **DISP** LED indicates the AC drive is in Program Mode and displays the Display Parameters group (P 8.xx).
-  The **COMM** LED indicates the AC drive is in Program Mode and displays the Communication Parameters group (P 9.xx).

### Function Keys

 Pressing the **PROGRAM** key repetitively cycles through the parameter groups. As you cycle through the parameter groups, an LED indicator lights to show you which parameter group is selected.

 Pressing the **DISPLAY** key cycles through the operational values of the AC drive when the AC drive is not in Program Mode. When in Program Mode, the Display key will display the value of the selected parameter.

 Pressing the **FWD/REV** key changes the direction in which the motor operates.

 Pressing the **RUN** key starts the AC drive operation. This key has no function if the AC drive is controlled by the external control terminals.

 Press the **UP/DOWN** arrow keys momentarily to change parameter settings. These keys may also be used to scroll through different operating values or parameters. Pressing the "Up" or "Down" key momentarily, changes the parameter settings in single-unit increments. To quickly run through the range of settings, press and hold the "Up" or "Down" key.

 Press the **ENTER** key to view parameters and store parameter settings.

 The **STOP/RESET** key is used to stop AC drive operation. If the AC drive has stopped due to a fault, clear the fault first, then press this key to reset the AC drive.



The **POTENTIOMETER** is for setting operation frequency.

### Displaying the Status of the GS2 AC Drive

Press the display button on the keypad repeatedly to cycle through the status messages on the AC drive. The diagram below shows the order of the status messages as you cycle through them, and shows the definitions of the status messages. The status of the AC drive can be shown in RUN or STOP mode.

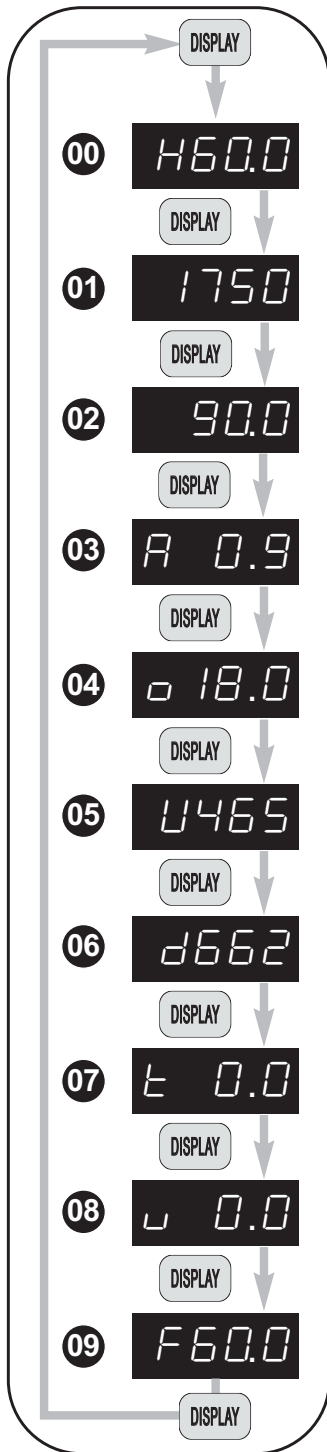

- 00 Actual Operating Frequency**  
Displays the actual operating frequency present at the T1, T2, and T3 terminals. *Example: 60.0Hz*
  - 01 RPM**  
Displays the present *estimated* speed of the motor. *Example: 1750 rpm*
  - 02 Scaled Frequency**  
Displays the result of output frequency x P 8.01. *Example: 60Hz x 1.5 = 90.0*
  - 03 Amps**  
Displays the output current present at the T1, T2, and T3 terminals. *Example: 0.9A*
  - 04 % Load**  
Displays the amount of load on the AC drive. *Example: (Output Current ÷ Drive Rated Current) x 100*
  - 05 Output Voltage**  
Displays the output voltage present at the T1, T2, and T3 terminals. *Example: 465V*
  - 06 DC Bus Voltage**  
Displays the DC Bus Voltage. *Example: 662 VDC*
  - 07 PID Setpoint**  
Displays the PID setpoint. *Note: It is possible to change the PID setpoint with the ▲ and ▼ keys when the PID setpoint value is displayed on the keypad. The PID function (P 7.00) must be enabled, and the PID Setpoint source (P 7.02) must be set to keypad (00).*
  - 08 PID Feedback Signal (PV)**  
Displays the PID feed-back signal.
- \ | / NOTE:  
PID The LED will flash when the  
 / | \ **PID Setpoint** or **Process Variable** is displayed.
- 09 Setpoint Frequency**  
Displays the frequency setting of the AC drive. *Example: 60.0 Hz*



## Programming the GS2 AC Drive

The GS2 AC Drive parameters are organized into 10 different groups according to their functions. The illustration below shows you how to navigate through the parameter groups and parameter settings. For a complete list of parameters, refer to CHAPTER 4.

- 1 Press the "Program" key repetitively to cycle through the parameter groups. As you cycle through the parameter groups, an LED indicator will light to show you which parameter group is selected.
- 2 Once you reach the desired parameter group, use the UP/DOWN keys to cycle through the available parameters in that group.

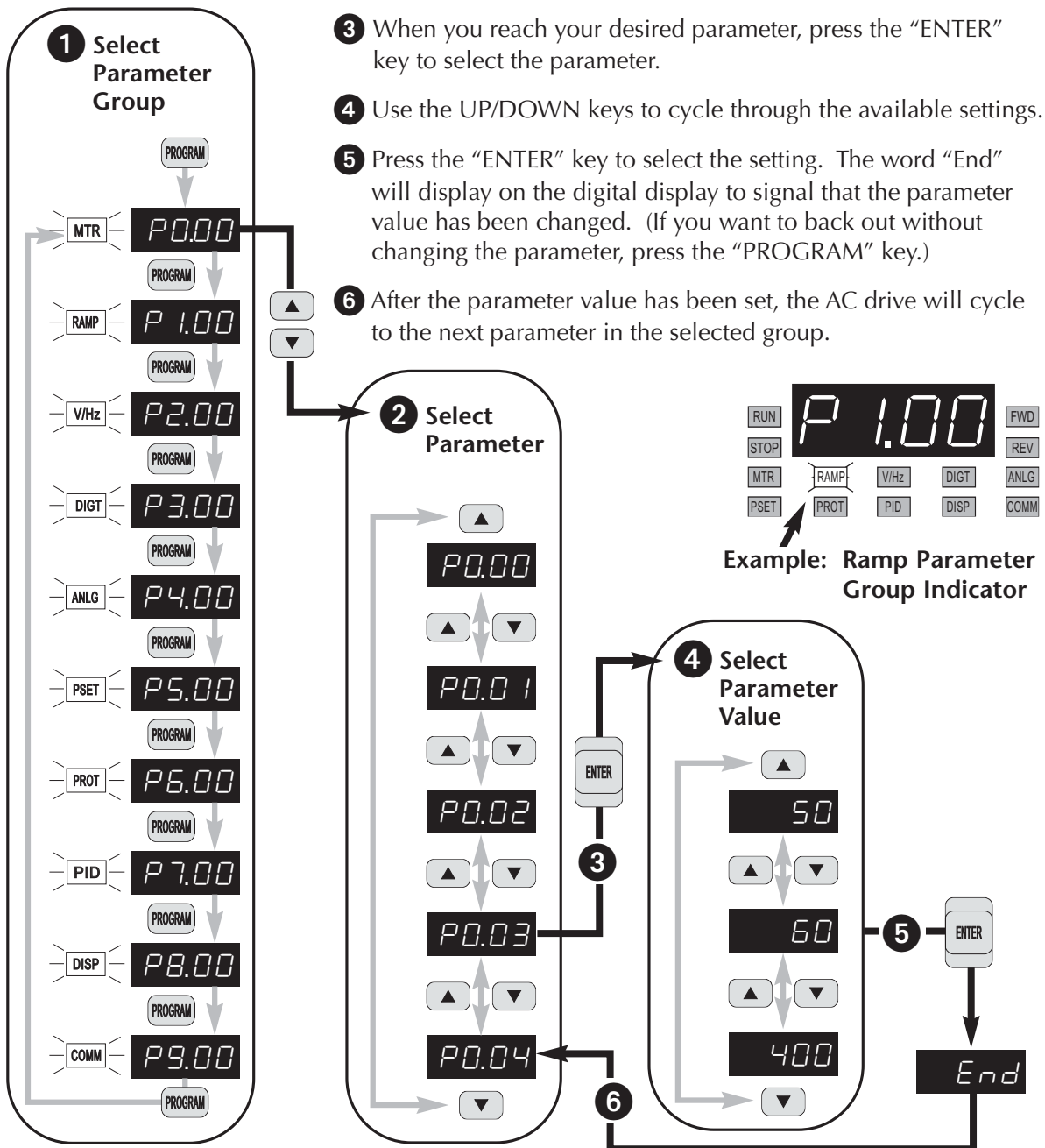

- 3 When you reach your desired parameter, press the "ENTER" key to select the parameter.
- 4 Use the UP/DOWN keys to cycle through the available settings.
- 5 Press the "ENTER" key to select the setting. The word "End" will display on the digital display to signal that the parameter value has been changed. (If you want to back out without changing the parameter, press the "PROGRAM" key.)
- 6 After the parameter value has been set, the AC drive will cycle to the next parameter in the selected group.

## GS2 Quickstart

The following examples will help you quickly set up your GS2 AC Drive for two common applications. The first example applies to an application that requires constant torque, and the second example requires variable torque.



*Note: For a complete list and description of the parameters for the GS2 Series AC drives, refer to CHAPTER 4.*

### Example 1: Constant torque (e.g. conveyors, compressors, etc.)

In this example, the AC drive needs to operate a motor that is connected to a conveyor. In order to decide which parameters need modifications, we will make a list of the needs for the application.

#### Application Needs

- The AC drive must control a 460V, 1hp inverter duty motor. We will use a model GS2-41P0 drive for this application. An example of the motor nameplate is shown below.

| INVERTER DUTY MOTOR |      |       |      |             |    |      |      |
|---------------------|------|-------|------|-------------|----|------|------|
| HP                  | 1    | Volts | 460  | PHASE       | 3  | TYPE | P    |
| RPM                 | 1725 | AMPS  | 2.6  | HZ          | 60 | SF   | 1.15 |
| DESIGN              | B    | AMB   | 40°C | INSUL CLASS | F  |      |      |
| DUTY                | CONT | ENCL  | TEFC | CODE        | K  |      |      |

- The maximum speed for the motor is 2000 rpm.
- The motor should accelerate to maximum speed in 5 seconds.
- The motor should decelerate from maximum speed in 5 seconds.
- The motor will require a high torque when starting.
- The operation of the motor (start, stop, etc.) will be controlled by remote control terminals. All keys on the GS2 keypad should be disabled.
- The frequency of the AC drive will be determined by remote potentiometer that has a 0 to +10V signal.
- The display of the AC drive should default to the motor speed (rpm) when running.

### Parameter Setup

In order to meet the needs of this application, the drive parameters should be set as follows:

**P 0.00**      **Motor Nameplate Voltage**      **Setting: 460**

Range: 115V&230V class: 200/208/220/230/240      Default Setting: 240  
 460V class: 380/400/415/440/460/480      480  
 575V class: 380 to 637      575

This parameter setting is determined by the motor nameplate.

**P 0.01**      **Motor Nameplate Amps**      **Setting: 2.6**

Range: Drive Rated Amps x .3 to      Default Setting: Drive Rating (A)  
 Drive Rated Amps x 1.0

This parameter setting is determined by the motor nameplate..

**P 0.02**      **Motor Base Frequency**      **Setting: 60**

Range: 50/60/400      Default Setting 60

This parameter setting is determined by the motor nameplate.

**P 0.03**      **Motor Base RPM**      **Setting: 1725**

Range: 375 to 9999 rpm      Default Setting: 1750

This parameter setting is determined by the motor nameplate.

**P 0.04**      **Motor Maximum RPM**      **Setting: 2000**

Range: P 0.03 to 9999 rpm      Default Setting: P 0.03

This parameter setting is determined by the needs of the application.



**WARNING: The Motor Maximum RPM parameter (P 0.04) should never exceed the maximum rpm rating for the motor you are using. If this information is not readily available, consult your motor manufacturer.**

### **P 1.00** Stop Methods **Setting: 00**

Range: 00 Ramp to Stop Default Setting: 00  
01 Coast to stop

The Ramp to Stop setting causes the drive to stop the motor under power according to the Deceleration Time set in P 1.02. If the AC drive was set for Coast to Stop, the AC drive would ignore the Deceleration Time setting.



---

**WARNING:** If the Stop Method for the GS2 AC drive is set for Coast to Stop, the AC drive will ignore any setting you have for Deceleration Time (P 1.02).

---

### **P 1.01** Acceleration Time **Setting: 5.0**

Range: 0.1 to 600 sec Default Setting: 10 sec

The motor should accelerate from 0 rpm to base rpm (P 0.03) in 5 seconds.

### **P 1.02** Deceleration Time **Setting: 5.0**

Range: 0.1 to 600 sec Default Setting: 30 sec

The motor should decelerate from 2000 rpm (maximum speed) to 0 rpm in 5 seconds.

### **P 2.00** Volts/Hertz Settings **Setting: 01**

Settings: 00 - General Purpose Default Setting: 0.0  
01 - High Starting Torque  
02 - Fans and Pumps  
03 - Custom

The GS2 Series AC drive has some predefined torque settings that meet the needs of most applications. A custom setting is available if needed. In this example, the application requires a high starting torque.

**P 3.00** **Source of Operation Command** **Setting: 02**

Default Setting: 00

- |          |    |  |
|----------|----|--|
| Settings | 00 | Operation Determined by Digital Keypad                                       |
|          | 01 | Operation determined by external control terminals. Keypad STOP is enabled.  |
|          | 02 | Operation determined by external control terminals. Keypad STOP is disabled. |
|          | 03 | Operation determined by RS-232/RS-485 interface. Keypad STOP is enabled.     |
|          | 04 | Operation determined by RS-232/RS-485 interface. Keypad STOP is disabled.    |

The AC drive operation will be determined by external control terminals and the keypad stop will be disabled.

**P 4.00** **Source of Frequency Command** **Setting: 02**

Default: 00

- |           |    |   |
|-----------|----|---|
| Settings: | 00 | Frequency determined by keypad potentiometer  |
|           | 01 | Frequency determined by digital keypad up/down  |
|           | 02 | Frequency determined by 0 to +10V input on AI terminal. Switch, SW1 must be set to AVI.   |
|           | 03 | Frequency determined by 4 to 20mA input on AI terminal. Switch SW1 must be set to ACI.  |
|           | 04 | Frequency determined by 0 to 20mA input on AI terminal. Switch SW1 must be set to ACI.  |
|           | 05 | Frequency determined by RS-232/RS-485 communication interface ( <i>RS-232 or RS-485 communication selected by switches SW2 and SW3. Refer to CHAPTER 5 for details.</i> ) |



← **Switch SW1 must be set to AVI in order to use a 0 to +10V input**



← **Switch SW1 must be set to ACI in order to use a 4 to 20mA input**



← **Switch SW1 must be set to ACI in order to use a 0 to 20mA input**

The frequency of the AC drive will be determined by an external potentiometer with a 0 to +10V signal.

### **P 6.00**

### **Electronic Thermal Overload Relay**

**Setting: 00**

Default Setting: 00

Settings: 00 - Constant Torque (inverter/vector duty motor)  
01 - Variable Torque (fan-cooled standard motor)  
02 - Inactive

This function setting 00 is the standard overload protection curve used to protect inverter/vector duty motors.

### **P 8.00**

### **User Defined Display Function**

**Setting: 01**

Default Setting: 00

Settings:

|    |                           |
|----|---------------------------|
| 00 | Output Frequency (Hz)     |
| 01 | Motor Speed (rpm)         |
| 02 | Output Frequency x P 8.01 |
| 03 | Output Current (A)        |
| 04 | Motor Output Current (%)  |
| 05 | Output Voltage(V)         |
| 06 | DC Bus Voltage (V)        |
| 07 | PID Setpoint              |
| 08 | PID Feedback (PV)         |
| 09 | Frequency Setpoint        |

The AC drive display will default to motor speed (rpm) when running.

**Example 2: Variable torque (e.g. fans, centrifugal pumps, etc.)**

In this example, the AC drive needs to operate a motor that is connected to a centrifugal pump. As in Example 1, we will make a list of the needs for the application in order to decide which parameters need modifications.

**Application Needs**

- The AC drive must control a 208V, 3hp fan-cooled standard duty motor. The AC drive model we will be using for this application is a GS2-23P0. An example of the motor nameplate is shown below.

| STANDARD DUTY MOTOR |      |       |      |             |    |
|---------------------|------|-------|------|-------------|----|
| HP                  | 3    | Volts | 208  | PHASE       | 3  |
| RPM                 | 3525 | AMPS  | 9.2  | HZ          | 60 |
| DESIGN              | B    | AMB   | 40°C | INSUL CLASS | F  |
| DUTY                | CONT | ENCL  | TEFC | CODE        | K  |

- The maximum speed for the motor is 3600 rpm.
- The motor should accelerate to maximum speed in 20 seconds.
- The motor should coast to stop when operation is terminated.
- The motor will be turning a centrifugal pump.
- The operation of the motor (start, stop, etc.) will be controlled by the GS2 digital keypad.
- The frequency of the AC drive will be determined by the GS2 keypad potentiometer.
- The display of the AC drive should default to output current (A) when running.

**Parameter Setup**

In order to meet the needs of this application, the parameters should be set as follows:

**P 0.00 Motor Nameplate Voltage Setting: 208**

Range: 115V&230V class: 200/208/220/230/240 Default Setting: 240  
 460V class: 380/400/415/440/460/480 480  
 575V class: 380 to 637 575

This parameter setting is determined by the motor nameplate.

**P 0.01 Motor Nameplate Amps Setting: 9.2**

Range: Drive Rated Amps x .3 to Drive Rated Amps x 1.0 Default Setting: Drive Rating (A)

This parameter setting is determined by the motor nameplate.

**P 0.02**      **Motor Base Frequency**      **Setting: 60**

Range: 50/60/400      Default Setting: 60

This parameter setting is determined by the motor nameplate.

**P 0.03**      **Motor Base RPM**      **Setting: 3525**

Range: 375 to 9999 rpm      Default Setting: 1750

This parameter setting is determined by the motor nameplate.

**P 0.04**      **Motor Maximum RPM**      **Setting: 3600**

Range: P 0.03 to 9999 rpm      Default Setting: P 0.03

This parameter setting is determined by the needs of the application.



---

**WARNING: The Motor Maximum RPM parameter (P 0.04) should never exceed the maximum rpm rating for the motor you are using. If this information is not readily available, consult your motor manufacturer.**

---

**P 1.00**      **Stop Methods**      **Setting: 01**

Range: 00 Ramp to Stop      Default Setting: 00  
          01 Coast to stop

The application requires that this parameter be set to Coast to Stop.



---

**WARNING: If the Stop Method for the GS2 AC drive is set for Coast to Stop, the AC drive will ignore any setting you have for Deceleration Time (P 1.02).**

---

**P 1.01**      **Acceleration Time**      **Setting: 20.0**

Range: 0.1 to 600 sec      Default Setting: 10 sec

The motor should accelerate from 0 rpm to Base rpm (P 0.03) in 20 seconds.

**P 2.00**      **Volts/Hertz Settings**      **Setting: 02**

Range: 00 - General Purpose      Default Setting: 0.0  
          01 - High Starting Torque  
          02 - Fans and Pumps  
          03 - Custom

The GS2 Series AC drive has predefined torque settings that meet the needs of most applications. A custom setting is also available, if needed. In this example, the motor will be running a centrifugal pump.



**P 3.00** **Source of Operation Command** **Setting: 00**



Default Setting: 00

- |          |    |  |
|----------|----|--|
| Settings | 00 | Operation Determined by Digital Keypad                                       |
|          | 01 | Operation determined by external control terminals. Keypad STOP is enabled.  |
|          | 02 | Operation determined by external control terminals. Keypad STOP is disabled. |
|          | 03 | Operation determined by RS-232/RS-485 interface. Keypad STOP is enabled.     |
|          | 04 | Operation determined by RS-232/RS-485 interface. Keypad STOP is disabled.    |

The AC drive operation will be determined by the Digital Keypad.

**P 4.00** **Source of Frequency Command** **Setting: 00**

Default: 00

- |           |    |   |
|-----------|----|---|
| Settings: | 00 | Frequency determined by keypad potentiometer  |
|           | 01 | Frequency determined by digital keypad up/down  |
|           | 02 | Frequency determined by 0 to +10V input on AI terminal. Switch, SW1 must be set to AVI.   |
|           |    |  <b>Switch SW1 must be set to AVI in order to use a 0 to +10V input</b>                |
|           | 03 | Frequency determined by 4 to 20mA input on AI terminal. Switch SW1 must be set to ACI.  |
|           |    |  <b>Switch SW1 must be set to ACI in order to use a 4 to 20mA input</b>                |
|           | 04 | Frequency determined by 0 to 20mA input on AI terminal. Switch SW1 must be set to ACI.  |
|           |    |  <b>Switch SW1 must be set to ACI in order to use a 0 to 20mA input</b>                |
|           | 05 | Frequency determined by RS-232/RS-485 communication interface ( <i>RS-232 or RS-485 communication selected by switches SW2 and SW3. Refer to CHAPTER 5 for details.</i> ) |

The frequency of the AC drive will be determined by keypad potentiometer.

### **P 6.00**

### **Electronic Thermal Overload Relay**

**Setting: 01**

Default Setting: 00

Settings: 00 - Constant Torque (inverter/vector duty motor)  
01 - Variable Torque (fan-cooled standard motor)  
02 - Inactive

This function setting 01 is used to derate the AC drive output current overload protection to protect a fan-cooled standard motor running at low speeds.

### **P 8.00**

### **User Defined Display Function**

**Setting: 03**

Default Setting: 00

Settings:

|    |                           |
|----|---------------------------|
| 00 | Output Frequency (Hz)     |
| 01 | Motor Speed (rpm)         |
| 02 | Output Frequency x P 8.01 |
| 03 | Output Current (A)        |
| 04 | Motor Output Current (%)  |
| 05 | Output Voltage(V)         |
| 06 | DC Bus Voltage (V)        |
| 07 | PID Setpoint              |
| 08 | PID Feedback (PV)         |
| 09 | Frequency Setpoint        |

The AC drive display will default to indicate Output Current (A) when running.



---

*Note: For a complete list and description of the parameters for the GS2 Series AC drives, refer to CHAPTER 4.*

---

# AC DRIVE PARAMETERS

---



# CHAPTER 4

## In This Chapter...

|   |      |
|---|------|
| GS2 Parameter Summary . . . . .                             | 4-2  |
| Detailed Parameter Listings . . . . .                       | 4-11 |
| Motor Parameters . . . . .                                  | 4-11 |
| Ramp Parameters . . . . .                                   | 4-13 |
| Volts/Hertz Parameters . . . . .                            | 4-19 |
| Digital Parameters . . . . .                                | 4-22 |
| Setting Explanations for parameters P3.02 - P3.05 . . . . . | 4-24 |
| Analog Parameters . . . . .                                 | 4-32 |
| Analog Input Examples . . . . .                             | 4-34 |
| Preset Parameters . . . . .                                 | 4-41 |
| Protection Parameters . . . . .                             | 4-43 |
| PID Parameters . . . . .                                    | 4-51 |
| Display Parameters . . . . .                                | 4-55 |
| Communication Parameters . . . . .                          | 4-56 |

## GS2 Parameter Summary

| Motor Parameters |                         |   |                        |
|------------------|-------------------------|---|------------------------|
| GS2 Parameter    | Description             | Range   | Default                |
| P0.00            | Motor Nameplate Voltage | 115V/230V: 200/208/220/230/240<br>460V: 380/400/415/440/460/480<br>575V: 380 to 637 | 240<br>480<br>575      |
| P0.01            | Motor Nameplate Amps    | Drive Rated Amps X .3 to 1.0  | Drive Rated Amps x 1.0 |
| P0.02            | Motor Base Frequency    | 50/60/400   | 60                     |
| P0.03            | Motor Base RPM          | 375 to 9999 RPM   | 1750                   |
| P0.04            | Motor Maximum RPM       | P0.03 to 9999 RPM   | P0.03                  |

| Ramp Parameters |  |  |      |
|-----------------|--|--|------|
| P1.00           | Stop Methods                               | 00: Ramp to Stop<br>01: Coast to Stop                                    | 00   |
| ◆ P1.01         | Acceleration Time 1                        | 0.1 to 600.0 sec   | 10.0 |
| ◆ P1.02         | Deceleration Time 1                        | 0.1 to 600.0 sec   | 30.0 |
| P1.03           | Accel S-curve                              | 0 to 7   | 00   |
| P1.04           | Decel S-curve                              | 0 to 7   | 00   |
| ◆ P1.05         | Acceleration Time 2                        | 0.1 to 600.0 sec   | 10.0 |
| ◆ P1.06         | Deceleration Time 2                        | 0.1 to 600.0 sec   | 30.0 |
| P1.07           | Select method to use<br>2nd Accel/Decel    | 00: RMP2 from DI terminal<br>01: Transition Frequencies<br>P1.08 & P1.09 | 00   |
| P1.08           | Accel 1 to Accel 2<br>frequency transition | 0.0 to 400.0 Hz  | 0.0  |
| P1.09           | Decel 2 to Decel 1<br>frequency transition | 0.0 to 400.0 Hz  | 0.0  |
| P1.10           | Skip Frequency 1                           | 0.0 to 400.0 Hz  | 0.0  |
| P1.11           | Skip Frequency 2                           | 0.0 to 400.0 Hz  | 0.0  |
| P1.12           | Skip Frequency 3                           | 0.0 to 400.0 Hz  | 0.0  |
| P1.17           | Skip Frequency Band                        | 0.0 to 20.0 Hz   | 0.0  |
| P1.18           | DC Injection Current Level                 | 00 to 100 %  | 00   |
| P1.20           | DC Injection during Start-up               | 0.0 to 5.0 sec   | 0.0  |
| P1.21           | DC Injection during Stopping               | 0.0 to 25.0 sec  | 0.0  |
| P1.22           | Start-point for DC Injection               | 0.0 to 60.0 Hz   | 0.0  |

◆ Parameter can be set during RUN Mode.

| Volts/Hertz Parameters |                       |   |                      |
|------------------------|-----------------------|---|----------------------|
| GS2 Parameter          | Description           | Range   | Default              |
| <b>P2.00</b>           | Volts/Hertz Settings  | 00: General Purpose<br>01: High Starting Torque<br>02: Fans and Pumps<br>03: Custom | 00                   |
| ◆ <b>P2.01</b>         | Slip Compensation     | 0.0 to 10.0   | 0.0                  |
| ◆ <b>P2.02</b>         | Auto-torque Boost     | 00 to 10  | 00                   |
| <b>P2.04</b>           | Mid-point Frequency   | 0.1 to 400 Hz   | 1.5                  |
| <b>P2.05</b>           | Mid-point Voltage     | 115V/230V: 2.0 to 255V<br>460V: 2.0 to 510V<br>575V: 2.0 to 637V                    | 10.0<br>20.0<br>24.0 |
| <b>P2.06</b>           | Min. Output Frequency | 0.1 to 20.0 Hz  | 1.50                 |
| <b>P2.07</b>           | Min. Output Voltage   | 115V/230V: 2.0 to 50.0V<br>460V: 2.0 to 100.0V<br>575V: 2.0 to 130.6V               | 10.0<br>20.0<br>24.0 |
| <b>P2.08</b>           | PWM Carrier Frequency | 115V/230V/460V: 01 to 15 kHz<br>575V: 01 to 10 kHz                                  | 12<br>6              |

| Digital Parameters |  |  |    |
|--------------------|--|--|----|
| <b>P3.00</b>       | Source of Operation Command                | 00: Operation determined by digital keypad<br>01: Operation determined by external control terminals, keypad STOP is enabled<br>02: Operation determined by external control terminals, keypad STOP is disabled<br>03: Operation determined by RS-485 interface, keypad STOP is enabled<br>04: Operation determined by RS-485 interface, keypad STOP is disabled | 00 |
| <b>P3.01</b>       | Multi-function Input Terminals (DI1 - DI2) | 00: DI1 - FWD / STOP, DI2 - REV / STOP<br>01: DI1 - RUN / STOP, DI2 - REV / FWD<br>02: DI1 - RUN momentary (N.O.)<br>DI2 - REV / FWD<br>DI3 - STOP momentary (N.C.)  | 00 |

◆ Parameter can be set during RUN Mode.

| Digital Parameters (cont.) |                                  |  |         |
|----------------------------|----------------------------------|--|---------|
| GS2 Parameter              | Description                      | Range  | Default |
| <b>P3.02</b>               | Multi-function Input (DI3)       | 00: External Fault (N.O.)<br>01: External Fault (N.C.)<br>02: External Reset<br>03: Multi-Speed/PID SP Bit 1<br>04: Multi-Speed/PID SP Bit 2 | 00      |
| <b>P3.03</b>               | Multi-function Input (DI4)       | 05: Multi-Speed/PID SP Bit 3<br>06: Reserved<br>07: Reserved<br>08: Reserved<br>09: Jog  | 03      |
| <b>P3.04</b>               | Multi-function Input (DI5)       | 10: External Base Block (N.O.)<br>11: External Base Block (N.C.)<br>12: Second Accel/Decel Time<br>13: Speed Hold<br>14: Increase Speed      | 04      |
| <b>P3.05</b>               | Multi-function Input (DI6)       | 15: Decrease Speed<br>16: Reset Speed to Zero<br>17: PID Disable (N.O.)<br>18: PID Disable (N.C.)<br>99: Input Disable                       | 05      |
| <b>P3.11</b>               | Multi-Function Output Terminal 1 | 00: AC Drive Running<br>01: AC Drive Fault<br>02: At Speed<br>03: Zero Speed<br>04: Above Desired Frequency<br>05: Below Desired Frequency   | 00      |
| <b>P3.12</b>               | Multi-Function Output Terminal 2 | 06: At Maximum Speed<br>07: Over torque detected<br>08: Above Desired Current<br>09: Below Desired Current<br>10: PID Deviation Alarm        | 01      |
| ◆ <b>P3.16</b>             | Desired Frequency                | 0.0 to 400.0 Hz  | 0.0     |
| ◆ <b>P3.17</b>             | Desired Current                  | 0.0 to <Drive Rated Amps>  | 0.0     |
| ◆ <b>P3.18</b>             | PID Deviation Level              | 1.0 to 50.0 %  | 10.0    |
| ◆ <b>P3.19</b>             | PID Deviation Time               | 0.1 to 300.0 sec   | 5.0     |

◆ Parameter can be set during RUN Mode.

| Analog Parameters |                                    |   |         |
|-------------------|------------------------------------|---|---------|
| GS2 Parameter     | Description                        | Range   | Default |
| P4.00             | Source of Frequency Command        | 00: Frequency determined by keypad potentiometer<br>01: Frequency determined by digital keypad up/down<br>02: Frequency determined by 0 to +10V input on AI terminal with jumpers<br>03: Frequency determined by 4 to 20mA input on AI terminal with jumpers<br>04: Frequency determined by 0 to 20mA input on AI terminal with jumpers<br>05: Frequency determined by RS-232C/RS-485 communication interface | 00      |
| P4.01             | Analog Input Offset Polarity       | 00: No Offset<br>01: Positive Offset<br>02: Negative Offset   | 00      |
| ◆ P4.02           | Analog Input Offset                | 0.0 to 100.0%   | 0.0     |
| ◆ P4.03           | Analog Input Gain                  | 0.0 to 300.0%   | 100.0   |
| P4.04             | Analog Input Reverse Motion Enable | 00: Forward Motion Only<br>01: Reverse Motion Enable  | 00      |
| P4.05             | Loss of ACI Signal (4-20mA)        | 00: Decelerate to 0Hz<br>01: Stop immediately and display error code "EF"<br>02: Continue operation by the last frequency command   | 00      |
| ◆ P4.11           | Analog Output Signal               | 00: frequency Hz<br>01: Current A<br>02: PV   | 00      |
| ◆ P4.12           | Analog Output Gain                 | 00 to 200%  | 100     |

| Presets |               |                 |     |
|---------|---------------|-----------------|-----|
| ◆ P5.00 | Jog           | 0.0 to 400.0 Hz | 6.0 |
| ◆ P5.01 | Multi-Speed 1 | 0.0 to 400.0 Hz | 0.0 |
| ◆ P5.02 | Multi-Speed 2 | 0.0 to 400.0 Hz | 0.0 |
| ◆ P5.03 | Multi-Speed 3 | 0.0 to 400.0 Hz | 0.0 |
| ◆ P5.04 | Multi-Speed 4 | 0.0 to 400.0 Hz | 0.0 |
| ◆ P5.05 | Multi-Speed 5 | 0.0 to 400.0 Hz | 0.0 |
| ◆ P5.06 | Multi-Speed 6 | 0.0 to 400.0 Hz | 0.0 |
| ◆ P5.07 | Multi-Speed 7 | 0.0 to 400.0 Hz | 0.0 |

◆ Parameter can be set during RUN Mode.

| Protection Parameters |   |   |         |
|-----------------------|---|---|---------|
| GS2 Parameter         | Description                                       | Range   | Default |
| <b>P6.00</b>          | Electronic Thermal Overload Relay                 | 00: Constant Torque<br>01: Variable Torque<br>02: Inactive  | 00      |
| <b>P6.01</b>          | Auto Restart after Fault                          | 00 to 10  | 00      |
| <b>P6.02</b>          | Momentary Power Loss                              | 00: Stop operation after momentary power loss<br>01: Continue operation after momentary power loss, speed search from Speed Reference<br>02: Continue operation after momentary power loss, speed search from Minimum Speed | 00      |
| <b>P6.03</b>          | Reverse Operation Inhibit                         | 00: Enable Reverse Operation<br>01: Disable Reverse Operation   | 00      |
| <b>P6.04</b>          | Auto Voltage Regulation                           | 00: AVR enabled<br>01: AVR disabled<br>02: AVR disabled during decel<br>03: AVR disabled during stop  | 00      |
| <b>P6.05</b>          | Over-Voltage Stall Prevention                     | 00: Enable Over-voltage Stall Prevention<br>01: Disable Over-voltage Stall Prevention   | 00      |
| <b>P6.06</b>          | Auto Adjustable Accel/Decel                       | 00: Linear Accel/Decel<br>01: Auto Accel, Linear Decel<br>02: Linear Accel, Auto Decel<br>03: Auto Accel/Decel<br>04: Auto Accel/Decel Stall Prevention (limited by P1.01, P1.02, P1.05, P1.06)                             | 00      |
| <b>P6.07</b>          | Over-Torque Detection Mode                        | 00: Disabled<br>01: Enabled during constant speed operation<br>02: Enabled during acceleration  | 00      |
| <b>P6.08</b>          | Over-Torque Detection Level                       | 30 to 200%  | 150     |
| <b>P6.09</b>          | Over-Torque Detection Time                        | 0.1 to 10.0   | 0.1     |
| <b>P6.10</b>          | Over-Current Stall Prevention during Acceleration | 20 to 200%  | 150     |
| <b>P6.11</b>          | Over-Current Stall Prevention during Operation    | 20 to 200%  | 150     |
| <b>P6.12</b>          | Maximum Allowable Power Loss Time                 | 0.3 to 5.0 sec  | 2.0     |
| <b>P6.13</b>          | Base-Block Time for Speed Search                  | 0.3 to 5.0 sec  | 0.5     |
| <b>P6.14</b>          | Maximum Speed Search Current Level                | 30 to 200%  | 150     |
| <b>P6.15</b>          | Upper Bound of Output Frequency                   | 0.1 to 400Hz  | 400     |
| <b>P6.16</b>          | Lower Bound of Output Frequency                   | 0.0 to 400Hz  | 0.0     |
| <b>P6.30</b>          | Line Start Lockout                                | 00: Enable Line Start Lockout<br>01: Disable Line Start Lockout   | 00      |

◆ Parameter can be set during RUN Mode.



| Protection Parameters (cont.) |                                 |  |         |
|-------------------------------|---------------------------------|--|---------|
| GS2 Parameter                 | Description                     | Range  | Default |
| P6.31                         | Present Fault Record            | 00: No Fault occurred<br>01: Over-current (oc)<br>02: Over-voltage (ov)<br>03: Overheat (oH)   | 00      |
| P6.32                         | Second Most Recent Fault Record | 04: Overload (oL)<br>05: Overload 1 (oL1)<br>06: Overload 2 (oL2)  | 00      |
| P6.33                         | Third Most Recent Fault Record  | 07: External Fault (EF)<br>08: CPU failure 1 (CF1)<br>09: CPU failure 2 (CF2)<br>10: CPU failure 3 (CF3)   | 00      |
| P6.34                         | Fourth Most Recent Fault Record | 11: Hardware Protection Failure (HPF)<br>12: Over-current during accel (OCA)<br>13: Over-current during decel (OCd)                              | 00      |
| P6.35                         | Fifth Most Recent Fault Record  | 14: Over-current during steady state (OCn)<br>15: Ground fault or fuse failure (GFF)<br>16: Reserved   | 00      |
| P6.36                         | Sixth Most Recent Fault Record  | 17: Input power 3-phase loss<br>18: External Base-Block (bb)<br>19: Auto Adjust accel/decel failure (cFA)<br>20: Software protection code (codE) | 00      |

◆ Parameter can be set during RUN Mode.

| PID Parameters |                                  |  |         |
|----------------|----------------------------------|--|---------|
| GS2 Parameter  | Description                      | Range  | Default |
| <b>P7.00</b>   | Input Terminal for PID Feedback  | 00: Inhibit PID operation<br>01: Forward-acting (heating loop) PID feedback, PV from AVI (0 to + 10V)<br>02: Forward-acting (heating loop) PID feedback, PV from ACI (4 to 20mA)<br>03: Reverse-acting (cooling loop) PID feedback, PV from AVI (0 to +10V).<br>04: Reverse-acting (cooling loop) PID feedback, PV from ACI (4 to 20mA). | 00      |
| <b>P7.01</b>   | PV 100% Value                    | 0.0 to 999   | 100.0   |
| <b>P7.02</b>   | PID Setpoint Source              | 00: Keypad<br>01: Serial Communications  | 00      |
| ◆ <b>P7.10</b> | Keypad PID Setpoint              | 0.0 to 999   | 0.0     |
| ◆ <b>P7.11</b> | PID Multi-setpoint 1             | 0.0 to 999   | 0.0     |
| ◆ <b>P7.12</b> | PID Multi-setpoint 2             | 0.0 to 999   | 0.0     |
| ◆ <b>P7.13</b> | PID Multi-setpoint 3             | 0.0 to 999   | 0.0     |
| ◆ <b>P7.14</b> | PID Multi-setpoint 4             | 0.0 to 999   | 0.0     |
| ◆ <b>P7.15</b> | PID Multi-setpoint 5             | 0.0 to 999   | 0.0     |
| ◆ <b>P7.16</b> | PID Multi-setpoint 6             | 0.0 to 999   | 0.0     |
| ◆ <b>P7.17</b> | PID Multi-setpoint 7             | 0.0 to 999   | 0.0     |
| ◆ <b>P7.20</b> | Proportional Control             | 0.0 to 10.0  | 1.0     |
| ◆ <b>P7.21</b> | Integral Control                 | 0.00 to 100.0 sec  | 1.00    |
| ◆ <b>P7.22</b> | Derivative Control               | 0.00 to 1.00 sec   | 0.00    |
| <b>P7.23</b>   | Upper Bound for Integral Control | 00 to 100%   | 100     |
| <b>P7.24</b>   | Derivative Filter Time Constant  | 0.0 to 2.5 sec   | 0.0     |
| <b>P7.25</b>   | PID Output Frequency Limit       | 00 to 110%   | 100     |
| <b>P7.26</b>   | Feedback Signal Detection Time   | 0.0 to 3600 sec.   | 60      |
| <b>P7.27</b>   | PID Feedback Loss                | 00: Warn and AC Drive Stop<br>01: Warn and Continue Operation  | 00      |

| Display Parameters |                               |  |     |
|--------------------|-------------------------------|--|-----|
| ◆ <b>P8.00</b>     | User Defined Display Function | 00: Output Frequency (Hz)<br>01: Motor Speed (RPM)<br>02: Output Freq. X P8.01<br>03: Output Current (A)<br>04: Motor Output Current (%)<br>05: Output Voltage (V)<br>06: DC Bus Voltage (V)<br>07: PID Setpoint<br>08: PID Feedback Signal (PV)<br>09: Frequency Setpoint | 00  |
| ◆ <b>P8.01</b>     | Frequency Scale Factor        | 0.01 to 160.0  | 1.0 |

◆ Parameter can be set during RUN Mode.

| Communications Parameters |                              |  |         |
|---------------------------|------------------------------|--|---------|
| GS2 Parameter             | Description                  | Range  | Default |
| <b>P9.00</b>              | Communication Address        | 01 to 254  | 01      |
| <b>P9.01</b>              | Transmission Speed           | 00: 4800 baud<br>01: 9600 baud<br>02: 19200 baud<br>03: 38400 baud   | 01      |
| <b>P9.02</b>              | Communication Protocol       | 00: Modbus ASCII mode<br>7 data bits, no parity, 2 stop bits<br>01: Modbus ASCII mode<br>7 data bits, even parity, 1 stop bit<br>02: Modbus ASCII mode<br>7 data bits, odd parity, 1 stop bit<br>03: Modbus RTU mode<br>8 data bits, no parity, 2 stop bits<br>04: Modbus RTU mode<br>8 data bits, even parity, 1 stop bit<br>05: Modbus RTU mode<br>8 data bits, odd parity, 1 stop bit | 00      |
| <b>P9.03</b>              | Transmission Fault Treatment | 00: Display fault and continue operating<br>01: Display fault and RAMP to stop<br>02: Display fault and COAST to stop<br>03: No fault displayed and continue operating   | 00      |
| <b>P9.04</b>              | Time Out Detection           | 00: Disable<br>01: Enable  | 00      |
| <b>P9.05</b>              | Time Out Duration            | 0.1 to 60.0 seconds  | 0.5     |
| ◆ <b>P9.07</b>            | Parameter Lock               | 00: All parameters can be set and read<br>01: All parameters are read-only   | 00      |
| <b>P9.08</b>              | Restore to Default           | 99: Restores all parameters to factory defaults  | 00      |
| ◆ <b>P9.11</b>            | Block Transfer Parameter 1   | P0.00 to P8.01, P9.99  | P9.99   |
| ◆ <b>P9.12</b>            | Block Transfer Parameter 2   | P0.00 to P8.01, P9.99  | P9.99   |
| ◆ <b>P9.13</b>            | Block Transfer Parameter 3   | P0.00 to P8.01, P9.99  | P9.99   |
| ◆ <b>P9.14</b>            | Block Transfer Parameter 4   | P0.00 to P8.01, P9.99  | P9.99   |
| ◆ <b>P9.15</b>            | Block Transfer Parameter 5   | P0.00 to P8.01, P9.99  | P9.99   |
| ◆ <b>P9.16</b>            | Block Transfer Parameter 6   | P0.00 to P8.01, P9.99  | P9.99   |
| ◆ <b>P9.17</b>            | Block Transfer Parameter 7   | P0.00 to P8.01, P9.99  | P9.99   |
| ◆ <b>P9.18</b>            | Block Transfer Parameter 8   | P0.00 to P8.01, P9.99  | P9.99   |
| ◆ <b>P9.19</b>            | Block Transfer Parameter 9   | P0.00 to P8.01, P9.99  | P9.99   |
| ◆ <b>P9.20</b>            | Block Transfer Parameter 10  | P0.00 to P8.01, P9.99  | P9.99   |
| ◆ <b>P9.21</b>            | Block Transfer Parameter 11  | P0.00 to P8.01, P9.99  | P9.99   |
| ◆ <b>P9.22</b>            | Block Transfer Parameter 12  | P0.00 to P8.01, P9.99  | P9.99   |

◆ Parameter can be set during RUN Mode.

| Communications Parameters (continued) |                                |   |         |
|---------------------------------------|--------------------------------|---|---------|
| GS2 Parameter                         | Description                    | Range   | Default |
| ◆ P9.23                               | Block Transfer Parameter 13    | P0.00 to P8.01  | P9.99   |
| ◆ P9.24                               | Block Transfer Parameter 14    | P0.00 to P8.01  | P9.99   |
| ◆ P9.25                               | Block Transfer Parameter 15    | P0.00 to P8.01  | P9.99   |
| ◆ P9.26                               | Serial Comm Speed Reference    | 0.0 to 400.0 Hz   | 60.0    |
| ◆ P9.27                               | Serial Comm RUN Command        | 00: Stop<br>01: Run   | 00      |
| ◆ P9.28                               | Serial Comm Direction Command  | 00: Forward<br>01: Reverse  | 00      |
| ◆ P9.29                               | Serial Comm External Fault     | 00: No fault<br>01: External fault  | 00      |
| ◆ P9.30                               | Serial Comm Fault Reset        | 00: No action<br>01: Fault Reset  | 00      |
| ◆ P9.31                               | Serial Comm JOG Command        | 00: Stop<br>01: Jog   | 00      |
| P9.39                                 | Firmware Version               | ###   | ###     |
| P9.41                                 | GS Series Number               | 01: GS1<br>02: GS2<br>03: GS3   | ##      |
| P9.42                                 | Manufacturer Model Information | 00: GS2-20P5 (230V 1ph/3ph 0.5hp)<br>01: GS2-21P0 (230V 1ph/3ph 1hp)<br>02: GS2-22P0 (230V 1ph/3ph 2hp)<br>03: GS2-23P0 (230V 1ph/3ph 3hp)<br>04: GS2-25P0 (230V 3ph 5hp)<br>05: GS2-27P5 (230V 3ph 7.5hp)<br>06: Reserved<br>07: GS2-41P0 (460V 3ph 1hp)<br>08: GS2-42P0 (460V 3ph 2hp)<br>09: GS2-43P0 (460V 3ph 3hp)<br>10: GS2-45P0 (460V 3ph 5hp)<br>11: GS2-47P5 (460V 3ph 7.5hp)<br>12: GS2-4010 (460V 3ph 10hp)<br>13: GS2-10P2 (115V 1ph 0.25hp)<br>14: GS2-10P5 (115V 1ph 0.5hp)<br>15: GS2-11P0 (115V 1ph 1hp)<br>16~20: Reserved<br>21: GS2-51P0 (575V 3ph 1hp)<br>22: GS2-52P0 (575V 3ph 2hp)<br>23: GS2-53P0 (575V 3ph 3hp)<br>24: GS2-55P0 (575V 3ph 5hp)<br>25: GS2-57P5 (575V 3ph 7.5hp)<br>26: GS2-5010 (575V 3ph 10hp) | ##      |

◆ Parameter can be set during RUN Mode.

## Detailed Parameter Listings

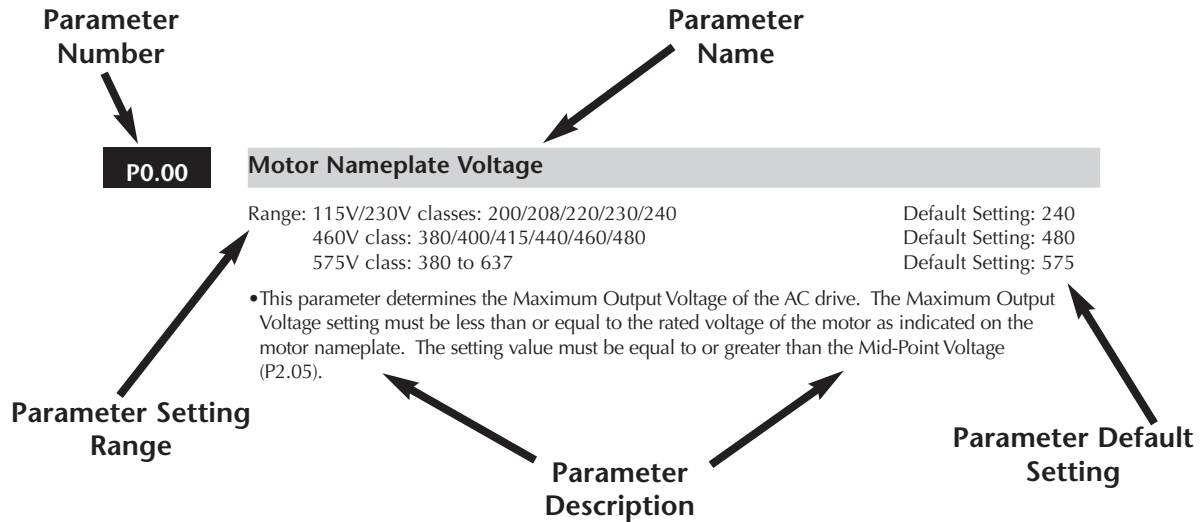

*Note: If the ◆ symbol is found next to the parameter name, the parameter can be edited when the AC drive is in RUN Mode.*

## Motor Parameters

### **P0.00** Motor Nameplate Voltage

Range: 115V/230V classes: 200/208/220/230/240      Default Setting: 240  
460V class: 380/400/415/440/460/480      480  
575V class: 380 to 637      575

This parameter determines the Maximum Output Voltage of the AC drive. The Maximum Output Voltage setting must be less than or equal to the rated voltage of the motor as indicated on the motor nameplate. The setting value must be equal to or greater than the Mid-Point Voltage (P2.05).

### **P0.01** Motor Nameplate Amps

Range: Drive Rated Amps x 0.3 to      Default Setting: Drive Rating (A)  
Drive Rated Amps x 1.0

This parameter sets the output current to the motor, and is used by the drive to set the motor overload protection. Set this parameter value to the full load current listed on the motor nameplate. (Also refer to P6.00 to set overload curve type.)

### P0.02 Motor Base Frequency

Range: 50/60/400

Default Setting 60

- This value should be set according to base frequency of the motor as indicated on the motor nameplate. Motor Base Frequency determines the volts per hertz ratio.

### P0.03 Motor Base RPM

Range: 375 to 9999 RPM

Default Setting: 1750

- This value should be set according to rated Base RPM of the motor as indicated on the motor nameplate.

### P0.04 Motor Maximum RPM

Range: P0.03 to 9999 RPM

Default Setting: P0.03

- This value should be set according to the desired maximum speed of the motor. This value should not exceed the motor's maximum rated speed.



**WARNING: The Motor Maximum RPM parameter (P0.04) should never exceed the maximum speed rating for the motor you are using. If this information is not readily available, consult your motor manufacturer.**

- This value cannot be set lower than Motor Base RPM (P0.03).

This parameter, along with P0.02 and P0.03, determines the Maximum Output Frequency of the AC Drive. The Maximum Output Frequency can be calculated as follows:

$$\text{Max. Output Frequency} = \left( \frac{\text{Motor Max. RPM (P0-04)}}{\text{Motor Base RPM (P0-03)}} \right) \times \text{Base Frequency (P0-02)}$$

- If an output limit based on Maximum Output Frequency is desired, use the following equation to determine the corresponding value for Motor Maximum RPM:

$$\text{Motor Maximum RPM} = \left( \frac{\text{Max. Output Frequency}}{\text{Motor Base Frequency (P 0.02)}} \right) \times \text{Motor Base RPM (P 0.03)}$$

# Ramp Parameters

## P1.00 Stop Methods

Range: 00 Ramp to Stop  
01 Coast to stop

Default Setting: 00

This parameter determines how the motor is stopped when the AC drive receives a valid stop command.

- Ramp: The AC drive decelerates the motor to Minimum Output Frequency (P2.06) and then stops according to the deceleration time set in P1.02 or P1.06.
- Coast: The AC drive stops output instantly upon command, and the motor free runs until it comes to a complete stop.



*Note: The drive application or system requirements will determine which stop method is needed.*

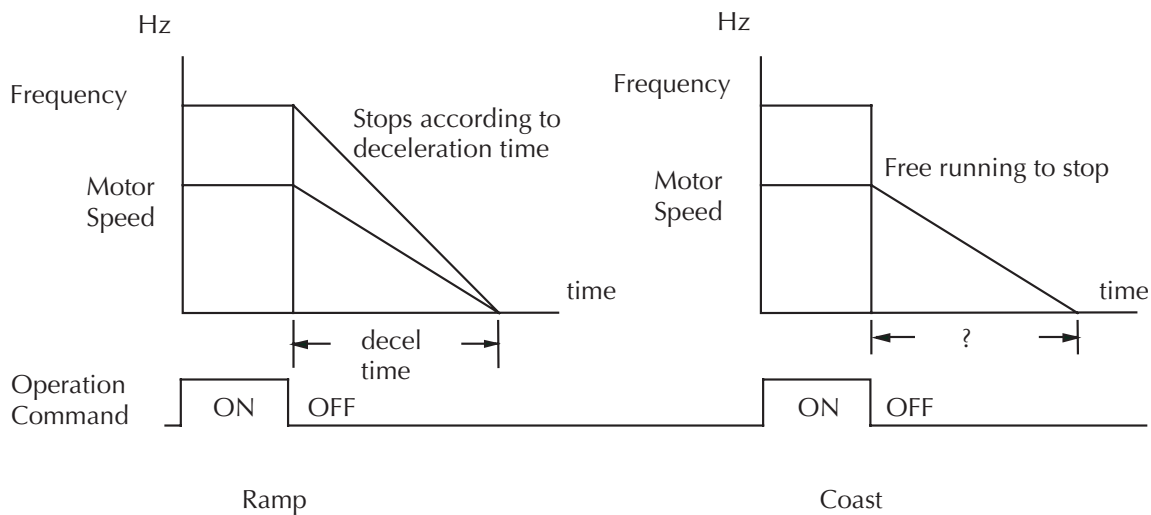

## P1.01 Acceleration Time 1

Range: 0.1 to 600 sec

Default Setting: 10 sec

This parameter is used to determine the time required for the AC drive to ramp from 0 to its Maximum Motor RPM (P0.04). The rate is linear unless S-Curve is "Enabled."

### P1.02 ◆ Deceleration Time 1

Range: 0.1 to 600 sec

Default Setting: 30 sec

This parameter is used to determine the time required for the AC drive to decelerate from the Maximum Motor RPM (P0.04) down to 0Hz. The rate is linear unless S-Curve is "Enabled."

### P1.03 Accel S-Curve

Range: 00 to 07

Default Setting: 00

This parameter is used whenever the motor and load need to be accelerated more smoothly. The Accel S-Curve may be set from 0 to 7 to select the desired acceleration S Curve.

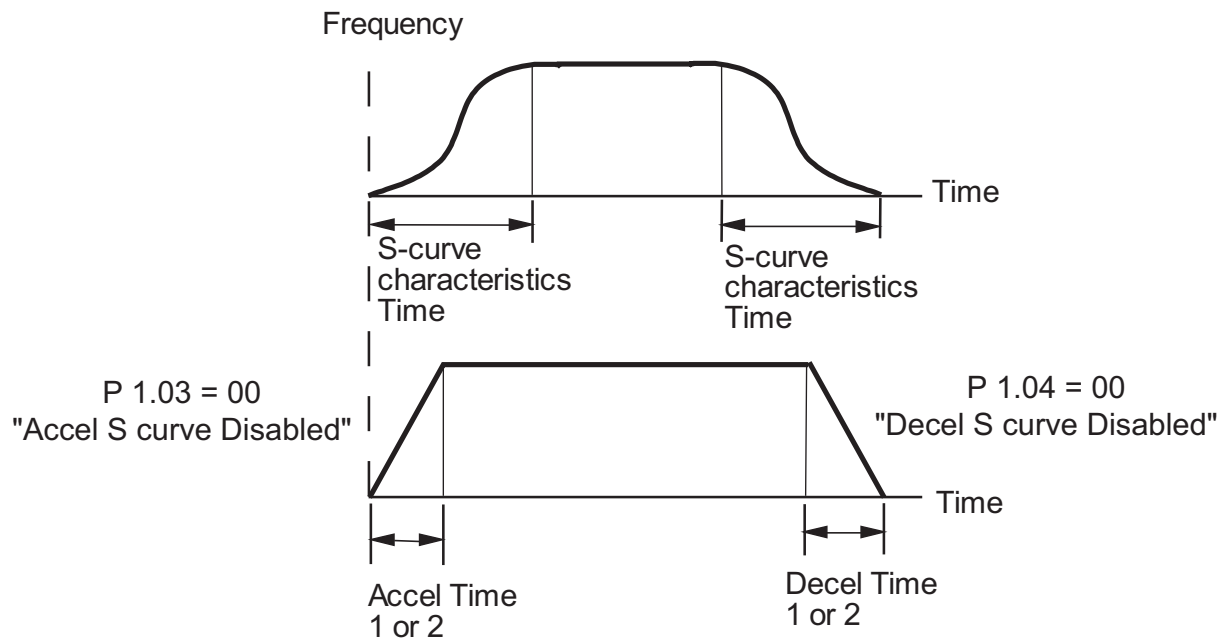



**P1.04 Decel S-Curve**

Range: 00 to 07

Default Setting: 00

This parameter is used whenever the motor and load need to be decelerated more smoothly. The Decel S-Curve may be set from 00 to 07 to select the desired deceleration S-Curve.

Note: From the diagram shown below, the original setting accel/decel time will be for reference when the function of the S-curve is enabled. The actual accel/decel time will be determined based on the S-curve selected (1 to 7).

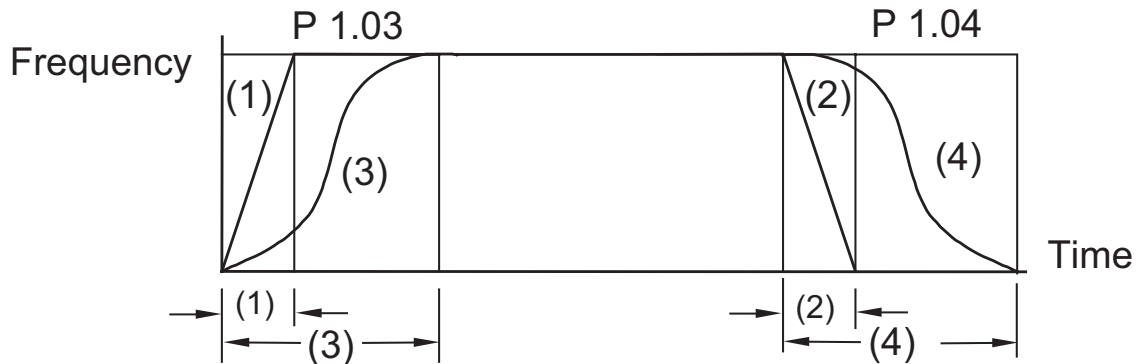

S curve is disabled in (1), (2)  
 P 1.03 sets S curve for (3)  
 P 1.04 sets S curve for (4)

**P1.05 ◆ Acceleration Time 2**

Range: 0.1 to 600 sec

Default Setting: 10.0

- The Second Acceleration Time determines the time for the AC drive to accelerate from 0 RPM to Maximum Motor RPM (P0.04). Acceleration Time 2 (P1.05) can be selected using a multi-function input terminal or frequency transition (P1.07).

**P1.06 ◆ Deceleration Time 2**

Range: 0.1 to 600 sec

Default Setting: 30 sec

- The Second Deceleration Time determines the time for the AC drive to decelerate from Maximum Motor RPM (P0.04) to 0 RPM. Deceleration Time 2 (P1.06) can be selected using a multi-function input terminal or frequency transition (P1.07).

### P1.07 Select method for 2nd Accel/Decel

Range: 00: Second Accel/Decel from DI terminal  
 01: Frequency Transition  
 P1.08 & P1.09

Default Setting: 00

- The second set of acceleration and deceleration times P1.05 and P1.06 can be selected either with a multi-function input terminal programmed to Second Accel/Decel, or by the values of the transition frequencies P1.08 and P1.09

#### Second Accel/Decel Times selected with Multi-Function Input Terminal

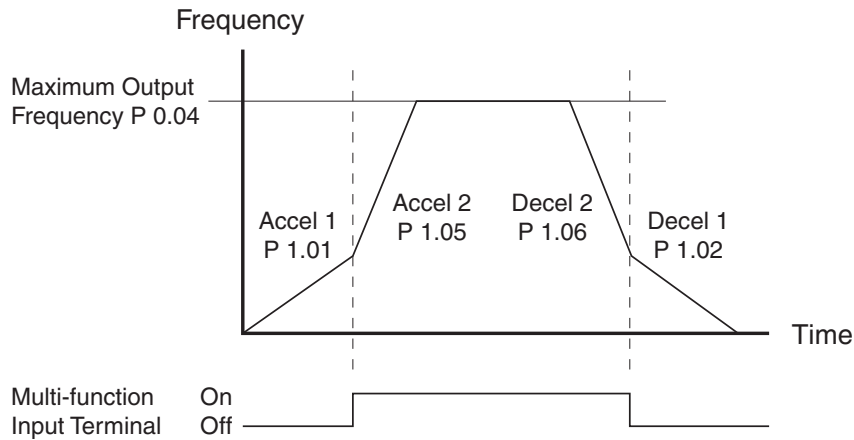

### P1.08 Accel 1 to Accel 2 Frequency Transition

Range: 0.0 to 400.0 Hz

Default Setting: 0.0

#### Second Accel/Decel Times selected with Frequency Transition

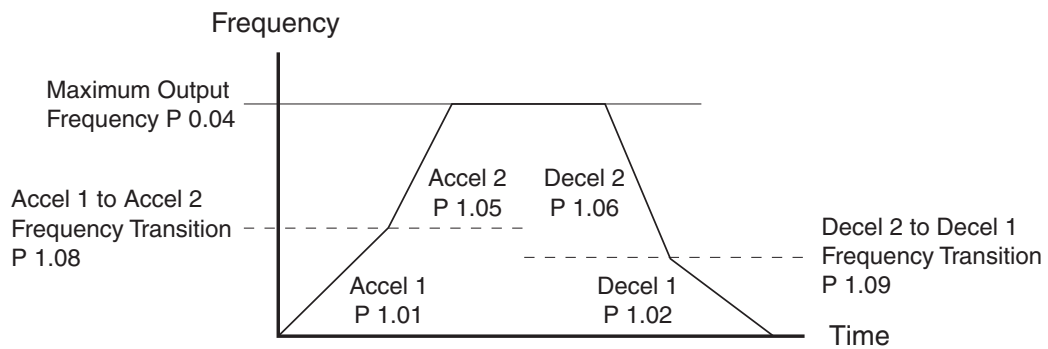

### P1.09 Decel 1 to Decel 2 Frequency Transition

Range: 0.0 to 400.0 Hz

Default Setting: 0.0

**P1.10 Skip Frequency 1**

Range: 0.0 to 400.0 Hz Default Setting: 0.0

**P1.11 Skip Frequency 2**

Range: 0.0 to 400.0 Hz Default Setting: 0.0

**P1.12 Skip Frequency 3**

Range: 0.0 to 400.0 Hz Default Setting: 0.0

- P1.10, P1.11, and P1.12 determine the location of the frequency bands that will be skipped during AC drive operation.

**P1.17 Skip Frequency Band**

Range: 0.0 to 20.0 Hz Default Setting: 0.0

This parameter determines the frequency band for a given Skip Frequency (P1.10, P1.11, or P1.12). Half of the Skip Frequency Band is above the Skip Frequency and the other half is below. Programming this parameter to 0.0 disables all skip frequencies.

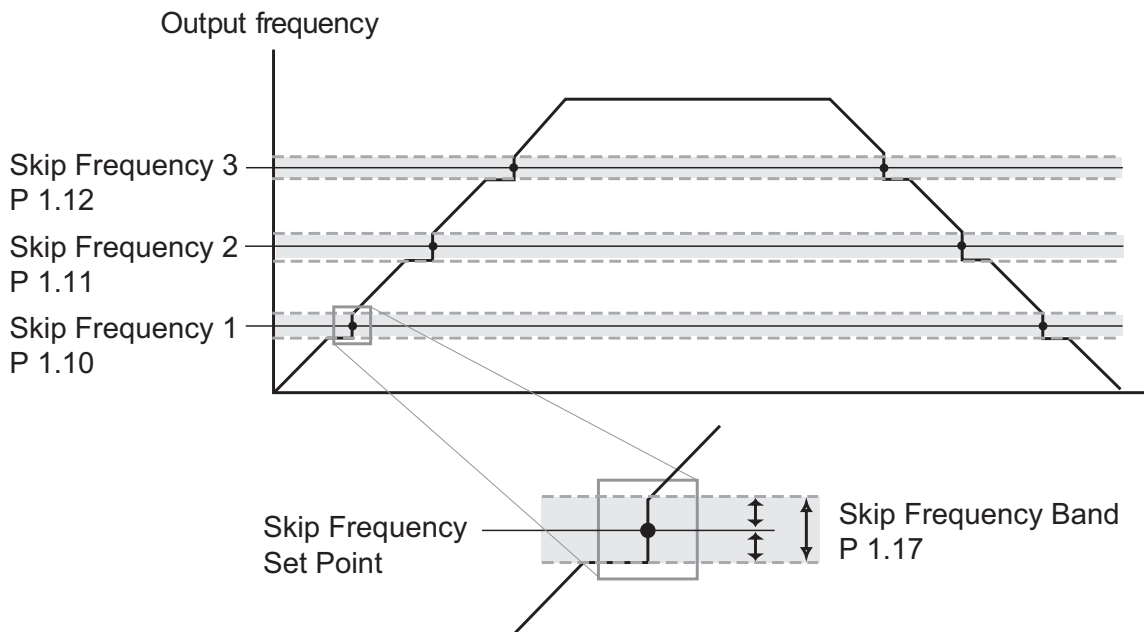

### P1.18 DC Injection Current Level

Range: 00 to 100%

Default Setting: 00

This parameter determines the amount of DC Braking Current applied to the motor during start-up and stopping. When setting DC Braking Current, please note that 100% is equal to the rated current of the drive. It is recommended to start with a low DC Braking Current Level and then increase until proper holding torque has been attained.

### P1.20 DC Injection during Start-up

Range: 0.0 to 5.0 sec

Default Setting: 0.0

This parameter determines the duration of time that the DC Braking Current will be applied to the motor during the AC drive start-up. DC Braking will be applied for the time set in this parameter until the Minimum Frequency is reached during acceleration.

### P1.21 DC Injection during Stopping

Range: 0.0 to 25.0 sec

Default Setting: 0.0

This parameter determines the duration of time that the DC braking voltage will be applied to the motor during stopping. If stopping with DC Braking is desired, then P1.00 must be set to Ramp to Stop (00).

### P1.22 Start-point for DC Injection

Range: 0.0 to 60.0 Hz

Default Setting: 0.0

This parameter determines the frequency when DC Braking will begin during deceleration.

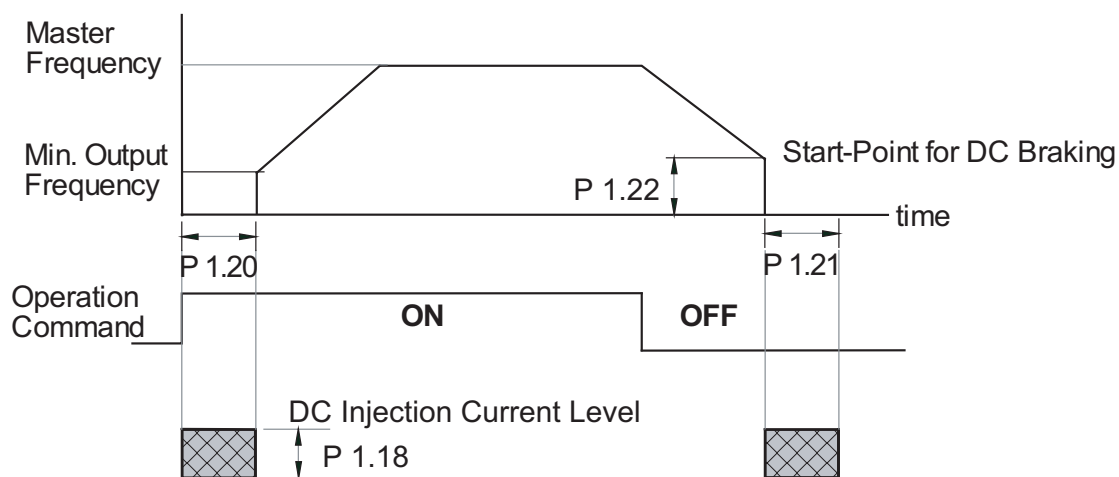

# Volts/Hertz Parameters

## P2.00 Volts/Hertz Settings

- Settings: 00 - General Purpose (constant torque) Default Setting: 0.0  
 01 - High Starting Torque  
 02 - Fans and Pumps (variable torque)  
 03 - Custom



*Note: P2.04 through P2.07 are only used when the Volts/Hertz parameter (P2.00) is set to 03.*

### 00: General Purpose

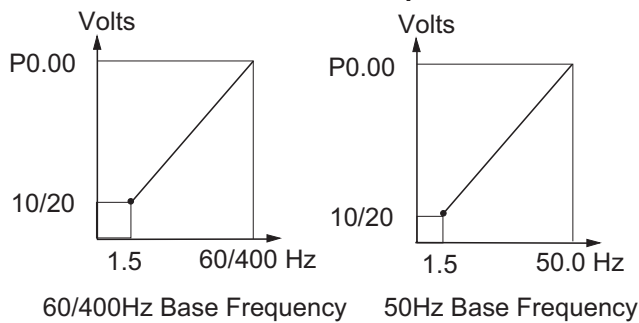

### 03: Custom

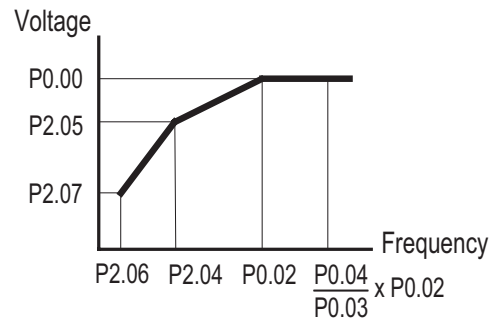

### 01: High Starting Torque

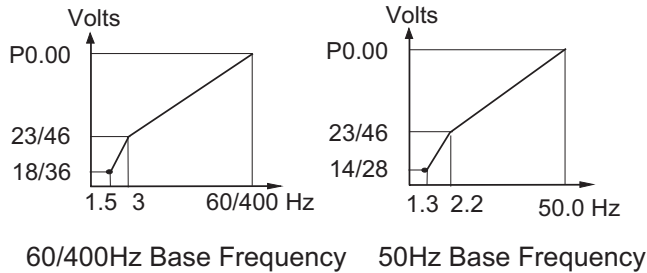

### 02: Fans and Pumps

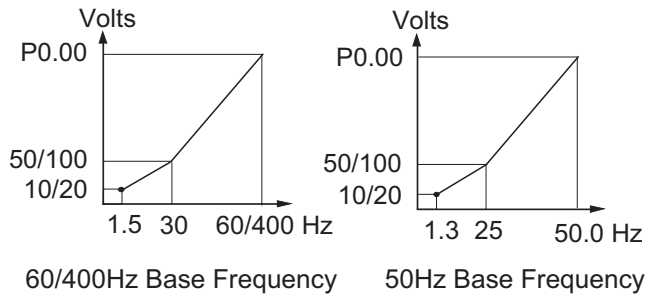

### P2.01 ◆ Slip Compensation

Range: 0.0 to 10.0

Default Setting: 0.0

When controlling an asynchronous induction motor, load on the AC drive will increase causing an increase in slip. This parameter may be used to compensate the nominal slip within a range of 0 to 10. When the output current of the AC drive is greater than the Motor Nameplate Amps (P0.01), the AC drive will adjust its output frequency according to this parameter.

### P2.02 ◆ Auto-torque Boost

Range: 00 to 10

Default Setting: 00

This parameter functions similarly to the P2.00-01 High Starting Torque V/Hz setting, except that this parameter uses less current than does P2.00-01. P2.00-01 boosts starting torque by increasing current at every start beyond what is required to move the load. P2.02 Auto-torque Boost increases the current only as required to move the load. The proper setting for P2.02 is determined by trial and error.



---

*P2.04 through P2.07 are used only when the Volts/Hertz parameter (P2.00) is set to 03.*

---

### P2.04 Mid-point Frequency

Range: 0.1 to 400 Hz

Default Setting: 1.5

This parameter sets the Mid-Point Frequency of V/F curve. With this setting, the V/F ratio between Minimum Frequency and Mid-Point frequency can be determined.

**This parameter must be greater than or equal to the Minimum Output Frequency (P2.06) and less than or equal to the Maximum Voltage Frequency (P0.02). This parameter is used only when the Volts/Hertz parameter (P2.00) is set to 03.**

### P2.05 Mid-point Voltage

Range: 115V/230V: 2.0 to 255V  
460V: 2.0 to 510V  
575V: 2.0 to 637V

Default Setting: 10.0  
20.0  
24.0

This parameter sets the Mid-Point Voltage of any V/F curve. With this setting, the V/F ratio between Minimum Frequency and Mid-Point Frequency can be determined.

**This parameter must be greater than or equal to the Minimum Output Voltage (P2.07) and less than or equal to the Maximum Output Voltage (P0.00). This parameter is used only when the Volts/Hertz parameter (P2.00) is set to 03.**

**P2.06** Minimum Output Frequency

Range: 0.1 to 20.0 Hz

Default Setting: 1.5

This parameter sets the Minimum Output Frequency of the AC drive.

**This parameter must be less than or equal to the Mid-Point Frequency (P2.04).**

**This parameter is used only when the Volts/Hertz parameter (P2.00) is set to 03.**

**P2.07** Minimum Output Voltage

Range: 115V/230V: 2.0 to 50.0V

Default Setting: 10.0

460V: 2.0 to 100.0V

20.0

575V: 2.0 to 130.6V

24.0

This parameter sets the Minimum Output Voltage of the AC drive.

**This parameter must be equal to or less than Mid-Point Voltage (P2.05). This**

**parameter is used only when the Volts/Hertz parameter (P2.00) is set to 03.**

**P2.08** PWM Carrier Frequency

Range: 115V/230V/460V: 01 to 15 kHz

Default Setting: 12

575V: 01 to 10 kHz

6

This parameter sets the carrier frequency of PWM (Pulse-Width Modulated) output.

- In the table below, we see that the carrier frequency of PWM output has a significant influence on the electromagnetic noise, leakage current, heat dissipation of the AC drive and the acoustic noise to the motor:

| Carrier Frequency | Acoustic Noise | Electromagnetic Noise,<br>Leakage Current | Heat Dissipation |
|-------------------|----------------|---|------------------|
| 1kHz              | significant    | minimal                                   | minimal          |
| 15 kHz            | minimal        | moderate                                  | moderate         |

## Digital Parameters

### P3.00 Source of Operation Command

Default Setting: 00

| Settings |  |  |
|----------|--|--|
| 00       | Operation Determined by Digital Keypad                                       |  |
| 01       | Operation determined by external control terminals. Keypad STOP is enabled.  |  |
| 02       | Operation determined by external control terminals. Keypad STOP is disabled. |  |
| 03       | Operation determined by communication interface. Keypad STOP is enabled.     |  |
| 04       | Operation determined by communication interface. Keypad STOP is disabled.    |  |

- This parameter sets the input source for the AC drive operation commands.
- Refer to P3.01 to P3.05 for more details.

### P3.01 Multi-function Input Terminals (DI-DI2)

Default Setting: 00

| Settings |  |  |
|----------|--|--|
| 00       | DI1 - FWD/STOP<br>DI2 - REV/STOP   |  |
| 01       | DI1 - RUN/STOP<br>DI2 - REV/FWD  |  |
| 02       | DI1 - RUN (N.O. latching input)<br>DI2 - REV/FWD<br>DI3 - STOP (N.C. latching input) |  |



*Note: Multi-function Input Terminals DI1 and DI2 do not have separate parameter designations. DI1 and DI2 must be used in conjunction with each other to operate two and three wire control.*

#### P3.01: Setting 00

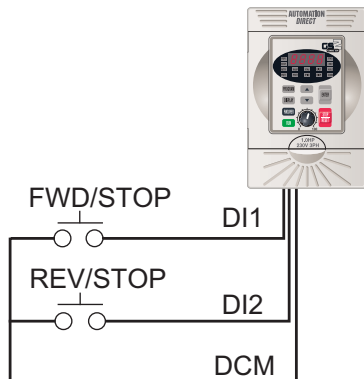

| DI1 | DI2 | Result |
|-----|-----|--------|
| OFF | OFF | STOP   |
| ON  | OFF | FWD    |
| OFF | ON  | REV    |
| ON  | ON  | STOP   |

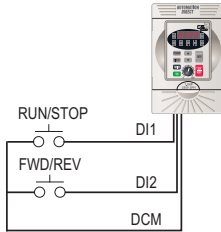

**P3.01: Setting 01**

D11- RUN/STOP select  
 "Open" : Stop  
 "Close" : Run

D12- FWD/REV select  
 "Open" : FWD  
 "Close" : REV

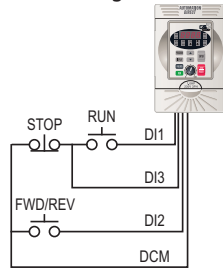
**P3.01: Setting 02**

D11- RUN command  
 Latching input (N.O.)  
 Runs when closed

D12- FWD/REV select  
 "Open" : FWD  
 "Close" : REV

D13- STOP command  
 Latching input (N.C.)  
 Stops when open

|              |                                   |                     |
|--------------|-----------------------------------|---------------------|
| <b>P3.02</b> | <b>Multi-Function Input (DI3)</b> | Default Setting: 00 |
| <b>P3.03</b> | <b>Multi-Function Input (DI4)</b> | Default Setting: 03 |
| <b>P3.04</b> | <b>Multi-function Input (DI5)</b> | Default Setting: 04 |
| <b>P3.05</b> | <b>Multi-function Input (DI6)</b> | Default Setting: 05 |

Settings for P3.02 to P3.05:

|    |  |
|----|--|
| 00 | *External Fault (N.O.)                       |
| 01 | *External Fault (N.C.)                       |
| 02 | External Reset                               |
| 03 | Multi-Speed/PID SP Bit 1                     |
| 04 | Multi-Speed/PID SP Bit 2                     |
| 05 | Multi-Speed/PID SP Bit 3                     |
| 06 | Reserved                                     |
| 07 | Reserved                                     |
| 08 | Reserved                                     |
| 09 | Jog  |
| 10 | External Base Block (N.O.)                   |
| 11 | External Base Block (N.C.)                   |
| 12 | Second Accel/Decel Time                      |
| 13 | Speed Hold                                   |
| 14 | Increase Speed (P4.00 must be set to 1)      |
| 15 | Decrease Speed (P4.00 must be set to 1)      |
| 16 | Reset Speed to Zero (P4.00 must be set to 1) |
| 17 | PID Disable (N.O.)                           |
| 18 | PID Disable (N.C.)                           |
| 99 | Input Disable                                |

\* Use either 00 or 01, but not both. Use interposing relays if more contacts are needed.

## Setting Explanations for parameters P3.02 - P3.05

### Setting 00: External Fault (N.O.)

When an External Fault input signal is received, the AC drive output will turn off, the drive will display "EF" on the LED Display, and the motor will Coast to Stop. To resume normal operation, the external fault must be cleared, and the drive must be reset.

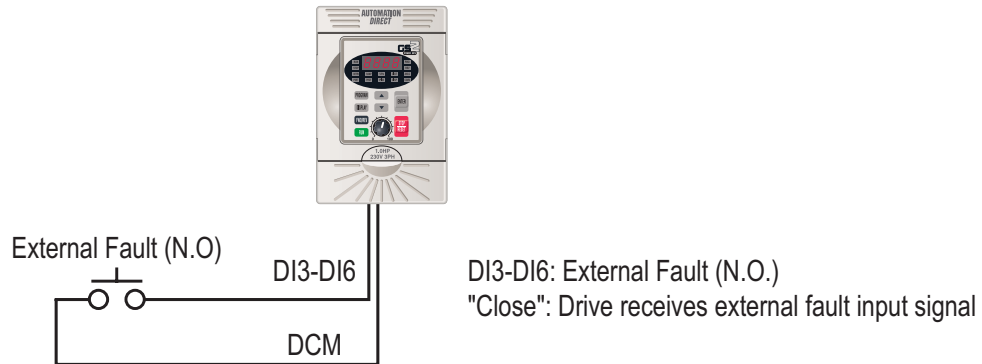

### Setting 01: External Fault (N.C.)

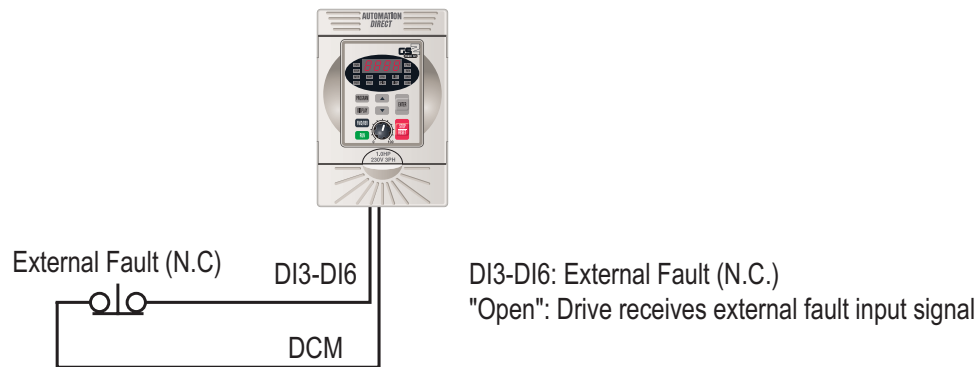

### Setting 02: External Reset

An External Reset has the same function as the Reset key on the digital keypad. Use an External Reset to reset the drive after a fault.

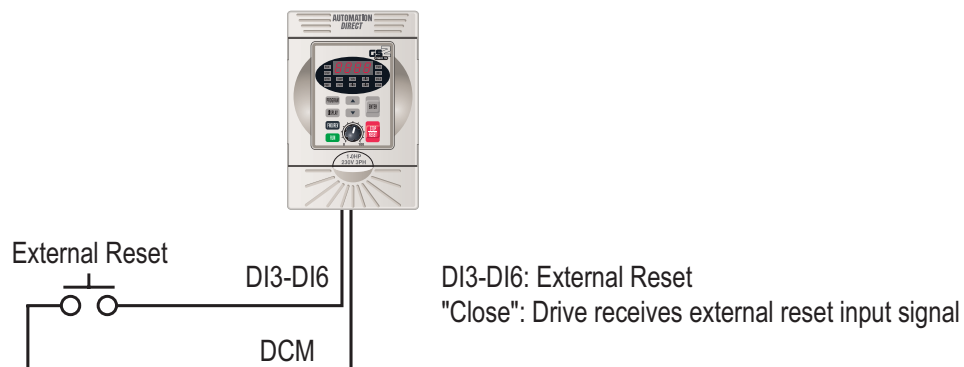

**Settings 03, 04, and 05: Multi-Speed/PID SP Bits 1, 2, and 3**

If PID operation is inhibited (P7.00 = 00), the three Multi-Speed/PID SP Bits are used to select the multi-speed settings defined by P5.01 to P5.07. If PID operation is enabled (P7.00 ≠ 00), the three Multi-Speed/PID SP Bits are used to select the PID multi-setpoint settings defined by P7.11 to P7.17.

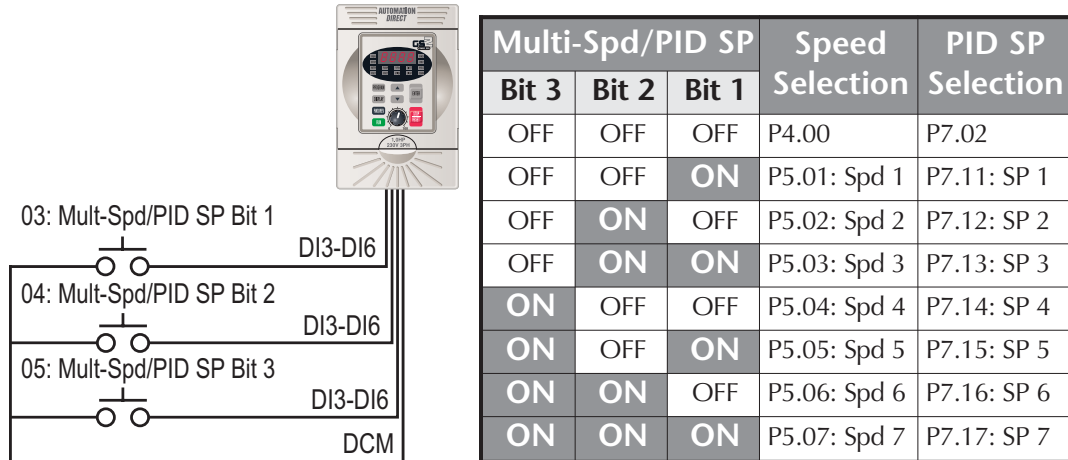

Note: In order to use the Multi-Speed settings, parameters 5.01 to 5.07 must be set. In order to use the Multi-PID SP settings, parameters 7.11 to 7.17 must be set.



Note: When all multi-speed inputs are off, the AC drive reverts back to the Source of Frequency Command (P4.00), or the PID Setpoint Source (P7.02).

**Setting 09: Jog Command**

This setting configures a Multi-function Input Terminal to give the Jog Command when activated. P5.00 sets the Jog Speed.

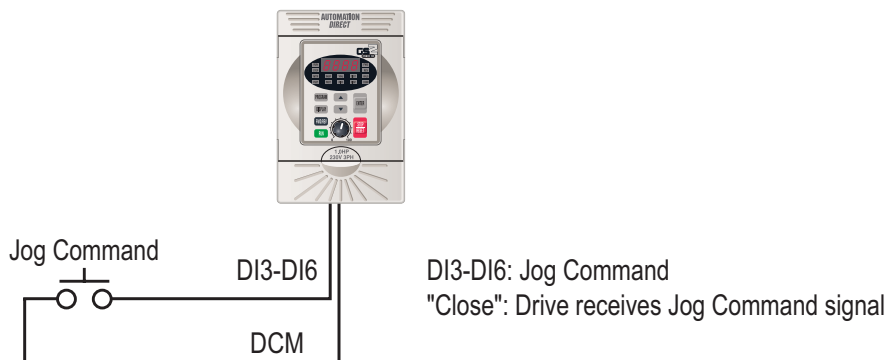

Note: The motor must be stopped to initiate this command. The Jog Command cannot be used simultaneously with an active FWD/STOP, REV/STOP, or RUN/STOP command. The Jog Command can be used with an active REV/FWD command.

**Settings 10 and 11: External Base Block (N.O.) and External Base Block (N.C.)**

Value 10 is for a normally open (N.O) input and value 11 is for a normally closed (N.C.) input.

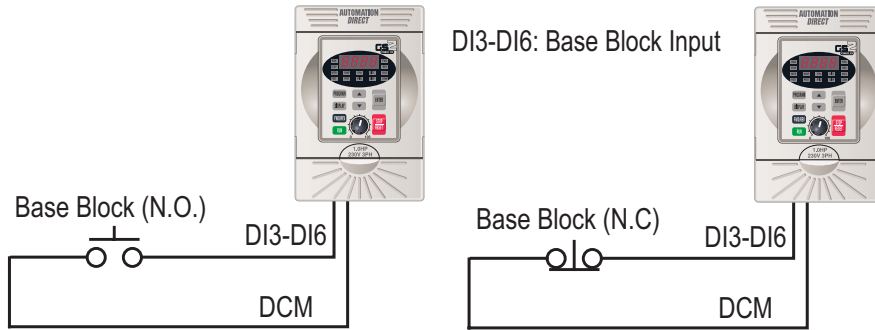

When an External Base Block is activated, the LED display shows *bb*, the AC drive stops all output, and the motor will free run. When the External Base Block is deactivated, the AC drive will start the speed search function and synchronize with the motor speed. The AC drive will then accelerate to the Master Frequency.

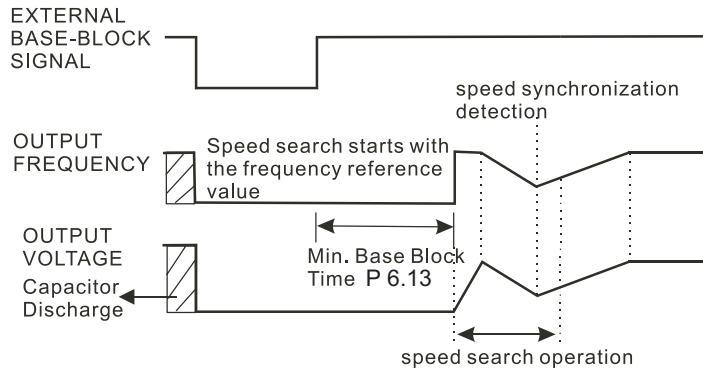

**Setting 12: Second Accel/Decel Time**

Multi-function Input Terminals DI3-DI6 can be set to select between Accel/Decel times 1 and 2. Parameters P1.01 and P1.02 set Accel 1 and Decel 1 times. Parameters P1.05 and P1.06 set Accel 2 and Decel 2 times.

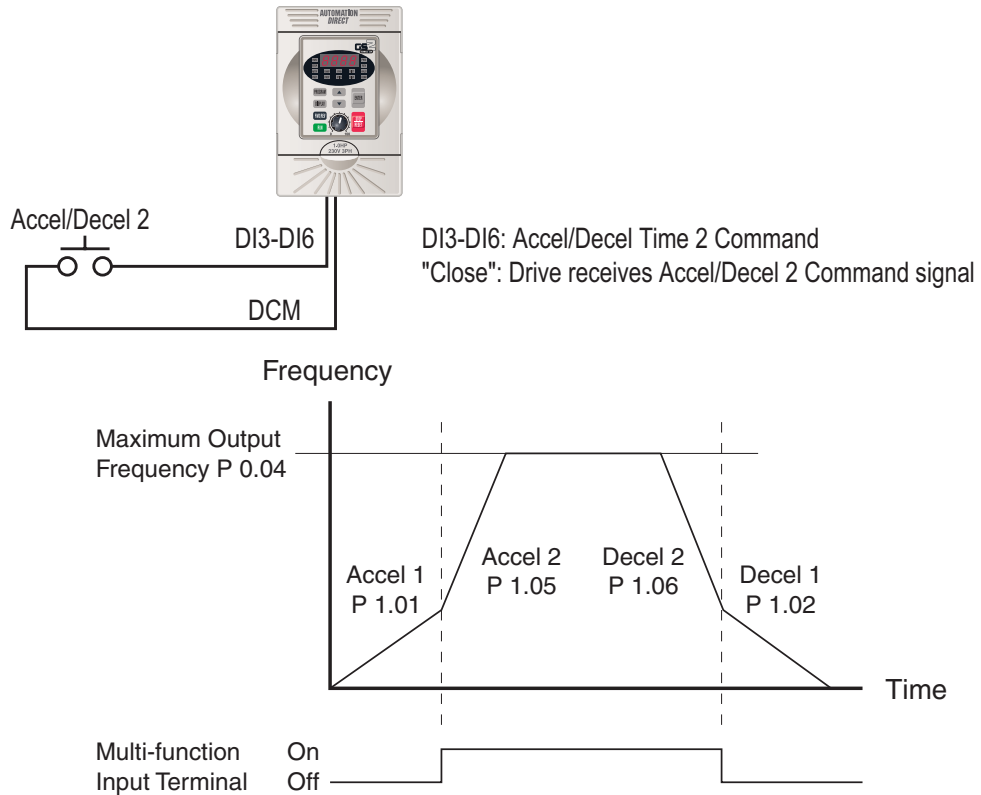

**Setting 13: Speed Hold**

When the Speed Hold command is received, the drive acceleration or deceleration is stopped and the drive maintains a constant speed.

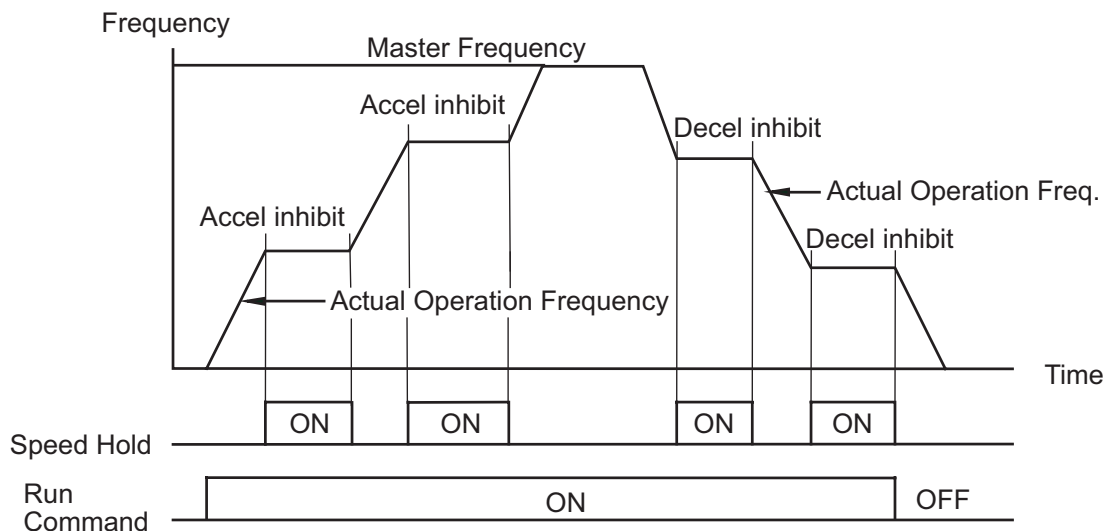

**Settings 14 and 15: Increase and Decrease Speed  
(Electronic Motor Operated Potentiometer)**

Settings 14 and 15 allow the Multi-function terminals to be used to increase or decrease speed. As long as the DI terminal is activated, the speed reference will continuously increase or decrease according to the acceleration and deceleration ramp settings.

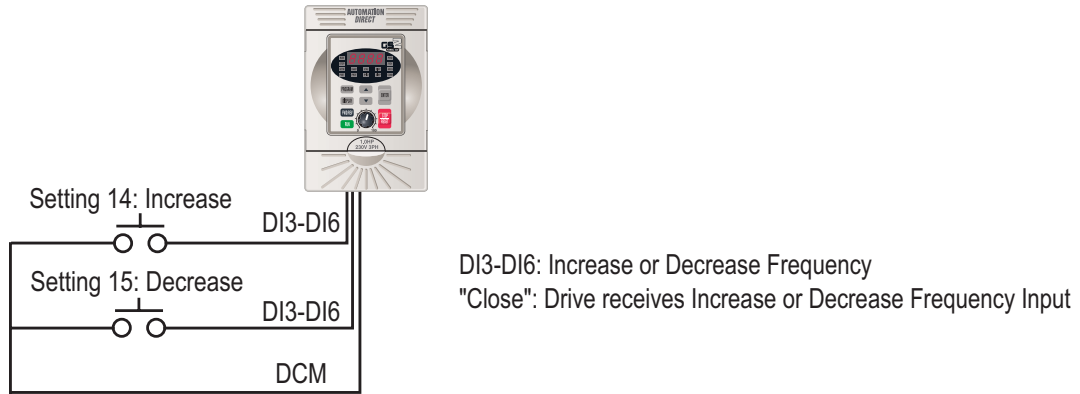

*Note: In order to use these settings, P4.00 must be set to 01.*

**Setting 16: Reset Speed to Zero**

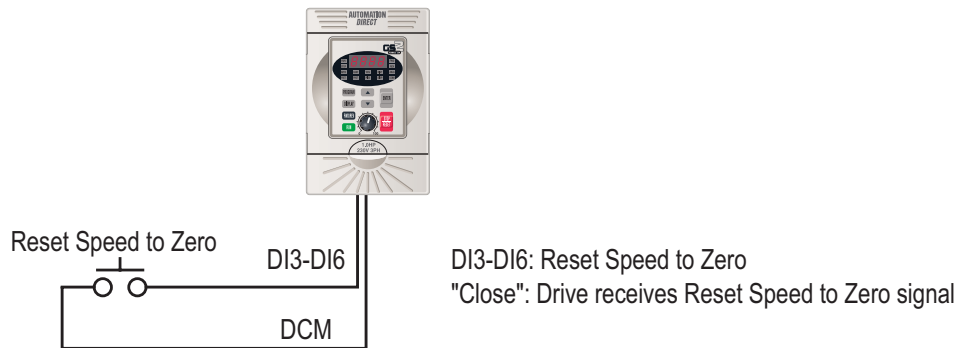

**Settings 17 and 18: PID Disable (N.O) and (N.C.)**

Settings 17 and 18 set the Multi-function terminals to disable PID operation.

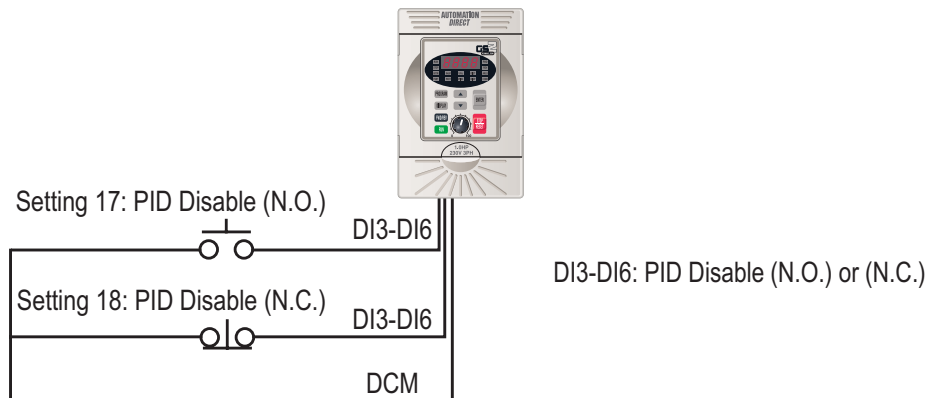

### Setting 99: Multi-Function Input Disable

Setting a Multi-Function Input to 99 will disable that input. The purpose of this function is to provide isolation for unused Multi-Function Input Terminals. Any unused terminals should be programmed to 99 to make sure they have no effect on drive operation.



---

*Note: Any **unused terminals** should be programmed to **99** to make sure they have no effect on drive operation.*

---

### P3.11 Multi-function Output Terminal 1

Default Setting: 00

### P3.12 Multi-function Output Terminal 2

Default Setting: 01

Settings for P3.11 to P3.12:

|           |    |                                       |
|-----------|----|---------------------------------------|
| Settings: | 00 | AC Drive Running                      |
|           | 01 | AC Drive Fault                        |
|           | 02 | At Speed                              |
|           | 03 | Zero Speed                            |
|           | 04 | Above Desired Frequency (P3.16)       |
|           | 05 | Below Desired Frequency (P3.16)       |
|           | 06 | At Maximum Speed (P0.02)              |
|           | 07 | Over Torque Detected                  |
|           | 08 | Above Desired Current (P3.17)         |
|           | 09 | Below Desired Current (P3.17)         |
|           | 10 | PID Deviation Alarm (P3.18 and P3.19) |

#### Setting Function Explanations:

- 00: AC Drive Running—The terminal will be activated when there is an output from the drive.
- 01: AC Drive Fault—The terminal will be activated when one of the faults listed under parameters P6.31 through P6.36 occurs.
- 02: At Speed—The terminal will be activated when the AC drive attains the Command Frequency (P4.00 or P5.01~P5.07).
- 03: Zero Speed—The output will be activated when Command Frequency (P4.00 or P5.01~P5.07) is lower than the Minimum Output Frequency (P2.06).
- 04: Above Desired Frequency—The output will be activated when the AC drive is above the Desired Frequency (P3.16).
- 05: Below Desired Frequency—The output will be activated when the AC drive is below the Desired Frequency (P3.16).
- 06: At Maximum Speed—The output will be activated when the AC drive reaches Motor Maximum RPM (P0.04).
- 07: Over Torque Detected—The output will be activated when the AC drive reaches the Over-torque Detection Level (P6.08), and exceeds this level for a time greater than the Over-torque Detection Time (P6.09).
- 08: Above Desired Current—The output will be activated when the AC drive is above the Desired Current (P3.17).
- 09: Below Desired Current—The output will be activated when the AC drive is below the Desired Current (P3.17).
- 10: PID Deviation Alarm—The output will be activated when the AC drive exceeds the PID Deviation Level (P3.18) for longer than the PID Deviation Time (P3.19).



**P3.16** ◆ **Desired Frequency**

Range: 0.0 to 400.0 Hz

Default Setting: 0.0

- If a Multi-function output terminal is set to function as Desired Frequency Attained (P3.11 or P3.12 = 04 or 05), then the output will be activated when the programmed frequency is attained.

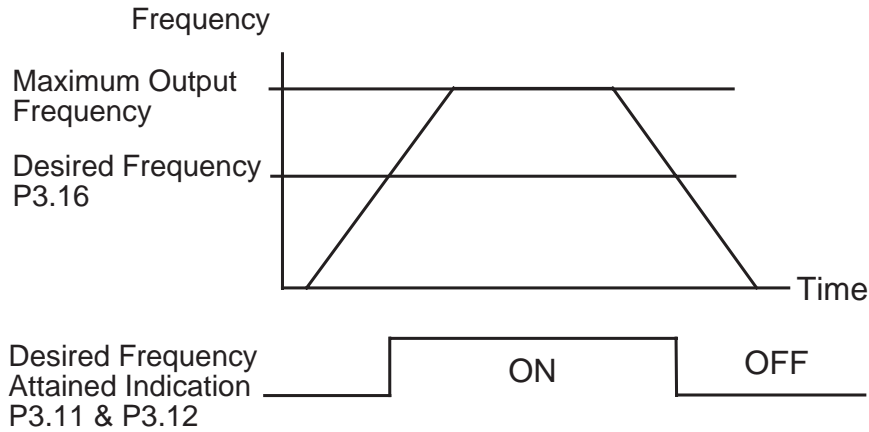

**P3.17** ◆ **Desired Current**

Range: 0.0 to <Drive Rated Amps>

Default Setting: 0.0

**P3.18** ◆ **PID Deviation Level**

Range: 1.0 to 50.0%

Default Setting: 10.0

**P3.19** ◆ **PID Deviation Time**

Range: 0.1 to 300.0 sec

Default Setting: 5.0

# Analog Parameters

## P4.00 Source of Frequency Command

Default: 00

- Settings:
- 00 Frequency determined by keypad potentiometer
  - 01 Frequency determined by digital keypad up/down
  - 02 Frequency determined by 0 to +10V input (including remote potentiometer) on AI terminal. Switch SW1 must be set to AVI.



Switch SW1 must be set to AVI in order to use a 0 to +10V input

- 03 Frequency determined by 4 to 20mA input on AI terminal. Switch SW1 must be set to ACI.



Switch SW1 must be set to ACI in order to use a 4 to 20mA input

- 04 Frequency determined by 0 to 20mA input on AI terminal. Switch SW1 must be set to ACI.



Switch SW1 must be set to ACI in order to use a 0 to 20mA input

- 05 Frequency determined by RS-232/RS-485 communication interface. Switches SW2 and SW3 must be set to RS-232 or RS-485.

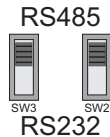

RS-232 / RS-485 communication is determined by switches SW2 & SW3

## P4.01 Analog Input Offset Polarity

- Range:
- 00 Offset disabled
  - 01 Positive Offset
  - 02 Negative Offset

Default Setting: 00

- This parameter sets the potentiometer Bias Frequency to be positive or negative.
- The Analog Input Offset calculation will also define the Offset Polarity. See the note after P4.02.

**P4.02** ◆ Analog Input Offset

Range: 0.0 to 100%

Default Setting: 0.0

This parameter can be set during the operation

- This parameter provides a frequency offset for an analog input.
- Use the equation below to determine the Analog Input Offset. For this equation, you will need to know the necessary Minimum Frequency References and Maximum Output Frequency needed for your application.

$$\text{Analog Offset \%} = \left( \frac{\text{Min. Frequency Reference}}{\text{Max. Frequency Reference}} \right) \times 100$$



*Note: The result of the Analog Input Offset calculation will also define the Analog Input Offset Polarity (P4.01). A positive answer means you should have a positive offset. A negative answer means you should have a negative offset.*

**P4.03** ◆ Analog Input Gain

Range: 0.0 to 300.0%

Default Setting: 100.0

This parameter can be set during the operation

- This parameter sets the ratio of analog input vs frequency output.
- Use the equation below to calculate the Analog Input Gain. For this equation, you will need to know the minimum and maximum set-point frequencies needed for your application.

$$\text{Analog Gain \%} = \left( \frac{\text{Max. Frequency Reference} - \text{Min. Frequency Reference}}{\text{Maximum Output Frequency}} \right) \times 100$$

**P4.04** Analog Input Reverse Motion Enable

Range: 00 Forward Motion Only

Default Setting: 00

01 Reverse Motion Enable

- P4.01 to P4.04 are used when the source of frequency command is the analog signal (0 to +10 VDC, 0 to 20 mADC, or 4 to 20 mADC). Refer to the following examples:

### Analog Input Examples

Use the equations below when calculating the values for the Maximum Output Frequency, Analog Input Offset, Analog Input Gain, and the Mid-point Frequency.

$$\text{A) Max. Output Frequency} = \left( \frac{\text{Motor Max. RPM (P0-04)}}{\text{Motor Base RPM (P0-03)}} \right) \times \text{Base Frequency (P0-02)}$$



---

*Note: The Maximum Output Frequency is not a parameter setting, but is needed in order to calculate the Analog Gain. The default Maximum Output Frequency for the GS2 drive is 60Hz. If parameters P0.02, P0.03, or P0.04 are changed, then the Maximum Output Frequency will change.*

---

$$\text{B) Analog Offset \%} = \left( \frac{\text{Min. Frequency Reference}}{\text{Max. Frequency Reference}} \right) \times 100$$

$$\text{C) Analog Gain \%} = \left( \frac{\text{Max. Frequency Reference} - \text{Min. Frequency Reference}}{\text{Maximum Output Frequency}} \right) \times 100$$

$$\text{D) Mid-point Freq.} = \left( \frac{\text{Max. Freq. Reference} - \text{Min. Freq. Reference}}{2} \right) + \text{Min. Freq. Reference}$$



---

*Note: The Mid-point Frequency calculation shows the frequency reference of the drive when the potentiometer or other analog device is at its mid-point.*

---

### Example 1: Standard Operation

This example illustrates the default operation of the drive. The example is given to further illustrate the use of the analog calculations. The full range of the analog input signal corresponds to the full forward frequency range of the AC drive.

- Minimum Frequency Reference = 0Hz
- Maximum Frequency Reference = 60Hz

#### Calculations

A) **Max. Output Frequency** =  $\left(\frac{1750 \text{ RPM}}{1750 \text{ RPM}}\right) \times 60\text{Hz} = 60\text{Hz}$

B) **Analog Offset %** =  $\left(\frac{0\text{Hz}}{60\text{Hz}}\right) \times 100 = 0\%$

C) **Analog Gain %** =  $\left(\frac{60\text{Hz} - 0\text{Hz}}{60\text{Hz}}\right) \times 100 = 100\%$

D) **Mid-point Frequency** =  $\left(\frac{60\text{Hz} - 0\text{Hz}}{2}\right) + 0\text{Hz} = 30\text{Hz}$

#### Parameter Settings

- P4.01: 01 – Positive Input Offset Polarity  
 P4.02: 00 – 0% Analog Input Offset  
 P4.03: 100 – 100% Analog Input Gain  
 P4.04: 00 – Forward Motion Only

#### Results

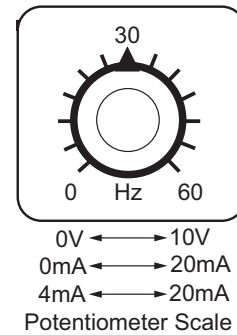
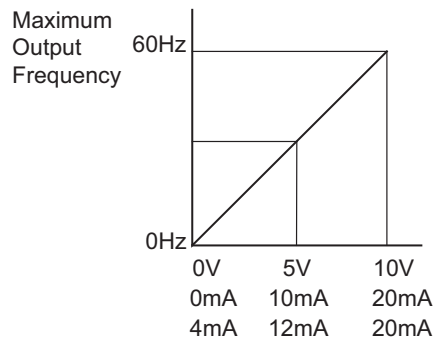

### Example 2: Positive Offset

In this example, the Analog Input will have a positive offset while still using the full scale of the potentiometer. When the potentiometer is at its lowest value (0V, 0mA, or 4mA), the set-point frequency will be at 10Hz. When the potentiometer is at its maximum value (10V or 20mA), the set-point frequency will be at 60Hz.

- Minimum Frequency Reference = 10Hz
- Maximum Frequency Reference = 60Hz

#### Calculations

$$A) \text{ Max. Output Frequency} = \left( \frac{1750 \text{ RPM}}{1750 \text{ RPM}} \right) \times 60\text{Hz} = 60\text{Hz}$$

$$B) \text{ Analog Offset \%} = \left( \frac{10\text{Hz}}{60\text{Hz}} \right) \times 100 = 16.7\%$$

$$C) \text{ Analog Gain \%} = \left( \frac{60\text{Hz} - 10\text{Hz}}{60\text{Hz}} \right) \times 100 = 83.3\%$$

$$D) \text{ Mid-point Frequency} = \left( \frac{60\text{Hz} - 10\text{Hz}}{2} \right) + 10\text{Hz} = 35\text{Hz}$$

#### Parameter Settings

P4.01: 01 – Positive Input Offset Polarity  
 P4.02: 16.7 – 16.7% Analog Input Offset  
 P4.03: 83.3 – 83.3% Analog Input Gain  
 P4.04: 00 – Forward Motion Only

#### Results

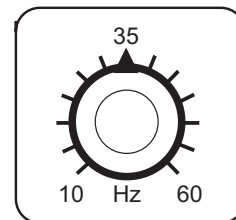
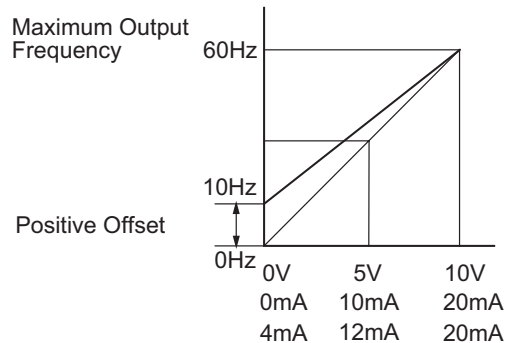

0V ←→ 10V  
 0mA ←→ 20mA  
 4mA ←→ 20mA  
 Potentiometer Scale

### Example 3: Forward and Reverse Operation

In this example, the potentiometer is programmed to run a motor full-speed in both forward and reverse direction. The frequency reference will be 0Hz when the potentiometer is positioned at mid-point of its scale. Parameter P4.04 must be set to enable reverse motion.



*Note: When calculating the values for the Analog Input using reverse motion, the reverse frequency reference should be shown using a negative (-) number. Pay special attention to signs (+/-) for values representing reverse motion.*

- Minimum Frequency Reference = -60Hz (reverse)
- Maximum Frequency Reference = 60Hz

#### Calculations

A) **Max. Output Frequency** =  $\left(\frac{1750 \text{ RPM}}{1750 \text{ RPM}}\right) \times 60\text{Hz} = 60\text{Hz}$

B) **Analog Offset %** =  $\left(\frac{-60\text{Hz}}{60\text{Hz}}\right) \times 100 = -100\%$



*Note: The negative (-) value for the Analog Offset % shows that a negative offset is needed for P4.01.*

C) **Analog Gain %** =  $\left(\frac{60\text{Hz} - (-60\text{Hz})}{60\text{Hz}}\right) \times 100 = 200\%$

D) **Mid-point Frequency** =  $\left(\frac{60\text{Hz} - (-60\text{Hz})}{2}\right) + (-60\text{Hz}) = 0\text{Hz}$

#### Parameter Settings

- P4.01: 02 – Negative Input Offset Polarity
- P4.02: 100 – 100% Analog Input Offset
- P4.03: 200 – 200% Analog Input Gain
- P4.04: 01 – Reverse Motion Enable

#### Results

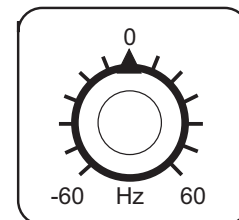
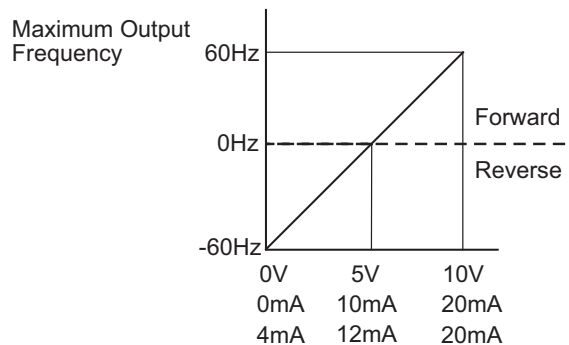

0V ↔ 10V  
 0mA ↔ 20mA  
 4mA ↔ 20mA  
 Potentiometer Scale

### Example 4: Forward Run/Reverse Jog

This example shows an application in which the drive runs full-speed forward and jogs in reverse. The full scale of the potentiometer will be used.



*Note: When calculating the values for the Analog Input using reverse motion, the reverse frequency reference should be shown using a negative (-) number. Pay special attention to signs (+/-) for values representing reverse motion.*

- Minimum Frequency Reference = -15Hz (reverse)
- Maximum Frequency Reference = 60Hz

#### Calculations

$$\text{A) Max. Output Frequency} = \left( \frac{1750 \text{ RPM}}{1750 \text{ RPM}} \right) \times 60\text{Hz} = 60\text{Hz}$$

$$\text{B) Analog Offset \%} = \left( \frac{-15\text{Hz}}{60\text{Hz}} \right) \times 100 = -25\%$$



*Note: The negative (-) value for the Analog Offset % shows that a negative offset is needed for P4.01.*

$$\text{C) Analog Gain \%} = \left( \frac{60\text{Hz} - (-15\text{Hz})}{60\text{Hz}} \right) \times 100 = 125\%$$

$$\text{D) Mid-point Frequency} = \left( \frac{60\text{Hz} - (-15\text{Hz})}{2} \right) + (-15\text{Hz}) = 22.5\text{Hz}$$

#### Parameter Settings

- P4.01: 02 – Negative Input Offset Polarity
- P4.02: 25 – 25% Analog Input Offset
- P4.03: 125 – 125% Analog Input Gain
- P4.04: 01 – Reverse Motion Enable

#### Results

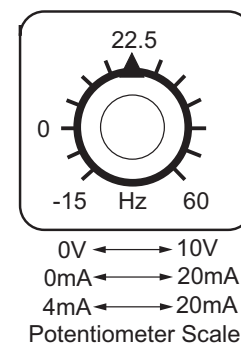
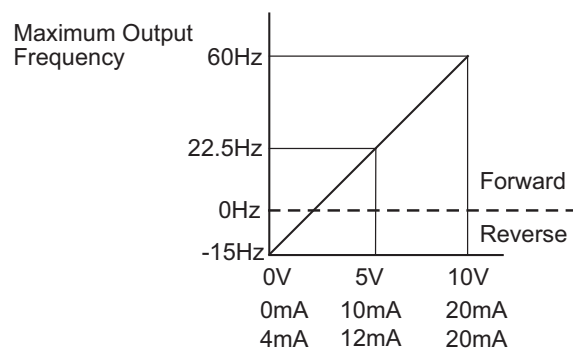



### Example 5: Reduced Analog Gain and Increased Maximum Output Frequency

This example illustrates two separate features:

- 1) limiting the Maximum Frequency Reference by reducing the Analog Input Gain
- 2) increasing the Maximum Output Frequency to run the motor faster than the Motor Base RPM

When the Analog Input is at its maximum value (10V or 20mA), the set-point frequency will be 50Hz. However, the Jog and Multi-speed settings can set the output as high as 70Hz.

- Minimum Frequency Reference = 0Hz
- Maximum Frequency Reference = 50 Hz
- Motor Maximum RPM = 2042 rpm



**WARNING: The Motor Maximum RPM parameter (P0.04) should never exceed the maximum speed rating for the motor you are using. If this information is not readily available, consult your motor manufacturer.**

#### Calculations

$$A) \text{ Max. Output Frequency} = \left( \frac{2042 \text{ RPM}}{1750 \text{ RPM}} \right) \times 60\text{Hz} = 70\text{Hz}$$

$$B) \text{ Analog Offset \%} = \left( \frac{0\text{Hz}}{50\text{Hz}} \right) \times 100 = 0\%$$

$$C) \text{ Analog Gain \%} = \left( \frac{50\text{Hz} - (0\text{Hz})}{70\text{Hz}} \right) \times 100 = 71.4\%$$

$$D) \text{ Mid-point Frequency} = \left( \frac{50\text{Hz} - (0\text{Hz})}{2} \right) + (0\text{Hz}) = 25\text{Hz}$$

#### Parameter Settings

- P0.04: 2042 – Motor Maximum RPM
- P4.01: 00 – Offset disabled
- P4.02: 00 – 0% Analog Input Offset
- P4.03: 71.4 – 71.4% Analog Input Gain
- P4.04: 00 – Forward Motion Only

#### Results

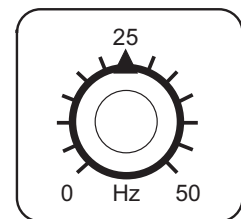
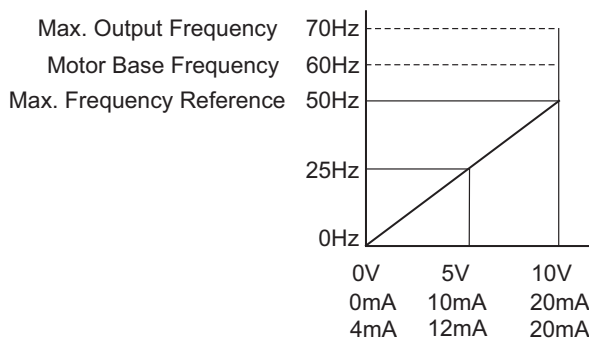

0V ←→ 10V  
 0mA ←→ 20mA  
 4mA ←→ 20mA  
 Potentiometer Scale

### P4.05 Loss of ACI Signal (4-20mA)

Settings: 00 - Decelerate to 0Hz Default Setting: 00  
 01 - Stop immediately and display "EF".  
 02 - Continue operation by the last frequency command

This parameter determines the operation of the drive when the ACI frequency command is lost.

### P4.11 Analog Output Signal

Range: 00 - Frequency Hz Default Setting: 00  
 01 - Current A  
 02 - PV

This parameter selects either Output Frequency or current to be displayed using the 0 to 10V A0 output.

### P4.12 Analog Output Gain

Range: 00 to 200% Default Setting: 100

This parameter sets the voltage range of the analog output signal, on output terminal A0.

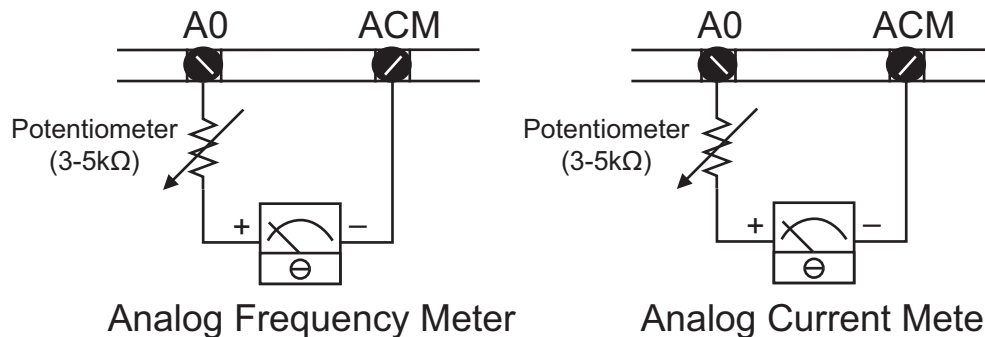

- The analog output voltage is directly proportional to the output frequency of the AC drive. With the factory setting of 100%, the Maximum Output Frequency of the AC drive corresponds to +10VDC analog voltage output. (The actual voltage is about +10VDC, and can be adjusted by P4.12)
- The analog output voltage is directly proportional to the output current of the AC drive. With the factory setting of 100%, the 2.5 times rated current of the AC drive corresponds to +10 VDC analog voltage output. (The actual voltage is about +10 VDC, and can be adjusted by P4.12).

Note: Any type of voltmeter can be used. If the meter reads full scale at a voltage less than 10 volts, then P4.12 should be set by the following formula:

$$\mathbf{P4.12 = (meter\ full\ scale\ voltage \div 10) \times 100\%}$$

For Example: When using the meter with full scale of 5 Volts, adjust P4.12 to 50%.

## Preset Parameters

### P5.00 ◆ Jog

Range: 0.0 to 400.0 Hz

Default Setting: 6.0

The Jog Command is selected by a Multi-Function Input Terminal (P3.02 to P3.05) set to the Jog Function (09).

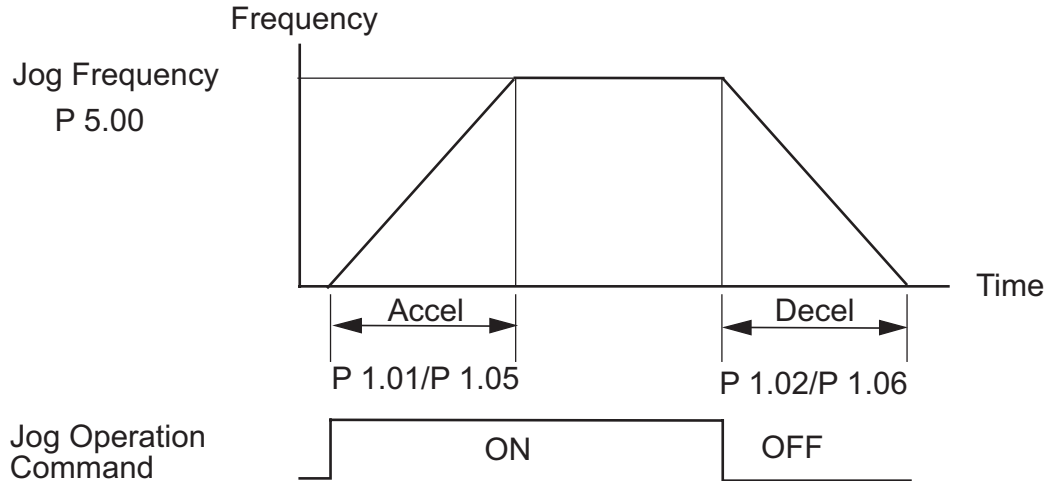

**P5.01** ◆ Multi-Speed 1

**P5.02** ◆ Multi-Speed 2

**P5.03** ◆ Multi-Speed 3

**P5.04** ◆ Multi-Speed 4

**P5.05** ◆ Multi-Speed 5

**P5.06** ◆ Multi-Speed 6

**P5.07** ◆ Multi-Speed 7

Range for P5.01 - P5.07: 0.0 to 400.0 Hz

Default Setting: 0.0

- The Multi-Function Input Terminals (refer to P3.01 to P3.05) are used to select one of the AC drive Multi-Step speeds. The speeds (frequencies) are determined by P5.01 to P5.07 shown above.

| Multi-Speed Bits |       |       | Speed Selection            |
|------------------|-------|-------|----------------------------|
| Bit 3            | Bit 2 | Bit 1 |                            |
| OFF              | OFF   | OFF   | P4.00: Source of Frequency |
| OFF              | OFF   | ON    | P5.01: Multi-Speed 1       |
| OFF              | ON    | OFF   | P5.02: Multi-Speed 2       |
| OFF              | ON    | ON    | P5.03: Multi-Speed 3       |
| ON               | OFF   | OFF   | P5.04: Multi-Speed 4       |
| ON               | OFF   | ON    | P5.05: Multi-Speed 5       |
| ON               | ON    | OFF   | P5.06: Multi-Speed 6       |
| ON               | ON    | ON    | P5.07: Multi-Speed 7       |



*Note: When all multi-speed inputs are off, the AC drive reverts back to the Command Frequency (P4.00).*

## Protection Parameters

### P6.00 Electronic Thermal Overload Relay

Default Setting: 00

Settings:

00 Constant Torque (inverter/vector duty motors)

Use this setting when using the drives with motors designed specifically for AC drive outputs and for running at low speeds with high currents. Motor currents will be 100% throughout the speed range, and can be up to 150% for one minute.

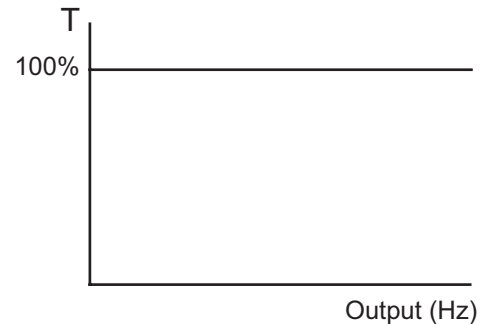

01 Variable Torque (fan cooled standard motors)

Use this setting when using the drives with motors which are NOT designed specifically for AC drive outputs. Motors with shaft mounted fans offer poor cooling at low speeds, therefore the output can be derated at lower output frequencies. This derated current is for protecting the motor at lower speeds.

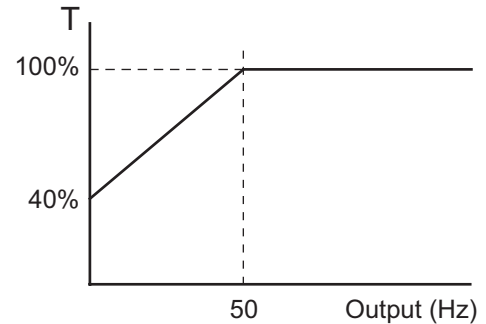

The output current is derated as follows:

- $I_{\text{output}} (\%) = [ f_{\text{output}} (\text{Hz}) \times 1.2 \text{ \%/Hz} ] + 40\%$

Example:

If the rated motor current is 10A, and the output frequency is 25Hz, the derating will be 70%, and the overload will be 10.5A (150%) for one minute.

- $I_{\text{output}} (\%) = [ (25\text{Hz}) (1.2 \text{ \%/Hz}) ] + 40\% = 70\%$

- $10\text{A} \times 70\% = 7\text{A}$

- $7\text{A} \times 150\% = 10.5\text{A}$

02 Inactive

### P6.01 Auto Restart After Fault

Range: 00 to 10

Default Setting: 00

- After fault occurs (allowable faults: over-current OC, over-voltage OV), the AC drive can be reset/restarted automatically up to 10 times. Setting this parameter to 0 will disable the reset/restart operation after any fault has occurred. When enabled, the AC drive will restart with speed search, which starts at the previous Frequency. To set the fault recovery time after a fault, please see (P6.13) base-block time for speed search.

### P6.02 Momentary Power Loss

Default Setting: 00

|           |    |   |
|-----------|----|---|
| Settings: | 00 | Stop operation after momentary power loss.  |
|           | 01 | Continue operation after momentary power loss, speed search from Speed Reference. |
|           | 02 | Continue operation after momentary power loss, speed search from Minimum Speed.   |



*Note: Also refer to P6.30, Line Start Lockout.*

*Note: This parameter (P6.02) will work only if the Source of Operation (P3.00) is set to something other than 00 (Operation determined by digital keypad).*

### P6.03 Reverse Operation Inhibit

Default Setting: 00

|           |    |                           |
|-----------|----|---------------------------|
| Settings: | 00 | Enable Reverse Operation  |
|           | 01 | Disable Reverse Operation |

This parameter determines whether the AC Motor Drive can operate in the reverse direction.

**P6.04 Auto Voltage Regulation**

Default Setting: 00

- Settings:
- 00 AVR enabled
  - 01 AVR disabled
  - 02 AVR disabled during decel
  - 03 AVR disabled during Stop

- AVR function automatically regulates the AC drive output voltage to the Maximum Output Voltage (P0.00). For instance, if P0.00 is set at 200 VAC and the input voltage is at 200V to 264 VAC, then the Maximum Output Voltage will automatically be regulated to 200 VAC.
- Without AVR function, the Maximum Output Voltage may vary between 180V to 264 VAC, due to the input voltage varying between 180V to 264 VAC.
- Selecting program value 2 enables the AVR function and also disables the AVR function during deceleration. This offers a quicker deceleration.

**P6.05 Over-Voltage Stall Prevention**

- Range: 00 Enable Over-voltage Stall Prevention  
 01 Disable Over-voltage Stall Prevention

Default Setting: 00

- During deceleration, the AC drive DC bus voltage may exceed its Maximum Allowable Value due to motor regeneration. When this function is enabled, the AC drive will stop decelerating, and maintain a constant output frequency. The drive will resume deceleration when the voltage drops below the factory-preset value.

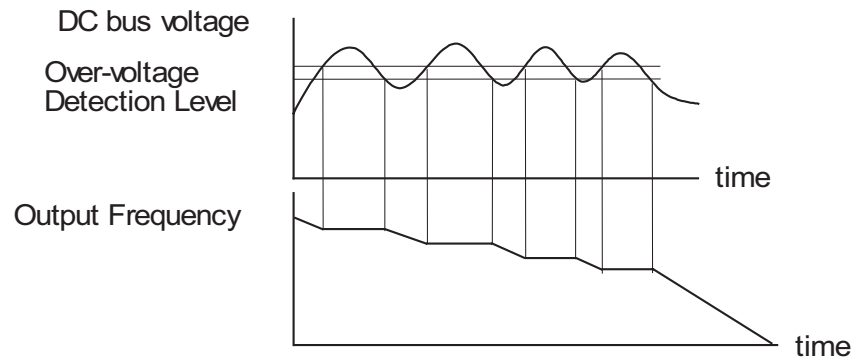

*Note: With moderate inertial loads, over-voltage during deceleration will not occur. For applications with high inertia loads, the AC drive will automatically extend the deceleration time. If deceleration time is critical for the application, a dynamic braking resistor should be used. Set this parameter to 01 (disable) when using a dynamic braking resistor.*

### P6.06 Auto Adjustable Accel/Decel

Default Setting: 00

|           |    |                                   |
|-----------|----|-----------------------------------|
| Settings: | 00 | Linear Accel/Decel                |
|           | 01 | Auto Accel, Linear Decel          |
|           | 02 | Linear Accel, Auto Decel          |
|           | 03 | Auto Accel/Decel                  |
|           | 04 | Auto Accel/Decel Stall Prevention |

If the auto accel/decel is selected, the AC drive will accel/decel in the fastest and smoothest means possible by automatically adjusting the time of accel/decel.

This parameter provides five modes to choose:

- 00 Linear Acceleration and deceleration (operation by P1.01, P1.02 or P1.05, P1.06 acceleration/deceleration time).
- 01 Automatic acceleration, linear deceleration (Operation by automatic acceleration time, P1.02 or P1.06 deceleration time).
- 02 Linear acceleration and automatic deceleration (Operation by automatic acceleration time, P1.01 or P1.05 acceleration time).
- 03 Automatic acceleration, deceleration (Operation by AC drive auto adjustable control).
- 04 Auto acceleration, deceleration. The auto accel/decel will not be quicker than the settings for acceleration (P1.01 or P1.05) or deceleration (P1.02 or P1.06). The operation is specific to preventing a stall.

### P6.07 Over-Torque Detection Mode

Default Setting: 00

|           |    |   |
|-----------|----|---|
| Settings: | 00 | Disabled                                |
|           | 01 | Enabled during constant speed operation |
|           | 02 | Enabled during acceleration             |

### P6.08 Over-Torque Detection Level

Range: 30 to 200%

Default Setting: 150

- A setting of 100% is proportional to the Rated Output Current of the drive.
- This parameter sets the Over-Torque Detection level in 1% increments. (The AC drive rated current is equal to 100%.)

### P6.09 Over-Torque Detection Time

Range: 0.1 to 10.0

Default Setting: 0.1

This parameter sets the Over-Torque Detection Time in units of 0.1 seconds.



**P6.10 Over-Current Stall Prevention During Acceleration**

Range: 20 to 200%

Default Setting: 150

A setting of 100% is equal to the Rated Output Current of the drive.

- Under certain conditions, the AC drive output current may increase abruptly, and exceed the value specified by P6.10. This is commonly caused by rapid acceleration or excessive load on the motor. When this function is enabled, the AC drive will stop accelerating and maintain a constant output frequency. The AC drive will only resume acceleration when the current drops below the maximum value.

**P6.11 Over-Current Stall Prevention During Operation**

Range: 20 to 200%

Default Setting: 150

- During steady-state operation with motor load rapidly increasing, the AC drive output current may exceed the limit specified in P6.11. When this occurs, the output frequency will decrease to maintain a constant motor speed. The drive will accelerate to the steady-state output frequency only when the output current drops below the level specified by P6.11.

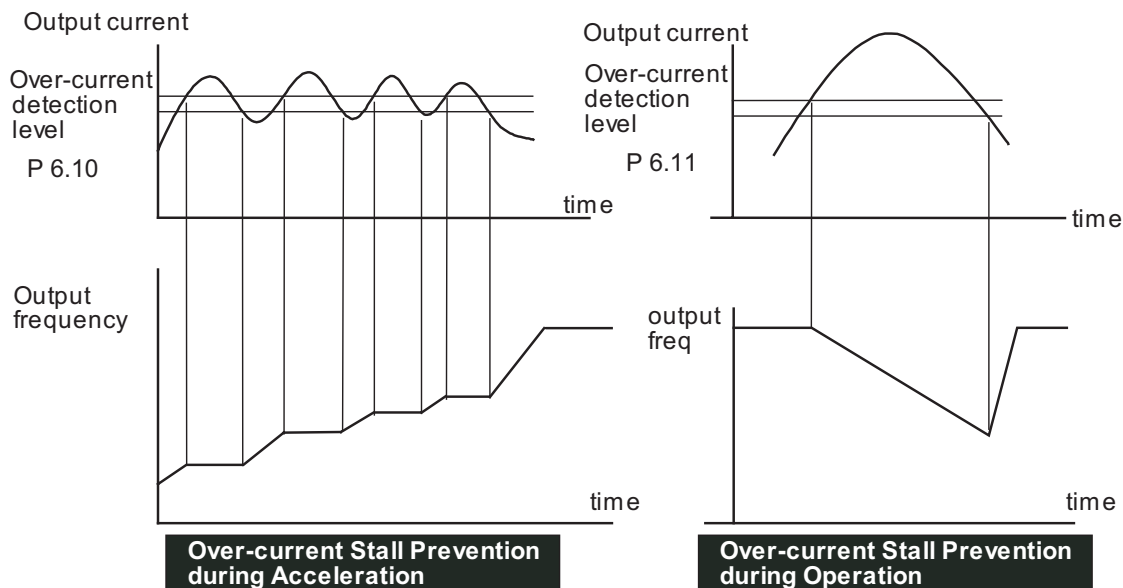

### P6.12 Maximum Allowable Power Loss Time

Range: 0.3 to 5.0 sec

Default Setting: 2.0

- During a power loss, if the power loss time is less than the time defined by this parameter, the AC drive will resume operation. If the Maximum Allowable Power Loss Time is exceeded, the AC drive output is turned off.

### P6.13 Base-Block Time for Speed Search

Range: 0.3 to 5.0 sec

Default Setting: 0.5

- When a momentary power loss is detected, the AC drive turns off for a specified time interval determined by P6.13 before resuming operation. This time interval is called Base-Block. This parameter should be set to a value where the residual output voltage due to regeneration is nearly zero, before the drive resumes operation.
- This parameter also determines the searching time when performing external Base-Block and Fault Reset (P6.01)

### P6.14 Maximum Speed Search Current Level

Range: 30 to 200%

Default Setting: 150

- Following a power failure, the AC drive will start its speed search operation only if the output current is greater than the value determined by P6.14. When the output current is less than that of P6.14, the AC drive output frequency is at a "speed synchronization point". The drive will start to accelerate or decelerate back to the operating frequency at which it was running prior to the power failure.

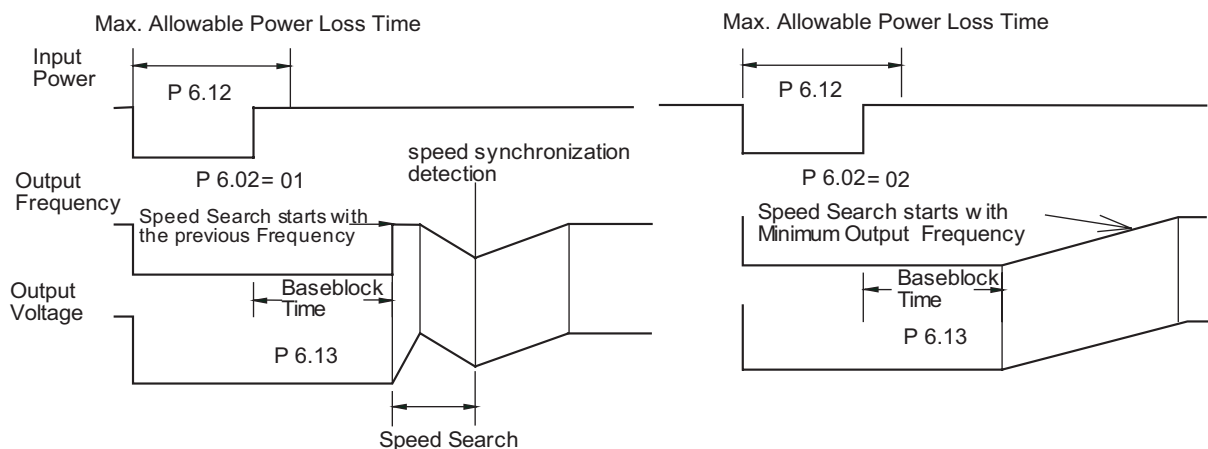

**P6.15 Upper Bound of Output Frequency**

Range: 0.1 to 400 Hz

Default Setting: 400

- The Upper/Lower Bound of Output Frequency is to prevent operation error and machine damage.
- This parameter must be equal to or greater than the Lower Bound of Output Frequency (P6.16).
- If the Upper Bound of Output Frequency is 50 Hz and the Maximum Output Frequency is 60 Hz, then any Command Frequency above 50 Hz will generate a 50 Hz output from the drive.
- The Output Frequency is also limited by the Motor Maximum RPM (P0.04).

**P6.16 Lower Bound of Output Frequency**

Range: 0.0 to 400 Hz

Default Setting: 0.0

- The Upper/Lower Bound of Output Frequency is to prevent operation error and machine damage.
- This parameter must be equal to or less than the Upper Bound of Output Frequency (P6.15).
- If the Lower Bound of Output Frequency is 10 Hz, and the Minimum Output Frequency (P2.06) is set at 1.0 Hz, then any Command Frequency between 1-10 Hz will generate a 10 Hz output from the drive.
- The Upper/Lower Bound of Output Frequency is to prevent operation error and machine damage.

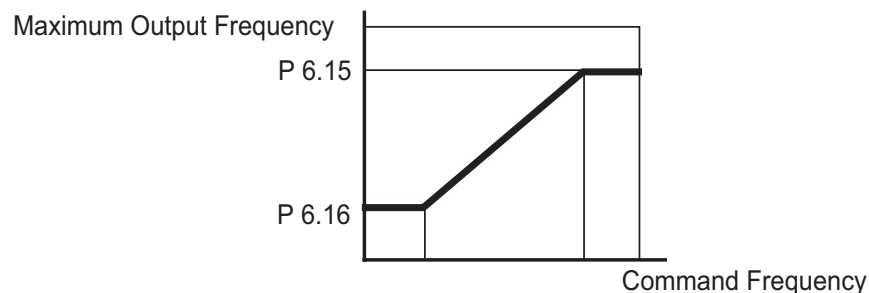
**P6.30 Line Start Lockout**

Default Setting: 00

|           |    |                            |
|-----------|----|----------------------------|
| Settings: | 00 | Enable Line Start Lockout  |
|           | 01 | Disable Line Start Lockout |

When this parameter is enabled, the AC Motor Drive will not start when powered up with a RUN command already applied. The drive must see the RUN command change from STOP to RUN before it will start.

When this parameter is disabled, the AC Motor Drive will start when powered up with a RUN command already applied.

|              |  |
|--------------|--|
| <b>P6.31</b> | <b>Present Fault Record</b>            |
| <b>P6.32</b> | <b>Second Most Recent Fault Record</b> |
| <b>P6.33</b> | <b>Third Most Recent Fault Record</b>  |
| <b>P6.34</b> | <b>Fourth Most Recent Fault Record</b> |
| <b>P6.35</b> | <b>Fifth Most Recent Fault Record</b>  |
| <b>P6.36</b> | <b>Sixth Most Recent Fault Record</b>  |

Default Setting: 00

Settings for P6.31 - P6.36:

|    |  |
|----|--|
| 00 | No Fault occurred                      |
| 01 | Over-current (oc)                      |
| 02 | Over-voltage (ov)                      |
| 03 | Overheat (oH)                          |
| 04 | Overload (oL)                          |
| 05 | Overload 1 (oL1)                       |
| 06 | Overload 2 (oL2)                       |
| 07 | External Fault (EF)                    |
| 08 | CPU failure 1 (CF1)                    |
| 09 | CPU failure 2 (CF2)                    |
| 10 | CPU failure 3 (CF3)                    |
| 11 | Hardware Protection Failure (HPF)      |
| 12 | Over-current during accel (OCA)        |
| 13 | Over-current during decel (OCd)        |
| 14 | Over-current during steady state (OCn) |
| 15 | Ground fault or fuse failure (GFF)     |
| 16 | Reserved                               |
| 17 | Input Power 3 phase loss               |
| 18 | External Base Block (bb)               |
| 19 | Auto Adjust Accel/decel failure (cFA)  |
| 20 | Software protection code (co)          |

# PID Parameters

## P7.00 Input Terminal for PID Feedback

Default Setting: 00

- Settings:
- 00 Inhibit PID operation.
  - 01 Forward-acting (heating loop) PID feedback, PV from AVI (0 to +10V)
  - 02 Forward-acting (heating loop) PID feedback, PV from ACI (4 to 20mA)
  - 03 Reverse-acting (cooling loop) PID feedback, PV from AVI (0 to +10V)
  - 04 Reverse-acting (cooling loop) PID feedback, PV from ACI (4 to 20mA)

### Forward-acting Loop

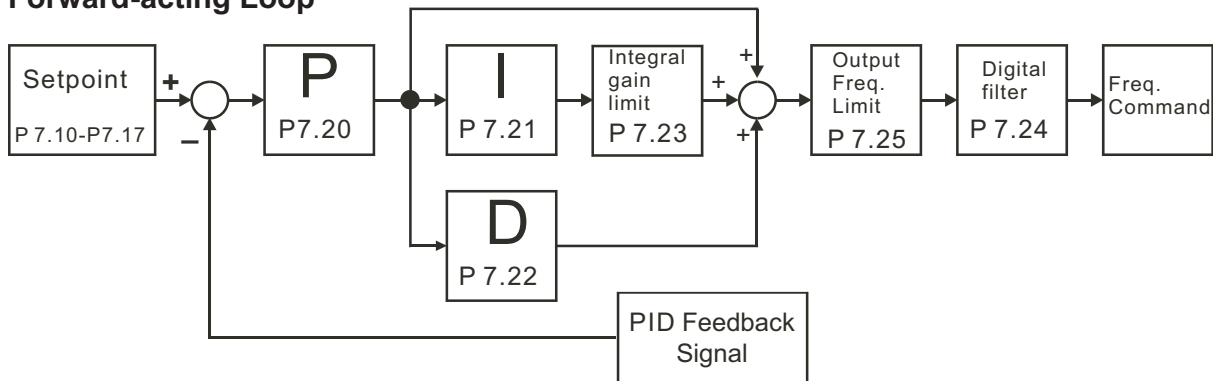

### Reverse-acting Loop

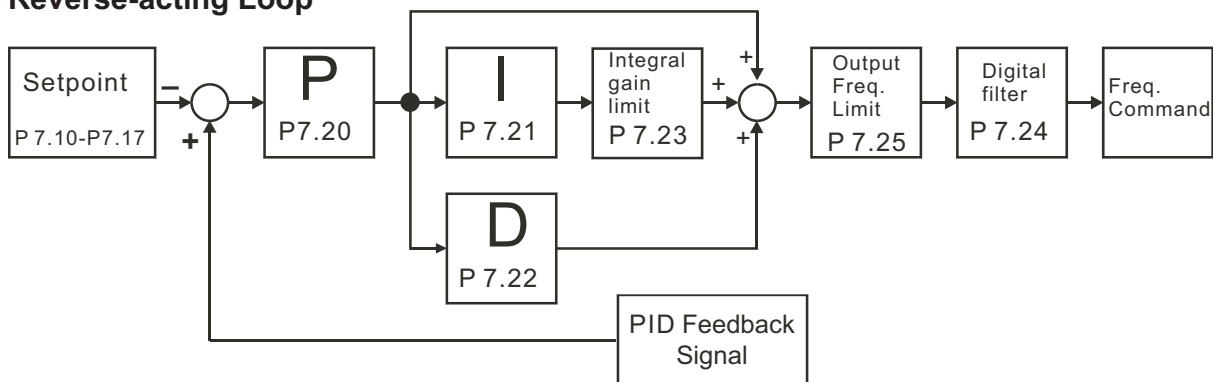

Note: Reverse-acting PID loops are available only for GS2 AC drives with firmware version 1.04 or higher.



Note: When using PID operation, the Source of Frequency parameter (P4.00) must be set to 00 or 01. If PID operation is disabled, the AC drive will operate using the Source of Frequency specified by P4.00.

### **P7.01** PV 100% Value

Range: 0.0 to 999

Default Setting: 100.0

This parameter should be set to the value corresponding to the 100% value of the process variable (PV). The setting for P7.01 cannot be less than any setting for P7.10 to P7.17.



*Note: The setting for PV 100% value (P7.01) cannot be set less than any value set for P7.10 to P7.17. If you are unable to reduce P7.01 to the desired value, check parameters P7.10 to P7.17 and reduce these values accordingly.*

### **P7.02** PID Setpoint Source

Settings: 00 - Keypad

01 - Serial Communications

Default Setting: 00

### **P7.10** ◆ Keypad PID Setpoint

Range: 0.0 to 999

Default Setting: 0.0



*Note: The settings for P7.10 to P7.17 cannot exceed the setting for P7.01.*

### **P7.11** ◆ PID Multi-setpoint 1

Range: 0.0 to 999

Default Setting: 0.0

- The Multi-Function Input Terminals DI3 to DI6 are used to select one of the PID Multi-Setpoints. (For further explanation, refer to settings 03, 04, and 05 for P3.02 to P3.05.) The setpoints are determined by P7.11 to P7.17.

### **P7.12** ◆ PID Multi-setpoint 2

Range: 0.0 to 999

Default Setting: 0.0

- Refer to P7.11 for explanation.

### **P7.13** ◆ PID Multi-setpoint 3

Range: 0.0 to 999

Default Setting: 0.0

- Refer to P7.11 for explanation.

### **P7.14** ◆ PID Multi-setpoint 4

Range: 0.0 to 999

Default Setting: 0.0

- Refer to P7.11 for explanation.

### **P7.15** ◆ PID Multi-setpoint 5

Range: 0.0 to 999

Default Setting: 0.0

- Refer to P7.11 for explanation.

**P7.16** ◆ PID Multi-setpoint 6

Range: 0.0 to 999

Default Setting: 0.0

•Refer to P7.11 for explanation.

**P7.17** ◆ PID Multi-setpoint 7

Range: 0.0 to 999

Default Setting: 0.0

•Refer to P7.11 for explanation.

**P7.20** ◆ Proportional Control (P)

Range: 0.0 to 10.0

Default Setting: 1.0

The first parameter of PID control is Proportional Control (P). For a given process, if the Proportional Value is set too low, the control action will be too sluggish. If the Proportional value is set too high, the control action will be unstable (erratic).

Set the Integral Control (I) and Derivative Control (D) to zero (0). Begin tuning the process with a low Proportional Value, and increase the Proportional value until the system goes unstable (erratic). When instability is reached, reduce the Proportional Value slightly until the system becomes stable (smaller values reduce system Gain). Stability can be tested by moving between two wide-spread setpoint values.

With 10% deviation and  $P=1$ , then  $P \times 10\% = \text{Control Output}$ . For example, if the speed of a motor is dragged down 10% due to a load increase, a corrective speed signal increase of 10% is generated. In a perfect world, this increase in speed command should bring the motor speed back to normal.

**P7.21** ◆ Integral Control (I)

Range: 0.00 to 100.0 sec (0.00 disable)

Default Setting: 1.00

Using only the Proportional Control, the corrective action may not increase fast enough or the setpoint may never be reached because of system losses. The Integral Control is used to generate additional corrective action.

When tuning, begin with a large Integral value and reduce the value until the system goes unstable (erratic). When instability is reached, increase the Integral value slightly until the system becomes stable and the desired setpoint value is reached.

**P7.22** ◆ Derivative Control (D)

Range: 0.00 to 1.00 sec

Default Setting: 0.00

If the control output is too sluggish after the Proportional Control (P) and Integral Control (I) values are set, Derivative Control (D) may be required. Begin with a high Derivative value and reduce the value to the point of system instability. Then increase the Derivative value until the control output regains stability. Stability can be tested by moving between two wide-spread setpoint values.

### P7.23 Upper Bound for Integral Control

Range: 00 to 100%

Default Setting: 100

- This parameter defines an upper boundary or limit for the integral gain (I) and therefore limits the Master Frequency. Use the formula below to calculate the Integral upper limit.

$$\text{Max. Output Frequency} = \left( \frac{\text{Motor Max. RPM (P0-04)}}{\text{Motor Base RPM (P0-03)}} \right) \times \text{Base Frequency (P0-02)}$$

- The formula is: Integral upper limit = (Maximum Output Frequency) X P7.23. This parameter can limit the Maximum Output Frequency

### P7.24 Derivative Filter Time Constant

Range: 0.0 to 2.5 sec

Default Setting: 0.0

- To avoid amplification of measured noise in the controller output, a derivative digital filter is inserted. This filter helps smooth oscillations. Larger values for P7.24 provide more smoothing.

### P7.25 PID Output Frequency Limit

Range: 00 to 110%

Default Setting: 100

- This parameter defines the percentage of output frequency limit during the PID control. The formula is Output Frequency Limit = (Maximum Output Frequency) X P7.25. This parameter will limit the Maximum Output Frequency.

$$\text{Max. Output Frequency} = \left( \frac{\text{Motor Max. RPM (P0-04)}}{\text{Motor Base RPM (P0-03)}} \right) \times \text{Base Frequency (P0-02)}$$

### P7.26 Feedback Signal Loss Detection Time

Range: 0.0 to 3600 sec

Default Setting: 60

- This parameter defines how long the PID Feedback signal is lost before an error is generated. Setting this parameter to 0.0 disables the PID Feedback loss timer. When the feedback signal is lost, PID Feedback loss timer starts timing. When the timer value is greater than the setting value of P. 7.26, the PID Feedback Loss parameter (P7.27) is activated. Furthermore, the Keypad will display "FbE" means the feedback abnormality detected. When the signal is corrected, the warning message "FbE" will automatically be cleared.

### P7.27 PID Feedback Loss Operation

Range: 00 - Warn and AC Drive Stop  
01 - Warn and Continue Operation

Default Setting: 00

- This parameter sets the operation of the drive when there is a loss of the PID feedback signal.
- This parameter only functions with 4-20ma for feedback loss operation.



## Display Parameters

### P8.00 ◆ User Defined Display Function

Default Setting: 00

|           |    |                          |
|-----------|----|--------------------------|
| Settings: | 00 | Output Frequency (Hz)    |
|           | 01 | Motor Speed (RPM)        |
|           | 02 | Output Frequency x P8.01 |
|           | 03 | Output Current (A)       |
|           | 04 | Motor Output Current (%) |
|           | 05 | Output Voltage(V)        |
|           | 06 | DC Bus Voltage (V)       |
|           | 07 | PID Setpoint             |
|           | 08 | PID Feedback (PV)        |
|           | 09 | Frequency Setpoint       |

### P8.01 ◆ Frequency Scale Factor

Range: 0.01 to 160.0

Default Setting: 1.0

This parameter can be used to multiply the display unit by a scaling factor so that the display will represent some other user desired unit. For example, the user may want to scale the drive display to represent ft/min for a motor that is driving a conveyor.

The coefficient K determines the multiplying factor for the user-defined unit.

- The display value is calculated as follows:

$$\text{Display value} = \text{output frequency} \times K$$

- The display window is only capable of showing four digits, but P8.01 can be used to create larger numbers. The display window uses decimal points to signify numbers up to five digits as explained below:

#### **DISPLAY      NUMBER REPRESENTED**

|       |   |
|-------|---|
| 9999  | The absence of a decimal point indicates a four digit integer.  |
| 999.9 | A single decimal point between the middle and the right-most numbers is a true decimal point; it separates ones and tenths as in "300.5 (three hundred and one-half).   |
| 9999. | A single decimal point after the right-most number is not a true decimal point; instead it indicates that a zero follows the right-most numbers. For example, the number 12340 would be displayed as "1234.". |

## Communication Parameters

### P9.00 Communication Address

Range: 01 to 254

Default Setting: 01

- If the AC drive is controlled by serial communication, the communication address must be set via this parameter.

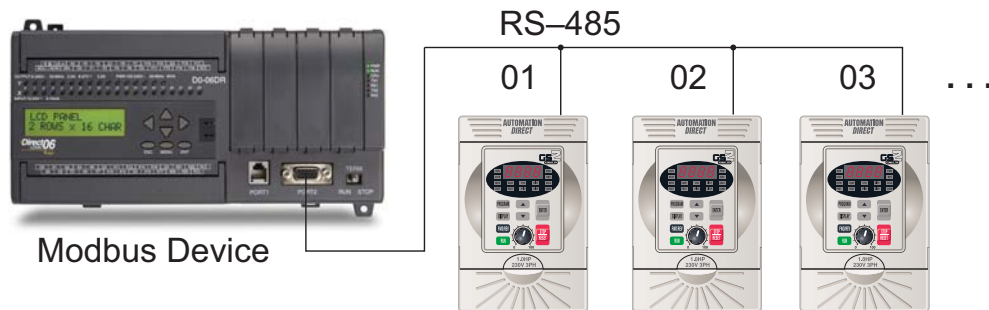

### P9.01 Transmission Speed

Range: 00 to 03

Default Setting: 01

|         |  |
|---------|--|
| Setting | 00: 4800 baud data transmission speed  |
|         | 01: 9600 baud data transmission speed  |
|         | 02: 19200 baud data transmission speed |
|         | 03: 38400 baud data transmission speed |

- Users can set parameters and control the operation of the AC drive via the RS-485 serial interface of a personal computer. This parameter is used to set the transmission speed between the computer and AC drive.

### P9.02 Communication Protocol

Default Setting: 00

|           |    |   |
|-----------|----|---|
| Settings: | 00 | MODBUS ASCII mode.<br><7 data bits, no parity, 2 stop bits> |
|           | 01 | MODBUS ASCII mode<br><7 data bits, even parity, 1 stop bit> |
|           | 02 | MODBUS ASCII mode<br><7 data bits, odd parity, 1 stop bit>  |
|           | 03 | MODBUS RTU mode<br><8 data bits, no parity, 2 stop bits>    |
|           | 04 | MODBUS RTU mode<br><8 data bits, even parity, 1 stop bit>   |
|           | 05 | MODBUS RTU mode<br><8 data bits, odd parity, 1 stop bit>    |

**P9.03** Transmission Fault Treatment

Default Setting: 00

- Settings:
- 00 - Display fault and continue operating
  - 01 - Display fault and RAMP to stop
  - 02 - Display fault and COAST to stop
  - 03 - No fault displayed and continue operating

**P9.04** Time Out Detection

Range: 00 - Disable  
01 - Enable

Default Setting: 00

- This parameter is used for ASCII mode. When this parameter is set to 01, it indicates that the over-time detection is enabled and the time slot between each character cannot exceed 500 ms.

**P9.05** Time Out Duration

Range: 0.1 to 60.0 seconds

Default Setting: 0.5

**P9.07** ◆ Parameter Lock

Default Setting: 00

- Settings:
- 00 All parameters can be set and read
  - 01 All parameters are read only

**P9.08** Restore to Default

Settings: 0 or 99

Default Setting: 00

- **Setting 99 restores all parameters to factory defaults.** ••

### **P9.11** ◆ Block Transfer Parameter 1

Range: P0.00 to P8.01, P9.99

Default Setting: P9.99

The sequential block transfer parameters (P9.11 through P9.25) allow you to "group" various miscellaneous non-sequential parameters, so that only one PLC programming write instruction is required to update those parameters, instead of three separate write instructions.

- Example:

Writing directly to three non-sequential parameters P1.00, P1.02, and P1.04 requires three separate write instructions from the PLC. However, those drive parameters can be updated with only one PLC write instruction to the sequential transfer blocks P9.11 through P9.13; if P9.11 is set to P1.00, P9.12 is set to P1.02, and P9.13 is set to P1.04.

### **P9.12** ◆ Block Transfer Parameter 2

Range: P0.00 to P8.01, P9.99

Default Setting: P9.99

### **P9.13** ◆ Block Transfer Parameter 3

Range: P0.00 to P8.01, P9.99

Default Setting: P9.99

### **P9.14** ◆ Block Transfer Parameter 4

Range: P0.00 to P8.01, P9.99

Default Setting: P9.99

### **P9.15** ◆ Block Transfer Parameter 5

Range: P0.00 to P8.01, P9.99

Default Setting: P9.99

### **P9.16** ◆ Block Transfer Parameter 6

Range: P0.00 to P8.01, P9.99

Default Setting: P9.99

### **P9.17** ◆ Block Transfer Parameter 7

Range: P0.00 to P8.01, P9.99

Default Setting: P9.99

### **P9.18** ◆ Block Transfer Parameter 8

Range: P0.00 to P8.01, P9.99

Default Setting: P9.99

### **P9.19** ◆ Block Transfer Parameter 9

Range: P0.00 to P8.01, P9.99

Default Setting: P9.99

**P9.20** ◆ Block Transfer Parameter 10Range: P0.00 to P8.01, P9.99 Default Setting: P9.99**P9.21** ◆ Block Transfer Parameter 11Range: P0.00 to P8.01, P9.99 Default Setting: P9.99**P9.22** ◆ Block Transfer Parameter 12Range: P0.00 to P8.01, P9.99 Default Setting: P9.99**P9.23** ◆ Block Transfer Parameter 13Range: P0.00 to P8.01, P9.99 Default Setting: P9.99**P9.24** ◆ Block Transfer Parameter 14Range: P0.00 to P8.01, P9.99 Default Setting: P9.99**P9.25** ◆ Block Transfer Parameter 15Range: P0.00 to P8.01, P9.99 Default Setting: P9.99**P9.26** ◆ Serial Comm Speed ReferenceRange: 0.0 to 400.0 Hz Default Setting: 60.0

- This parameter is used to set the Frequency Command when the AC drive is controlled by communication interface.



---

*Note: In order for this parameter to function, the Source of Frequency Command (P4.00) must be set to 05.*

---

**P9.27** ◆ Serial Comm RUN CommandRange: 00 - Stop Default Setting: 00  
01 - Run**P9.28** ◆ Serial Comm Direction CommandRange: 00 - Forward Default Setting: 00  
01 - Reverse

### **P9.29** ◆ Serial Comm External Fault

Range: 00 - No action  
01 - External fault

Default Setting: 00

### **P9.30** ◆ Serial Comm Fault Reset

Range: 00 - No action  
01 - Fault Reset

Default Setting: 00

### **P9.31** ◆ Serial Comm JOG Command

Range: 00 - Stop  
01 - Jog

Default Setting: 00

### **P9.39** Firmware Version

Range: #.##

Default Setting: #.##

### **P9.41** GS Series Number

Default Setting: ##

|           |    |     |
|-----------|----|-----|
| Settings: | 01 | GS1 |
|           | 02 | GS2 |
|           | 03 | GS3 |
|           | 04 | GS4 |

**P9.42****Manufacturer Model Information**

Default Setting: ##

|           |    |                                |
|-----------|----|--------------------------------|
| Settings: | 00 | GS2-20P5 (230V 1 ph/3ph 0.5hp) |
|           | 01 | GS2-21P0 (230V 1 ph/3ph 1hp)   |
|           | 02 | GS2-22P0 (230V 1ph/3ph 2hp)    |
|           | 03 | GS2-23P0 (230V 1ph/3ph 3hp)    |
|           | 04 | GS2-25P0 (230V 3ph 5hp)        |
|           | 05 | GS2-27P5 (230V 3ph 7.5hp)      |
|           | 06 | Reserved                       |
|           | 07 | GS2-41P0 (460V 3ph 1hp)        |
|           | 08 | GS2-42P0 (460V 3ph 2hp)        |
|           | 09 | GS2-43P0 (460V 3ph 3hp)        |
|           | 10 | GS2-45P0 (460V 3ph 5hp)        |
|           | 11 | GS2-47P0 (460V 3ph 7.5 hp)     |
|           | 12 | GS2-4010 (460V 3ph 10hp)       |
|           | 13 | GS2-10P2 (115V 1ph 0.25hp)     |
|           | 14 | GS2-10P5 (115V 1ph 0.5hp)      |
|           | 15 | GS2-11P0 (115V 1ph 1hp)        |
|           | 16 | Reserved                       |
|           | 17 | Reserved                       |
|           | 18 | Reserved                       |
|           | 19 | Reserved                       |
|           | 20 | Reserved                       |
|           | 21 | GS2-51P0 (575V 3ph 1hp)        |
|           | 22 | GS2-52P0 (575V 3ph 2hp)        |
|           | 23 | GS2-53P0 (575V 3ph 3hp)        |
|           | 24 | GS2-55P0 (575V 3ph 5hp)        |
|           | 25 | GS2-57P5 (575V 3ph 7.5hp)      |
|           | 26 | GS2-5010 (575V 3ph 10hp)       |





# GS2 MODBUS COMMUNICATIONS

---



# CHAPTER 5

## In This Chapter...

|   |       |
|---|-------|
| Communication Parameters Summary . . . . .              | .5-2  |
| GS2 Parameter Memory Addresses . . . . .                | .5-4  |
| GS2 Status Addresses . . . . .                          | .5-9  |
| Communicating with <i>DirectLogic</i> PLCs . . . . .    | .5-12 |
| Step 1: Choose the Appropriate CPU. . . . .             | .5-12 |
| Step 2: Make the Connections . . . . .                  | .5-12 |
| Step 3: Set AC Drive Parameters . . . . .               | .5-14 |
| Step 4: Configure the <i>DirectLOGIC</i> CPUs . . . . . | .5-14 |
| <i>DirectLOGIC</i> Modbus Port Configuration . . . . .  | .5-15 |
| <i>DirectLOGIC</i> Modbus Ladder Programming . . . . .  | .5-16 |
| Communicating with Third-party Devices . . . . .        | .5-30 |
| Data Format . . . . .                                   | .5-31 |
| Communication Protocol . . . . .                        | .5-32 |

## Communication Parameters Summary

A summary of the GS2 Communications Parameters is listed below. For a complete listing of the GS2 Parameter, refer to CHAPTER 4.

| Communications Parameters                      |                              |  |         |
|--|------------------------------|--|---------|
| GS2 Parameter                                  | Description                  | Range  | Default |
| <b>P 9.00</b>                                  | Communication Address        | 01 to 254  | 01      |
| <b>P 9.01</b>                                  | Transmission Speed           | 00: 4800 baud<br>01: 9600 baud<br>02: 19200 baud<br>03: 38400 baud   | 01      |
| <b>P 9.02</b>                                  | Communication Protocol       | 00: Modbus ASCII mode<br>7 data bits,no parity,2 stop bits<br>01: Modbus ASCII mode<br>7 data bits,even parity,1 stop bit<br>02: Modbus ASCII mode<br>7 data bits,odd parity,1 stop bit<br>03: Modbus RTU mode<br>8 data bits,no parity,2 stop bits<br>04: Modbus RTU mode<br>8 data bits,even parity,1 stop bit<br>05: Modbus RTU mode<br>8 data bits,odd parity,1 stop bit | 00      |
| <b>P 9.03</b>                                  | Transmission Fault Treatment | 00: Display fault and continue operating<br>01: Display fault and RAMP to stop<br>02: Display fault and COAST to stop<br>03: No fault displayed and continue operating   | 00      |
| <b>P 9.04</b>                                  | Time Out Detection           | 00: Disable<br>01: Enable  | 00      |
| <b>P 9.05</b>                                  | Time Out Duration            | 0.1 to 60.0 seconds  | 0.5     |
| <b>◆ P 9.07</b>                                | Parameter Lock               | 00: All parameters can be set and read<br>01: All parameters are read-only   | 00      |
| <b>P 9.08</b>                                  | Restore to Default           | 99: Restores all parameters to factory defaults  | 00      |
| <b>◆ P 9.11</b>                                | Block Transfer Parameter 1   | P0.00 to P8.01, P9.99  | P 9.99  |
| <b>◆ P 9.12</b>                                | Block Transfer Parameter 2   | P0.00 to P8.01, P9.99  | P 9.99  |
| <b>◆ P 9.13</b>                                | Block Transfer Parameter 3   | P0.00 to P8.01, P9.99  | P 9.99  |
| <b>◆ P 9.14</b>                                | Block Transfer Parameter 4   | P0.00 to P8.01, P9.99  | P 9.99  |
| <b>◆ P 9.15</b>                                | Block Transfer Parameter 5   | P0.00 to P8.01, P9.99  | P 9.99  |
| <b>◆ P 9.16</b>                                | Block Transfer Parameter 6   | P0.00 to P8.01, P9.99  | P 9.99  |
| <b>◆ P 9.17</b>                                | Block Transfer Parameter 7   | P0.00 to P8.01, P9.99  | P 9.99  |
| <b>◆ Parameter can be set during RUN Mode.</b> |                              |  |         |

| Communications Parameters (continued)   |                                |   |         |
|---|--------------------------------|---|---------|
| GS2 Parameter                           | Description                    | Range   | Default |
| ◆ P 9.18                                | Block Transfer Parameter 8     | P0.00 to P8.01, P9.99   | P 9.99  |
| ◆ P 9.19                                | Block Transfer Parameter 9     | P0.00 to P8.01, P9.99   | P 9.99  |
| ◆ P 9.20                                | Block Transfer Parameter 10    | P0.00 to P8.01, P9.99   | P 9.99  |
| ◆ P 9.21                                | Block Transfer Parameter 11    | P0.00 to P8.01, P9.99   | P 9.99  |
| ◆ P 9.22                                | Block Transfer Parameter 12    | P0.00 to P8.01, P9.99   | P 9.99  |
| ◆ P 9.23                                | Block Transfer Parameter 13    | P0.00 to P8.01, P9.99   | P 9.99  |
| ◆ P 9.24                                | Block Transfer Parameter 14    | P0.00 to P8.01, P9.99   | P 9.99  |
| ◆ P 9.25                                | Block Transfer Parameter 15    | P0.00 to P8.01, P9.99   | P 9.99  |
| ◆ P 9.26                                | Serial Comm Speed Reference    | 0.0 to 400.0 Hz   | 60.0    |
| ◆ P 9.27                                | Serial Comm RUN Command        | 00: Stop<br>01: Run   | 00      |
| ◆ P 9.28                                | Serial Comm Direction Command  | 00: Forward<br>01: Reverse  | 00      |
| ◆ P 9.29                                | Serial Comm External Fault     | 00: No fault<br>01: External fault  | 00      |
| ◆ P 9.30                                | Serial Comm Fault Reset        | 00: No action<br>01: Fault Reset  | 00      |
| ◆ P 9.31                                | Serial Comm JOG Command        | 00: Stop<br>01: Jog   | 00      |
| P 9.39                                  | Firmware Version               | ###   | ###     |
| P 9.41                                  | GS Series Number               | 01: GS1<br>02: GS2<br>03: GS3   | ##      |
| P 9.42                                  | Manufacturer Model Information | 00: GS2-20P5 (230V 1ph/3ph 0.5hp)<br>01: GS2-21P0 (230V 1ph/3ph 1hp)<br>02: GS2-22P0 (230V 1ph/3ph 2hp)<br>03: GS2-23P0 (230V 1ph/3ph 3hp)<br>04: GS2-25P0 (230V 3ph 5hp)<br>05: GS2-27P5 (230V 3ph 7.5hp)<br>06: Reserved<br>07: GS2-41P0 (460V 3ph 1hp)<br>08: GS2-42P0 (460V 3ph 2hp)<br>09: GS2-43P0 (460V 3ph 3hp)<br>10: GS2-45P0 (460V 3ph 5hp)<br>11: GS2-47P5 (460V 3ph 7.5hp)<br>12: GS2-4010 (460V 3ph 10hp)<br>13: GS2-10P2 (115V 1ph 0.25hp)<br>14: GS2-10P5 (115V 1ph 0.5hp)<br>15: GS2-11P0 (115V 1ph 1hp)<br>16~20: Reserved<br>21: GS2-51P0 (575V 3ph 1hp)<br>22: GS2-52P0 (575V 3ph 2hp)<br>23: GS2-53P0 (575V 3ph 3hp)<br>24: GS2-55P0 (575V 3ph 5hp)<br>25: GS2-57P5 (575V 3ph 7.5hp)<br>26: GS2-5010 (575V 3ph 10hp) | ##      |
| ◆ Parameter can be set during RUN Mode. |                                |   |         |

## GS2 Parameter Memory Addresses

| Parameter Memory Addresses              |   |             |                |       |
|---|---|-------------|----------------|-------|
| GS2 Parameter                           | Description                             | Hexadecimal | Modbus Decimal | Octal |
| <b>Motor Parameter Addresses</b>        |   |             |                |       |
| P 0.00                                  | Motor Nameplate Voltage                 | 0000        | 40001          | 0     |
| P 0.01                                  | Motor Nameplate Amps                    | 0001        | 40002          | 1     |
| P 0.02                                  | Motor Base Frequency                    | 0002        | 40003          | 2     |
| P 0.03                                  | Motor Base RPM                          | 0003        | 40004          | 3     |
| P 0.04                                  | Motor Maximum RPM                       | 0004        | 40005          | 4     |
| <b>Ramp Parameter Addresses</b>         |   |             |                |       |
| P 1.00                                  | Stop Methods                            | 0100        | 40257          | 400   |
| ◆ P 1.01                                | Acceleration Time 1                     | 0101        | 40258          | 401   |
| ◆ P 1.02                                | Deceleration Time 1                     | 0102        | 40259          | 402   |
| P 1.03                                  | Accel S-curve                           | 0103        | 40260          | 403   |
| P 1.04                                  | Decel S-curve                           | 0104        | 40261          | 404   |
| ◆ P 1.05                                | Acceleration Time 2                     | 0105        | 40262          | 405   |
| ◆ P 1.06                                | Deceleration Time 2                     | 0106        | 40263          | 406   |
| P 1.07                                  | Select method to use 2nd Accel/Decel    | 0107        | 40264          | 407   |
| P 1.08                                  | Accel 1 to Accel 2 frequency transition | 0108        | 40265          | 410   |
| P 1.09                                  | Decel 2 to Decel 1 frequency transition | 0109        | 40266          | 411   |
| P 1.10                                  | Skip Frequency 1                        | 010A        | 40267          | 412   |
| P 1.11                                  | Skip Frequency 2                        | 010B        | 40268          | 413   |
| P 1.12                                  | Skip Frequency 3                        | 010C        | 40269          | 414   |
| P 1.17                                  | Skip Frequency Band                     | 0111        | 40274          | 421   |
| P 1.18                                  | DC Injection Current Level              | 0112        | 40275          | 422   |
| P 1.20                                  | DC Injection during Start-up            | 0114        | 40277          | 424   |
| P 1.21                                  | DC Injection during Stopping            | 0115        | 40278          | 425   |
| P 1.22                                  | Start-point for DC Injection            | 0116        | 40279          | 426   |
| <b>Volts/Hertz Parameter Addresses</b>  |   |             |                |       |
| P 2.00                                  | Volts/Hertz Settings                    | 0200        | 40513          | 1000  |
| ◆ P 2.01                                | Slip Compensation                       | 0201        | 40514          | 1001  |
| ◆ P 2.02                                | Auto-torque Boost                       | 0202        | 40515          | 1002  |
| P 2.04                                  | Mid-point Frequency                     | 0204        | 40517          | 1004  |
| P 2.05                                  | Mid-point Voltage                       | 0205        | 40518          | 1005  |
| P 2.06                                  | Min. Output Frequency                   | 0206        | 40519          | 1006  |
| P 2.07                                  | Min. Output Voltage                     | 0207        | 40520          | 1007  |
| P 2.08                                  | PWM Carrier Frequency                   | 0208        | 40521          | 1010  |
| ◆ Parameter can be set during RUN Mode. |   |             |                |       |

| Parameter Memory Addresses (continued)         |  |             |                |       |
|--|--|-------------|----------------|-------|
| GS2 Parameter                                  | Description                                | Hexadecimal | Modbus Decimal | Octal |
| <b>Digital Parameter Addresses</b>             |  |             |                |       |
| <b>P 3.00</b>                                  | Source of Operation Command                | 0300        | 40769          | 1400  |
| <b>P 3.01</b>                                  | Multi-function Input Terminals (DI1 - DI2) | 0301        | 40770          | 1401  |
| <b>P 3.02</b>                                  | Multi-function Input (DI3)                 | 0302        | 40771          | 1402  |
| <b>P 3.03</b>                                  | Multi-function Input (DI4)                 | 0303        | 40772          | 1403  |
| <b>P 3.04</b>                                  | Multi-function Input (DI5)                 | 0304        | 40773          | 1404  |
| <b>P 3.05</b>                                  | Multi-function Input (DI6)                 | 0305        | 40774          | 1405  |
| <b>P 3.11</b>                                  | Multi-Function Output Terminal 1           | 030B        | 40780          | 1413  |
| <b>P 3.12</b>                                  | Multi-Function Output Terminal 2           | 030C        | 40781          | 1414  |
| ◆ <b>P 3.16</b>                                | Desired Frequency                          | 0310        | 40785          | 1420  |
| ◆ <b>P 3.17</b>                                | Desired Current                            | 0311        | 40786          | 1421  |
| ◆ <b>P 3.18</b>                                | PID Deviation Level                        | 0312        | 40787          | 1422  |
| ◆ <b>P 3.19</b>                                | PID Deviation Time                         | 0313        | 40788          | 1423  |
| <b>Analog Parameter Addresses</b>              |  |             |                |       |
| <b>P 4.00</b>                                  | Source of Frequency Command                | 0400        | 41025          | 2000  |
| <b>P 4.01</b>                                  | Analog Input Offset Polarity               | 0401        | 41026          | 2001  |
| ◆ <b>P 4.02</b>                                | Analog Input Offset                        | 0402        | 41027          | 2002  |
| ◆ <b>P 4.03</b>                                | Analog Input Gain                          | 0403        | 41028          | 2003  |
| <b>P 4.04</b>                                  | Analog Input Reverse Motion Enable         | 0404        | 41029          | 2004  |
| <b>P 4.05</b>                                  | Loss of ACI Signal (4-20mA)                | 0405        | 41030          | 2005  |
| ◆ <b>P 4.11</b>                                | Analog Output Signal                       | 040B        | 41036          | 2013  |
| ◆ <b>P 4.12</b>                                | Analog Output Gain                         | 040C        | 41037          | 2014  |
| <b>Presets Parameter Addresses</b>             |  |             |                |       |
| ◆ <b>P 5.00</b>                                | Jog  | 0500        | 41281          | 2400  |
| ◆ <b>P 5.01</b>                                | Multi-Speed 1                              | 0501        | 41282          | 2401  |
| ◆ <b>P 5.02</b>                                | Multi-Speed 2                              | 0502        | 41283          | 2402  |
| ◆ <b>P 5.03</b>                                | Multi-Speed 3                              | 0503        | 41284          | 2403  |
| ◆ <b>P 5.04</b>                                | Multi-Speed 4                              | 0504        | 41285          | 2404  |
| ◆ <b>P 5.05</b>                                | Multi-Speed 5                              | 0505        | 41286          | 2405  |
| ◆ <b>P 5.06</b>                                | Multi-Speed 6                              | 0506        | 41287          | 2406  |
| ◆ <b>P 5.07</b>                                | Multi-Speed 7                              | 0507        | 41288          | 2407  |
| ◆ <b>Parameter can be set during RUN Mode.</b> |  |             |                |       |

| Parameter Memory Addresses (continued)         |   |             |                |       |
|--|---|-------------|----------------|-------|
| GS2 Parameter                                  | Description                                       | Hexadecimal | Modbus Decimal | Octal |
| <b>Protection Parameter Addresses</b>          |   |             |                |       |
| <b>P 6.00</b>                                  | Electronic Thermal Overload Relay                 | 0600        | 41537          | 3000  |
| <b>P 6.01</b>                                  | Auto Restart after Fault                          | 0601        | 41538          | 3001  |
| <b>P 6.02</b>                                  | Momentary Power Loss                              | 0602        | 41539          | 3002  |
| <b>P 6.03</b>                                  | Reverse Operation Inhibit                         | 0603        | 41540          | 3003  |
| <b>P 6.04</b>                                  | Auto Voltage Regulation                           | 0604        | 41541          | 3004  |
| <b>P 6.05</b>                                  | Over-Voltage Trip Protection                      | 0605        | 41542          | 3005  |
| <b>P 6.06</b>                                  | Auto Adjustable Accel/Decel                       | 0606        | 41543          | 3006  |
| <b>P 6.07</b>                                  | Over-Torque Detection Mode                        | 0607        | 41544          | 3007  |
| <b>P 6.08</b>                                  | Over-Torque Detection Level                       | 0608        | 41545          | 3010  |
| <b>P 6.09</b>                                  | Over-Torque Detection Time                        | 0609        | 41546          | 3011  |
| <b>P 6.10</b>                                  | Over-Current Stall Prevention during Acceleration | 060A        | 41547          | 3012  |
| <b>P 6.11</b>                                  | Over-Current Stall Prevention during Operation    | 060B        | 41548          | 3013  |
| <b>P 6.12</b>                                  | Maximum Allowable Power Loss Time                 | 060C        | 41549          | 3014  |
| <b>P 6.13</b>                                  | Base-Block Time for Speed Search                  | 060D        | 41550          | 3015  |
| <b>P 6.14</b>                                  | Maximum Speed Search Current Level                | 060E        | 41551          | 3016  |
| <b>P 6.15</b>                                  | Upper Bound of Output Frequency                   | 060F        | 41552          | 3017  |
| <b>P 6.16</b>                                  | Lower Bound of Output Frequency                   | 0610        | 41553          | 3020  |
| <b>P 6.31</b>                                  | Present Fault Record                              | 061F        | 41568          | 3037  |
| <b>P 6.32</b>                                  | Second Most Recent Fault Record                   | 0620        | 41569          | 3040  |
| <b>P 6.33</b>                                  | Third Most Recent Fault Record                    | 0621        | 41570          | 3041  |
| <b>P 6.34</b>                                  | Fourth Most Recent Fault Record                   | 0622        | 41571          | 3042  |
| <b>P 6.35</b>                                  | Fifth Most Recent Fault Record                    | 0623        | 41572          | 3043  |
| <b>P 6.36</b>                                  | Sixth Most Recent Fault Record                    | 0624        | 41573          | 3044  |
| <b>◆ Parameter can be set during RUN Mode.</b> |   |             |                |       |

| Parameter Memory Addresses (continued)         |                                  |             |                |       |
|--|----------------------------------|-------------|----------------|-------|
| GS2 Parameter                                  | Description                      | Hexadecimal | Modbus Decimal | Octal |
| <b>PID Parameter Addresses</b>                 |                                  |             |                |       |
| <b>P 7.00</b>                                  | Input Terminal for PID Feedback  | 0700        | 41793          | 3400  |
| <b>P 7.01</b>                                  | PV 100% Value                    | 0701        | 41794          | 3401  |
| <b>P 7.02</b>                                  | PID Setpoint Source              | 0702        | 41795          | 3402  |
| ◆ <b>P 7.10</b>                                | Keypad PID Setpoint              | 070A        | 41803          | 3412  |
| ◆ <b>P 7.11</b>                                | PID Multi-setpoint 1             | 070B        | 41804          | 3413  |
| ◆ <b>P 7.12</b>                                | PID Multi-setpoint 2             | 070C        | 41805          | 3414  |
| ◆ <b>P 7.13</b>                                | PID Multi-setpoint 3             | 070D        | 41806          | 3415  |
| ◆ <b>P 7.14</b>                                | PID Multi-setpoint 4             | 070E        | 41807          | 3416  |
| ◆ <b>P 7.15</b>                                | PID Multi-setpoint 5             | 070F        | 41808          | 3417  |
| ◆ <b>P 7.16</b>                                | PID Multi-setpoint 6             | 0710        | 41809          | 3420  |
| ◆ <b>P 7.17</b>                                | PID Multi-setpoint 7             | 0711        | 41810          | 3421  |
| ◆ <b>P 7.20</b>                                | Proportional Control             | 0714        | 41813          | 3424  |
| ◆ <b>P 7.21</b>                                | Integral Control                 | 0715        | 41814          | 3425  |
| ◆ <b>P 7.22</b>                                | Derivative Control               | 0716        | 41815          | 3426  |
| <b>P 7.23</b>                                  | Upper Bound for Integral Control | 0717        | 41816          | 3427  |
| <b>P 7.24</b>                                  | Derivative Filter Time Constant  | 0718        | 41817          | 3430  |
| <b>P 7.25</b>                                  | PID Output Frequency Limit       | 0719        | 41818          | 3431  |
| <b>P 7.26</b>                                  | Feedback Signal Detection Time   | 071A        | 41819          | 3432  |
| <b>P 7.27</b>                                  | PID Feedback Loss                | 071B        | 41820          | 3433  |
| <b>Display Parameter Addresses</b>             |                                  |             |                |       |
| ◆ <b>P 8.00</b>                                | User Defined Display Function    | 0800        | 42049          | 4000  |
| ◆ <b>P 8.01</b>                                | Frequency Scale Factor           | 0801        | 42050          | 4001  |
| ◆ <b>Parameter can be set during RUN Mode.</b> |                                  |             |                |       |

| Parameter Memory Addresses (continued)    |                                |             |                |       |
|---|--------------------------------|-------------|----------------|-------|
| GS2 Parameter                             | Description                    | Hexadecimal | Modbus Decimal | Octal |
| <b>Communications Parameter Addresses</b> |                                |             |                |       |
| P 9.00                                    | Communication Address          | 0900        | 42305          | 4400  |
| P 9.01                                    | Transmission Speed             | 0901        | 42306          | 4401  |
| P 9.02                                    | Communication Protocol         | 0902        | 42307          | 4402  |
| P 9.03                                    | Transmission Fault Treatment   | 0903        | 42308          | 4403  |
| P 9.04                                    | Time Out Detection             | 0904        | 42309          | 4404  |
| P 9.05                                    | Time Out Duration              | 0905        | 42310          | 4405  |
| ◆ P 9.07                                  | Parameter Lock                 | 0907        | 42312          | 4407  |
| P 9.08                                    | Restore to Default             | 0908        | 42313          | 4410  |
| ◆ P 9.11                                  | Block Transfer Parameter 1     | 090B        | 42316          | 4413  |
| ◆ P 9.12                                  | Block Transfer Parameter 2     | 090C        | 42317          | 4414  |
| ◆ P 9.13                                  | Block Transfer Parameter 3     | 090D        | 42318          | 4415  |
| ◆ P 9.14                                  | Block Transfer Parameter 4     | 090E        | 42319          | 4416  |
| ◆ P 9.15                                  | Block Transfer Parameter 5     | 090F        | 42320          | 4417  |
| ◆ P 9.16                                  | Block Transfer Parameter 6     | 0910        | 42321          | 4420  |
| ◆ P 9.17                                  | Block Transfer Parameter 7     | 0911        | 42322          | 4421  |
| ◆ P 9.18                                  | Block Transfer Parameter 8     | 0912        | 42323          | 4422  |
| ◆ P 9.19                                  | Block Transfer Parameter 9     | 0913        | 42324          | 4423  |
| ◆ P 9.20                                  | Block Transfer Parameter 10    | 0914        | 42325          | 4424  |
| ◆ P 9.21                                  | Block Transfer Parameter 11    | 0915        | 42326          | 4425  |
| ◆ P 9.22                                  | Block Transfer Parameter 12    | 0916        | 42327          | 4426  |
| ◆ P 9.23                                  | Block Transfer Parameter 13    | 0917        | 42328          | 4427  |
| ◆ P 9.24                                  | Block Transfer Parameter 14    | 0918        | 42329          | 4430  |
| ◆ P 9.25                                  | Block Transfer Parameter 15    | 0919        | 42330          | 4431  |
| ◆ P 9.26                                  | Serial Comm Speed Reference    | 091A        | 42331          | 4432  |
| ◆ P 9.27                                  | Serial Comm RUN Command        | 091B        | 42332          | 4433  |
| ◆ P 9.28                                  | Serial Comm Direction Command  | 091C        | 42333          | 4434  |
| ◆ P 9.29                                  | Serial Comm External Fault     | 091D        | 42334          | 4435  |
| ◆ P 9.30                                  | Serial Comm Fault Reset        | 091E        | 42335          | 4436  |
| ◆ P 9.31                                  | Serial Comm JOG Command        | 091F        | 42336          | 4437  |
| P 9.41                                    | GS Series Number               | 0929        | 42346          | 4451  |
| P 9.42                                    | Manufacturer Model Information | 092A        | 42347          | 4452  |
| ◆ Parameter can be set during RUN Mode.   |                                |             |                |       |



## GS2 Status Addresses

The GS2 Series AC drive has status memory addresses that are used to monitor the AC drive. The status addresses and value definitions are listed below.

### Status Addresses (Read Only)

| GS2 Status Addresses        |             |                |       |
|-----------------------------|-------------|----------------|-------|
| Description                 | Hexadecimal | Modbus Decimal | Octal |
| Status Monitor 1            | 2100        | 48449          | 20400 |
| Status Monitor 2            | 2101        | 48450          | 20401 |
| Frequency Command F         | 2102        | 48451          | 20402 |
| Output Frequency H          | 2103        | 48452          | 20403 |
| Output Current A            | 2104        | 48453          | 20404 |
| DC Bus Voltage d            | 2105        | 48454          | 20405 |
| Output Voltage U            | 2106        | 48455          | 20406 |
| Motor RPM                   | 2107        | 48456          | 20407 |
| Scale Frequency (Low Word)  | 2108        | 48457          | 20410 |
| Scale Frequency (High Word) | 2109        | 48458          | 20411 |
| Power Factor Angle          | 210A        | 48459          | 20412 |
| % Load                      | 210B        | 48460          | 20413 |
| Firmware Version            | 2110        | 48465          | 20420 |

### Status Monitor 1

**h2100**

#### Error Codes:

|                         |  |
|-------------------------|--|
| 00: No fault occurred   | 11: Hardware Protection Failure (HPF)      |
| 01: Over-current(oc)    | 12: Over-current during accel (ocA)        |
| 02: Over-voltage(ov)    | 13: Over-current during decel (ocd)        |
| 03: Overheat (oH)       | 14: Over-current during steady state (ocn) |
| 04: Overload (oL)       | 15: Ground fault or fuse failure (GFF)     |
| 05: Overload 1 (oL1)    | 16: Low voltage (Lv)                       |
| 06: Overload 2 (oL2)    | 17: Input power 3-phase loss (PHL)         |
| 07: External Fault (EF) | 18: External Base-Block (bb)               |
| 08: CPU failure 1 (cF1) | 19: Auto adjust accel/decel failure (cFA)  |
| 09: CPU failure 2 (cF2) | 20: Software protection code (code)        |
| 10: CPU failure 3 (cF3) |  |

**Status Monitor 2**

**h2101**

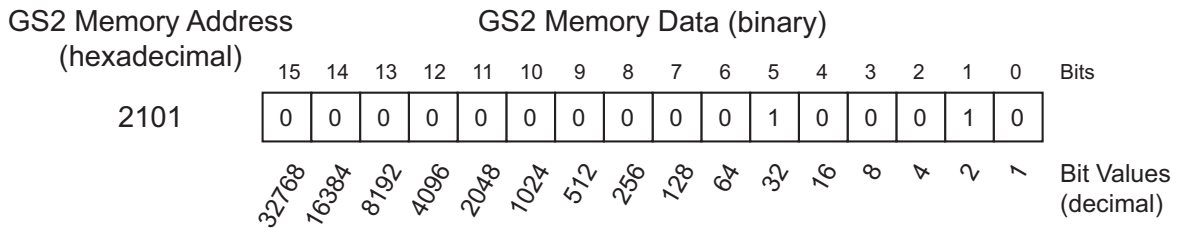

| Status Monitor 2 - Memory Address h2101 |                               |  |
|---|-------------------------------|--|
| Address Bit(s)                          | Bit(s) Value Binary (Decimal) | AC Drive Status  |
| 0 and 1                                 | 00 (0)                        | Drive operation stopped (STOP)   |
|   | 01 (1)                        | Run to Stop transition   |
|   | 10 (2)                        | Standby  |
|   | 11 (3)                        | Drive operation running (RUN)  |
| 2                                       | 1 (4)                         | JOG active   |
| 3 and 4                                 | 00 (0)                        | Rotational direction forward (FWD)                                       |
|   | 01 (8)                        | REV to FWD transition  |
|   | 10 (16)                       | FWD to REV transition  |
|   | 11 (24)                       | Rotational direction reverse (REV)                                       |
| 5                                       | 1 (32)                        | Source of frequency determined by serial comm interface (P4.00 = 5)      |
| 6                                       | 1 (64)                        | Source of frequency determined by AI terminal (P4.00 = 2, 3, or 4)       |
| 7                                       | 1 (128)                       | Source of operation determined by serial comm interface (P3.00 = 3 or 4) |
| 8                                       | 1 (256)                       | Parameters have been locked (9-07 = 1)                                   |
| 9 to 15                                 | N/A                           | Reserved   |

**Frequency Command F (XXX.X)**

**h2102**

Status location for the frequency setting of the AC drive.

**Output Frequency H (XXX.X)**

**h2103**

Status location for the actual operating frequency present at the T1, T2, and T3 terminal.

**Output Current A**

**h2104**

Status location for the output current present at the T1, T2, and T3 terminals.

**DC-BUS Voltage d (XXX.X)**

**h2105**

Status location for the DC Bus Voltage.

|                                 |              |
|---------------------------------|--------------|
| <b>Output Voltage U (XXX.X)</b> | <b>h2106</b> |
|---------------------------------|--------------|

Status location for the output voltage present at the T1, T2, and T3 terminals.

|                  |              |
|------------------|--------------|
| <b>Motor RPM</b> | <b>h2107</b> |
|------------------|--------------|

Status location for the present estimated speed of the motor.

|                                   |              |
|-----------------------------------|--------------|
| <b>Scale Frequency (Low word)</b> | <b>h2108</b> |
|-----------------------------------|--------------|

Status location for result of output frequency x P 8.01 (low word).

|                                    |              |
|------------------------------------|--------------|
| <b>Scale Frequency (High word)</b> | <b>h2109</b> |
|------------------------------------|--------------|

Status location for result of output frequency x P 8.01 (high word).

|                           |              |
|---------------------------|--------------|
| <b>Power Factor Angle</b> | <b>h210A</b> |
|---------------------------|--------------|

Status location for the power factor angle.

|               |              |
|---------------|--------------|
| <b>% Load</b> | <b>h210B</b> |
|---------------|--------------|

Status location for the amount of load on the AC drive. (Output Current ÷ Drive Rated Current) x 100.

|                         |              |
|-------------------------|--------------|
| <b>Firmware Version</b> | <b>h2110</b> |
|-------------------------|--------------|

Status location for the firmware version of the AC drive.

# Communicating with *Direct*LOGIC PLCs

The following steps explain how to connect to and communicate with the GS2 Series AC drives using *Direct*LOGIC PLCs.

## Step 1: Choose the Appropriate CPU.

The GS2 Series AC drives will communicate with the following *Direct*LOGIC CPUs using Modbus communications:

- DL05      • DL06      • DL250(-1)
- DL260    • DL350    • DL450

## Step 2: Make the Connections

First you must decide what type of interface will work best for your application. The GS2 Comm Port can accommodate an RS-232C or an RS-485 connection.

### RS-232C

An RS-232C connection is somewhat limited. The maximum RS-232C network cable length is 15 meters (50 feet). In addition, using the RS-232C interface will allow you to connect an AC drive to only one PLC. For an RS-232C connection, set the GS2 DIP switches SW2 and SW3 to RS232.

RJ-12 (6P4C) Serial Comm Port

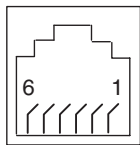

**RS-232C Interface**

- 2: GND
- 3: RXD
- 4: TXD
- 5: +5V

RS485

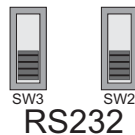

Switches SW2 and SW3 must be set to RS232 for an RS-232C connection.

Use the following wiring diagrams to connect your *Direct*LOGIC PLC to a GS2 Series AC drive with an RS-232C interface:

### DL05: RS-232C Connection Wiring

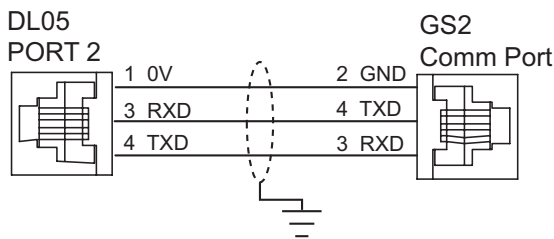

### DL350/DL450: RS-232C Connection Wiring

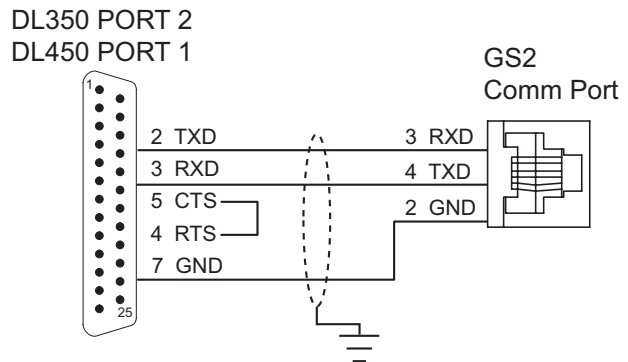

### DL06/DL250/DL260: RS-232C Connection Wiring

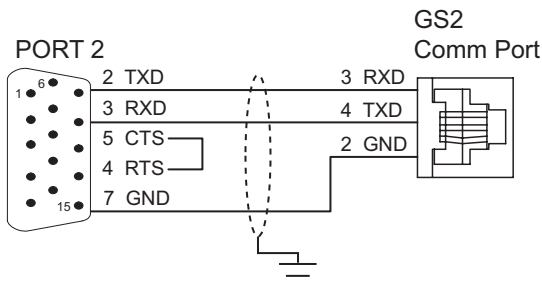

**RS-232C to RS-485 Conversion**

An RS-485 network cable can span up to 1000 meters (4000 feet). However, most **DirectLOGIC** PLCs require an FA-ISOCOCON (RS-232C to RS-422/485 network adapter) in order to make this type of connection. For an RS-485 connection, set the GS2 DIP switches SW2 and SW3 to RS485.

RJ-12 (6P4C) Serial Comm Port

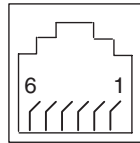

**RS-485 Interface**  
 2: GND  
 3: SG-  
 4: SG+  
 5: +5V

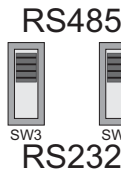

Switches SW2 and SW3 must be set to RS485 for an RS-485 connection.

Use the following wiring diagrams to connect your **DirectLOGIC** PLC to a GS2 Series AC drive with an RS-485 interface:



*Note: If an FA-ISOCOCON module is used in your connection, set the module dipswitches S21 = ON; S22 - S27 = OFF; TERMINATE, BIAS, and DPX = ON. Refer to FA-ISOCOCON manual for more detailed information.*

**DL05: RS-485 Connection Wiring**

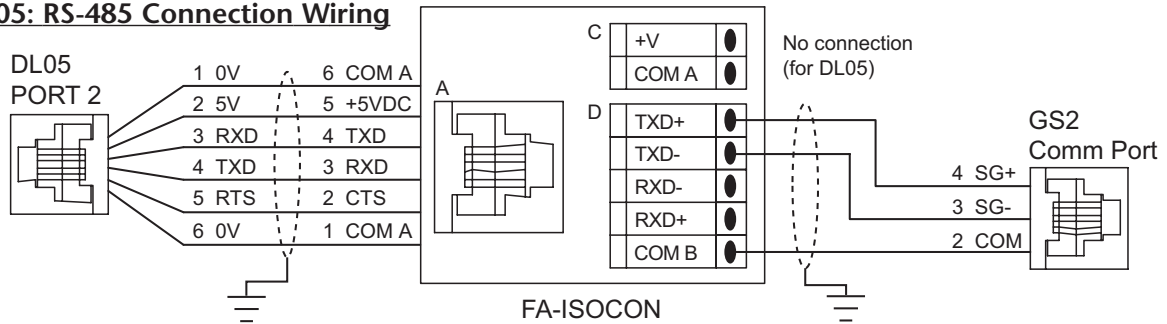

**DL250: RS-485 Connection Wiring**

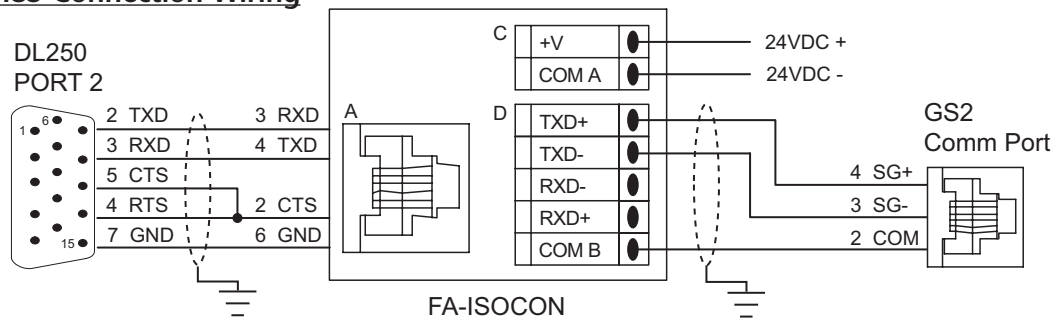

**DL350/DL450: RS-485 Connection Wiring**

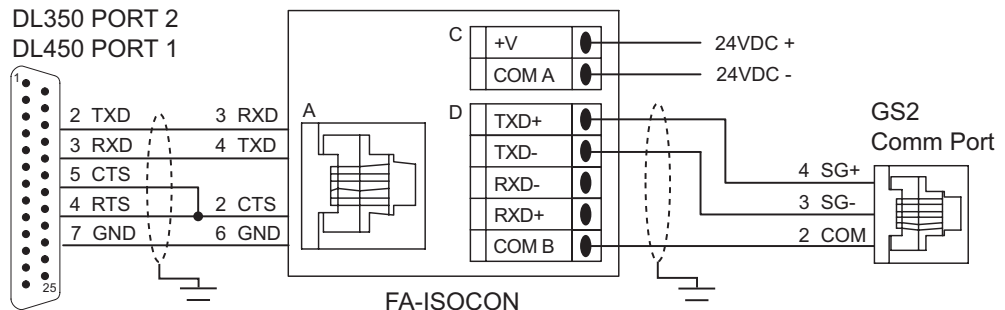

### RS-485

#### DL06/DL260: RS-485 Connection Wiring

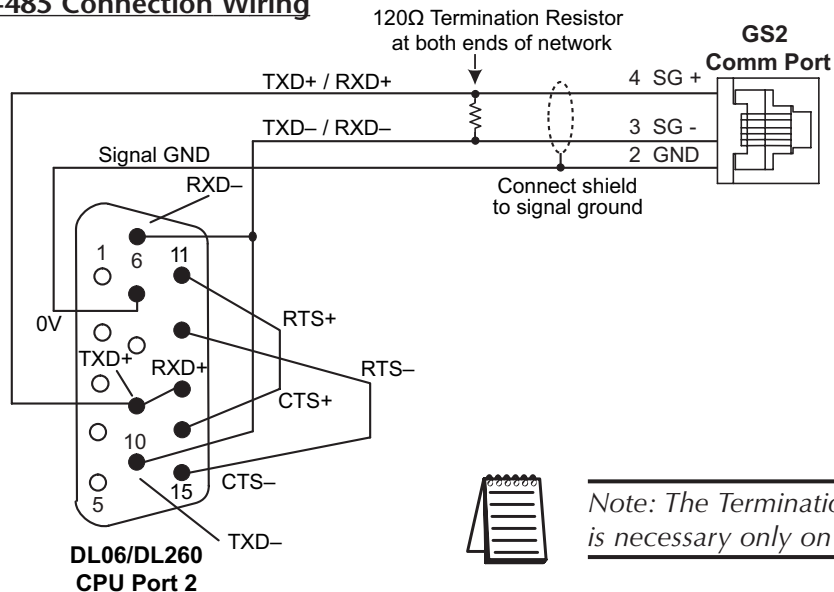

### Step 3: Set AC Drive Parameters

The following parameters need to be set as shown in order to communicate properly.

- P 3.00: 03 or 04 – Operation Determined by RS-232C/RS-485 interface. Keypad STOP is enabled (03) or disabled (04).
- P 4.00: 05 – Frequency determined by RS-232/RS-485 communication interface
- P 9.00: xx – Communication address 1-254 (unique for each device, see P 9.00)
- P 9.01: 01 – 9600 baud data transmission speed
- P 9.02: 05 – Modbus RTU mode <8 data bits, odd parity, 1 stop bit>



*Note: The previous list of parameter settings is the minimum required to communicate with a **DirectLOGIC** PLC. There may be other parameters that need to be set to meet the needs of your application.*

### Step 4: Configure the **DirectLOGIC** CPUs

The **DirectLOGIC** CPUs must be configured to communicate with the GS2 Series AC drives. This set up includes setting up the communication port and adding instructions to your logic program.

The set up for all of the **DirectLOGIC** CPUs is very similar. However, there may be some subtle differences between CPUs. Refer to the appropriate CPU User Manual for the specifics on your **DirectLOGIC** CPU.



*Note: For instructions on Modbus Configuration for your specific CPU, refer to the appropriate CPU User Manual.*

## DirectLOGIC Modbus Port Configuration

The following configuration example is specific to the DL250(-1) CPU. Refer to the appropriate CPU User Manual for the specifics on your **DirectLOGIC** CPU.

- In **DirectSOFT**, choose the PLC menu, then Setup, then “Secondary Comm Port”.
- From the **Port** list box, choose “Port 2”.
- For the protocol, select “Modbus”.

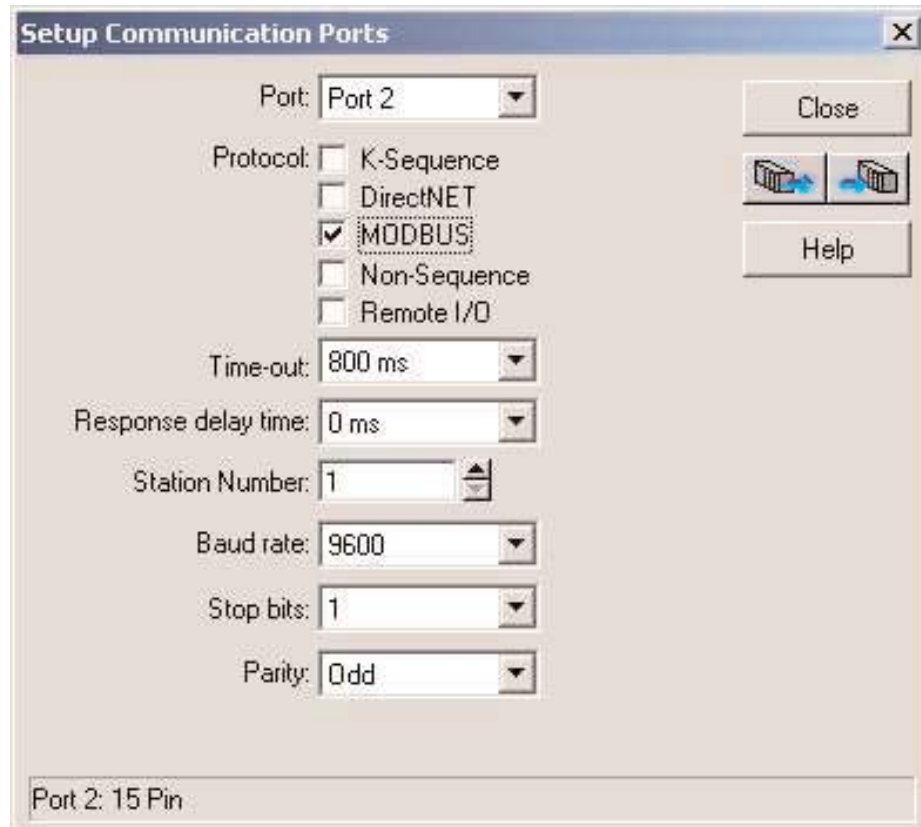

- In the **Timeout** list box, select “800 ms”.
- **Response Delay Time** should be “0 ms”.
- The **Station Number** should be set to “1” to make the DL250(-1) CPU a Modbus master.



*Note: The DL250(-1) network instructions used in Master mode will access only slaves 1 to 90. Each slave must have a unique number.*

- The **Baud Rate** should be set at “9600”.
- In the **Stop Bits** list box, choose “1”.
- In the **Parity** list box, choose “Odd”.

### DirectLOGIC Modbus Ladder Programming

The set up for all of the **Direct**LOGIC CPUs is very similar. However, there may be some subtle differences between CPUs. Refer to the appropriate CPU User Manual for the specifics on your **Direct**LOGIC CPU.

The following ladder program shows some examples of how to control the GS2 AC drive through Modbus RTU. The drive should be setup and tested for communications before it is connected to a load.



---

**WARNING: A drive should never be connected to a load until any applicable communication programs have been proven.**

---



---

*Note: This program is for illustration purposes only, and is not intended for a true application.*

---

In many drive applications, electromagnetic interference can sometimes cause frequent, short duration communication errors. Unless the application environment is perfect, an occasional communication error will occur. In order to distinguish between these non-fatal transients and a genuine communication failure, you may want to use the instructions as shown in Rungs 1 through 4.

Rung 1 monitors the number of times that the PLC attempts to communicate with the AC drive. When the PLC's communication attempts are successful, SP116 will count up, and SP117 will not count. Once the count reaches 9999, the counter will reset and resume counting.



---

*Note: SP116 and SP117 are special relays in the **Direct**LOGIC CPUs that monitor the PLC's communications. SP116 is on when Port 2 is communicating with another device. SP117 is on when Port 2 has encountered a communication error.*

---

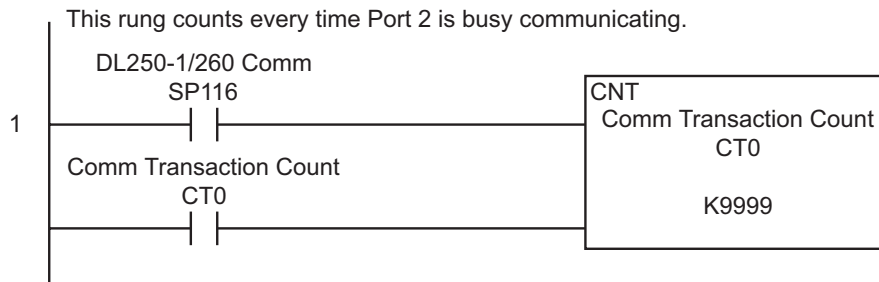

(Continued next page)



**DirectLOGIC Modbus Ladder Programming (cont.)**

Rungs 2 through 4 monitor the number of times the PLC fails in communicating with the AC drive. These instructions set the C0 control relay bit (to be used for alarm or shut-down) based on the number of times the SP117 bit is active in one minute. In this example, C0 will be set if the number of errors exceed 20 in one minute.

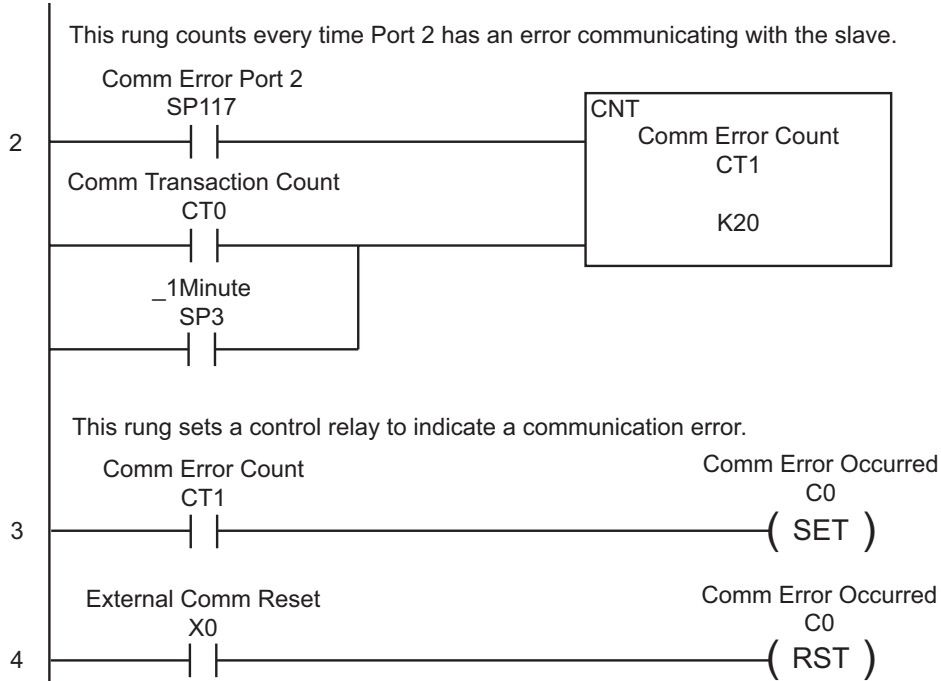

(Continued next page)

### DirectLOGIC Modbus Ladder Programming (cont.)

Rung 5 reads 12 of the status addresses of the GS2 AC drive. These instructions read the values from the GS2 status addresses, 2100 to 210B, and places the values into the PLC memory addresses, V2000 to V2013.

Notice the number in the RX box; V20400. 20400 is an **octal** number, as are all address references in the **DirectLOGIC** PLCs. 20400 octal converted to hex is 2100, which is the first status address for the GS2 AC drive.



*Note: Refer to your PLC User Manual for more specifics on Modbus addressing and address conversions.*

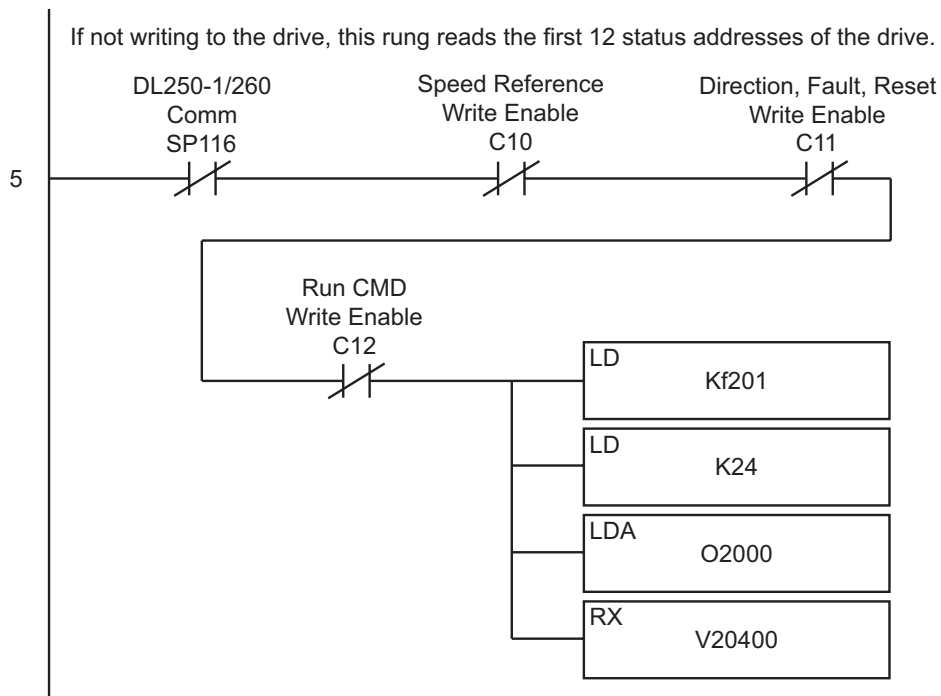

(Continued following “Alternate Modbus Read Instruction”)

**Alternate Modbus Read Instruction for DL06 and DL260 CPUs**

The DL06 and DL260 CPUs offer “Modbus Read from Network” and “Modbus Write to Network” instructions that are easier to use than are the “Read from Network” and “Write to Network” instructions of the other *Direct*LOGIC CPUs.

Rung 5, as shown below, reads the first 12 of the status addresses of the GS2 AC drive. This instruction reads the values from the GS2 status addresses, 2100 to 210B, and place the values into the PLC memory addresses V2000 to V2013.

The Start Slave Memory Address in the MRX box is 48449, which is a **Modbus decimal number (584/984 type)**. To convert 48449 decimal to hex, you first subtract 40001, and then convert the remainder to (hex) 2100. H2100 is the address for the GS2 Status Monitor.



*Note: Refer to your PLC User Manual for more specifics on Modbus addressing and address conversions.*

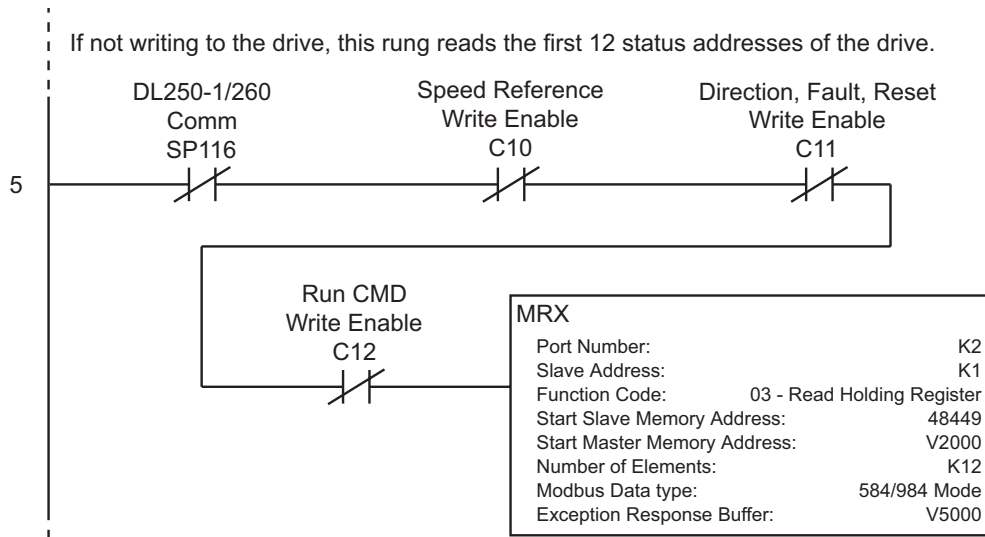

### DirectLOGIC Modbus Ladder Programming (cont.)

Rungs 6 through 9 show examples of how data read from the drive Status Addresses to set Control Relay bits that can be used for alarm or shut-down.

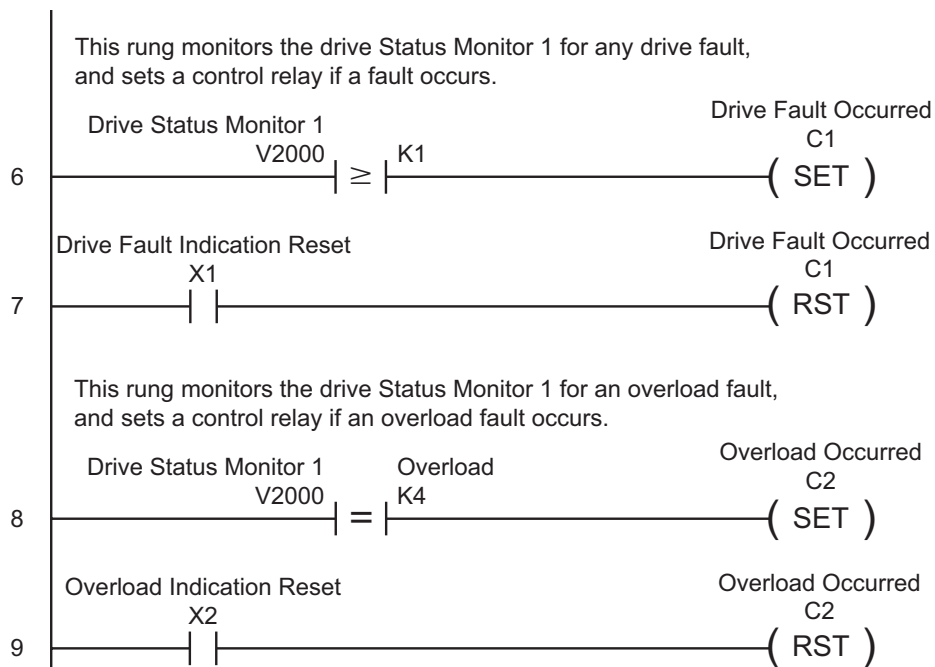

(Continued next page)

**DirectLOGIC Modbus Ladder Programming (cont.)**

Rung 10 monitors the Speed Reference, Direction, External Fault, and Fault Reset Commands for changes. If there are any changes, then a control relay is set to allow the Speed Reference to be written to the drive in the next rung. (This control relay is also used in later rungs to enable writes for the other three listed commands.)

The program monitors the commands for changes, and then writes to the drive only when there is a change. This procedure promotes safe machine operation by isolating the Run Command from the write block.

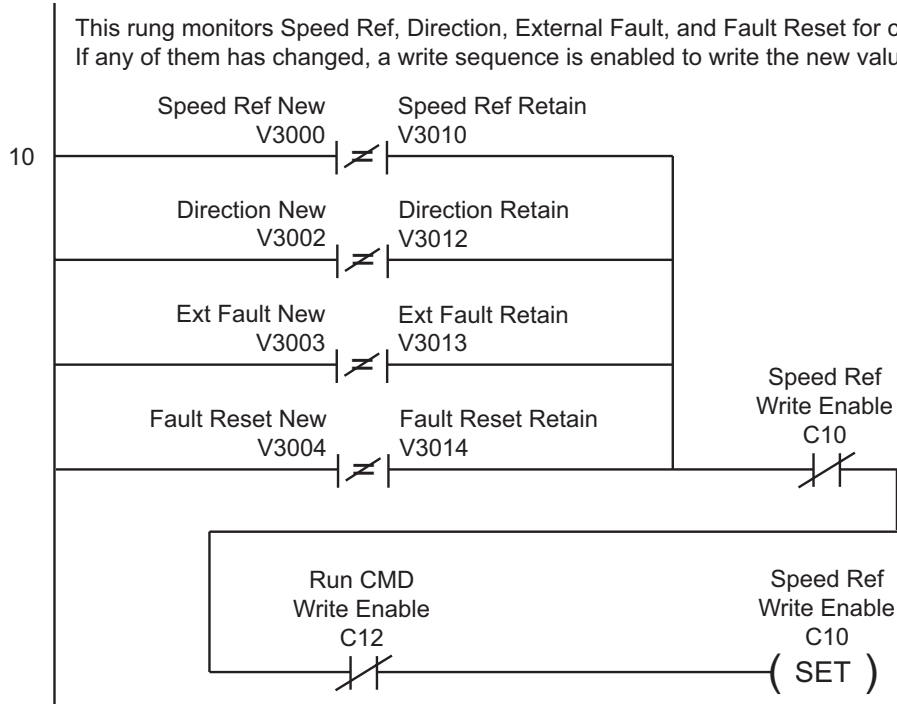

(Continued next page)

**DirectLOGIC Modbus Ladder Programming (cont.)**

Rungs 11 and 12 write the new Speed Reference, Direction, External Fault, and Fault Reset commands to the drive. We use two separate write commands in two separate rungs because the drive's Speed Reference command address (O4432) is not sequential with the Direction, External Fault, and Fault Reset command addresses (O4434 ~ O4436).

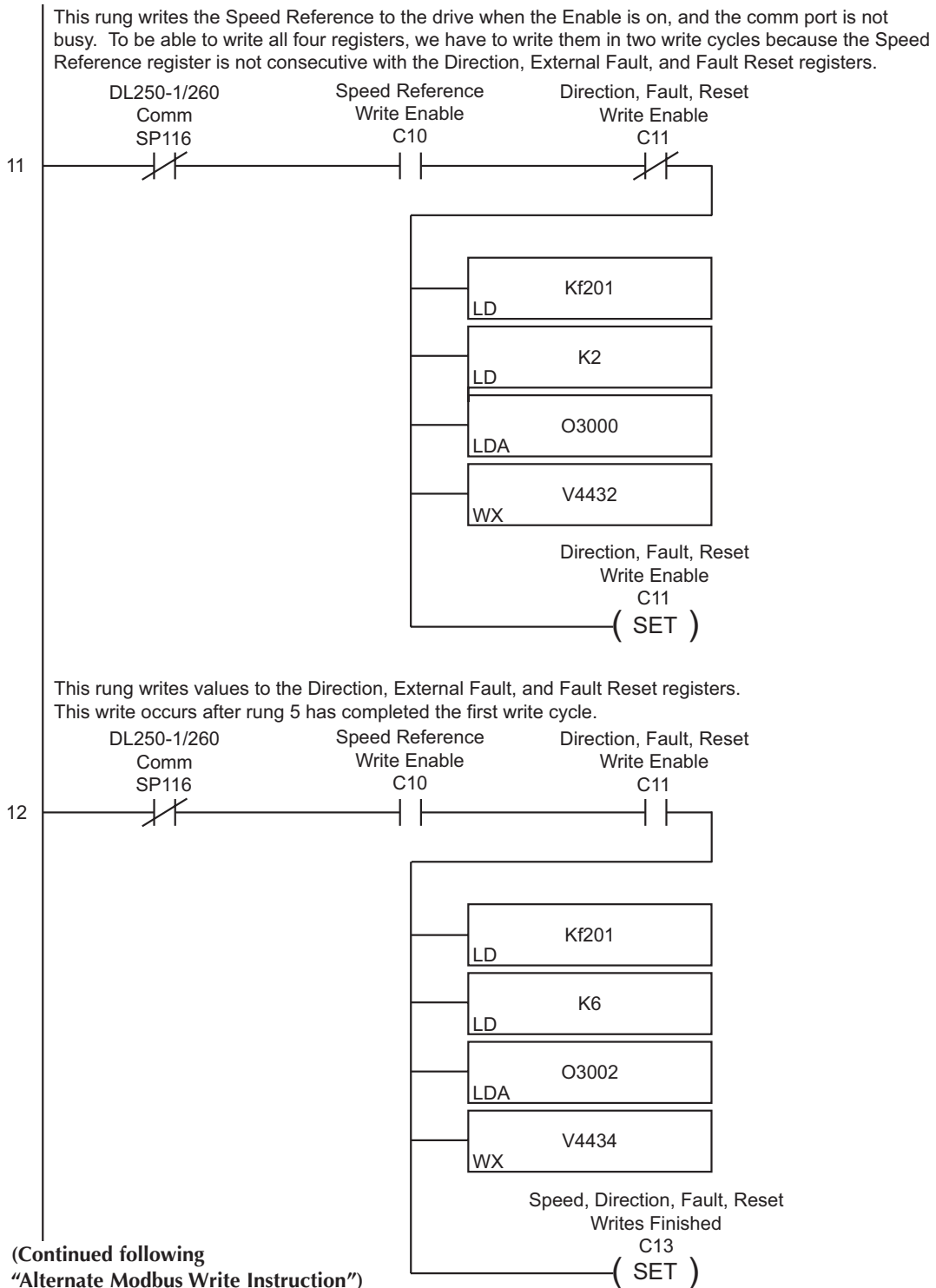

**Alternate Modbus Write Instruction for DL06 and DL260 CPUs**

The DL06 and DL260 CPUs offer “Modbus Read from Network” and “Modbus Write to Network” instructions that are easier to use than are the “Read from Network” and “Write to Network” instructions of the other *Direct*LOGIC CPUs.

Rungs 11, 12, and 15 write the V3000 Speed Reference, V3002 Direction, V3003 External Fault, V3004 Fault Reset, and V3001 Run values to the corresponding drive Modbus decimal addresses 42331, 42333, 42334, 42335, and 42332. In the first MWX box, the slave start memory address is 42331, which is a **Modbus decimal number (584/984 type)**. To convert 42311 decimal to hex, you first subtract 40001, and then convert the remainder to hex (91A). 91A is the address for the Serial Comm Speed Reference.



*Note: Refer to your PLC User Manual for more specifics on Modbus addressing and address conversions.*

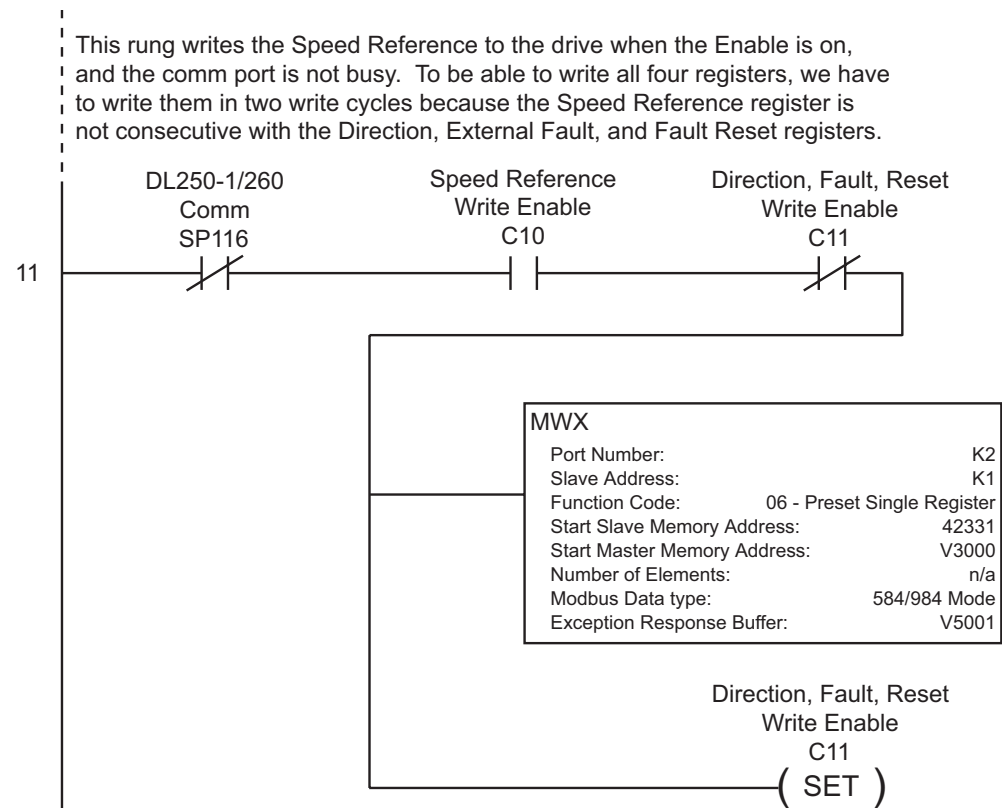

(Continued next page)

Alternate Modbus Write Instruction for DL06 and DL260 CPUs (cont.)

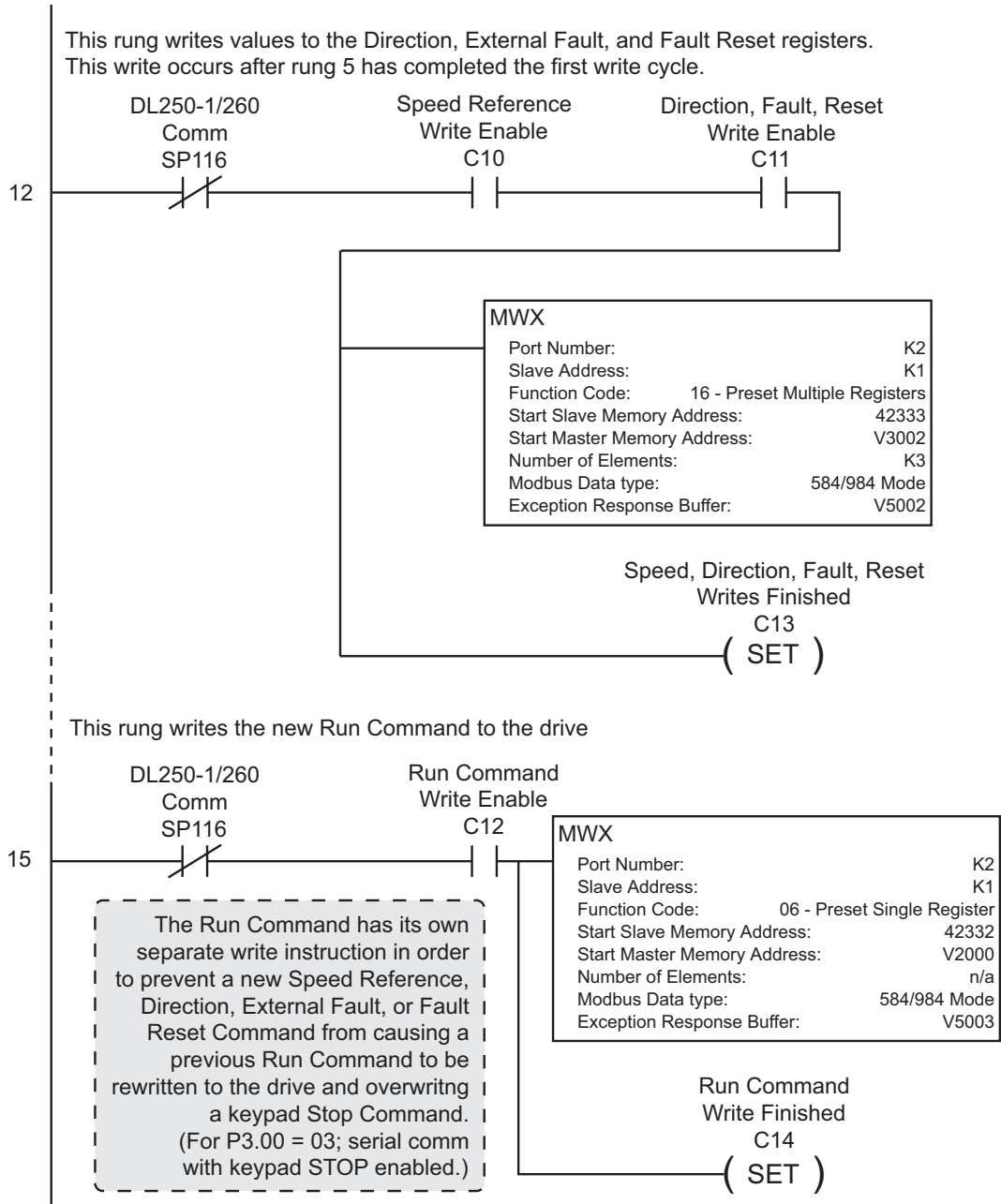



**DirectLOGIC Modbus Ladder Programming (cont.)**

Rung 13 loads the new Speed Reference, Direction, External Fault, and Fault Reset Command values into the retained value registers, and resets the applicable Write Enable control relays. Now the program is ready for the next command change detection and write to the drive.

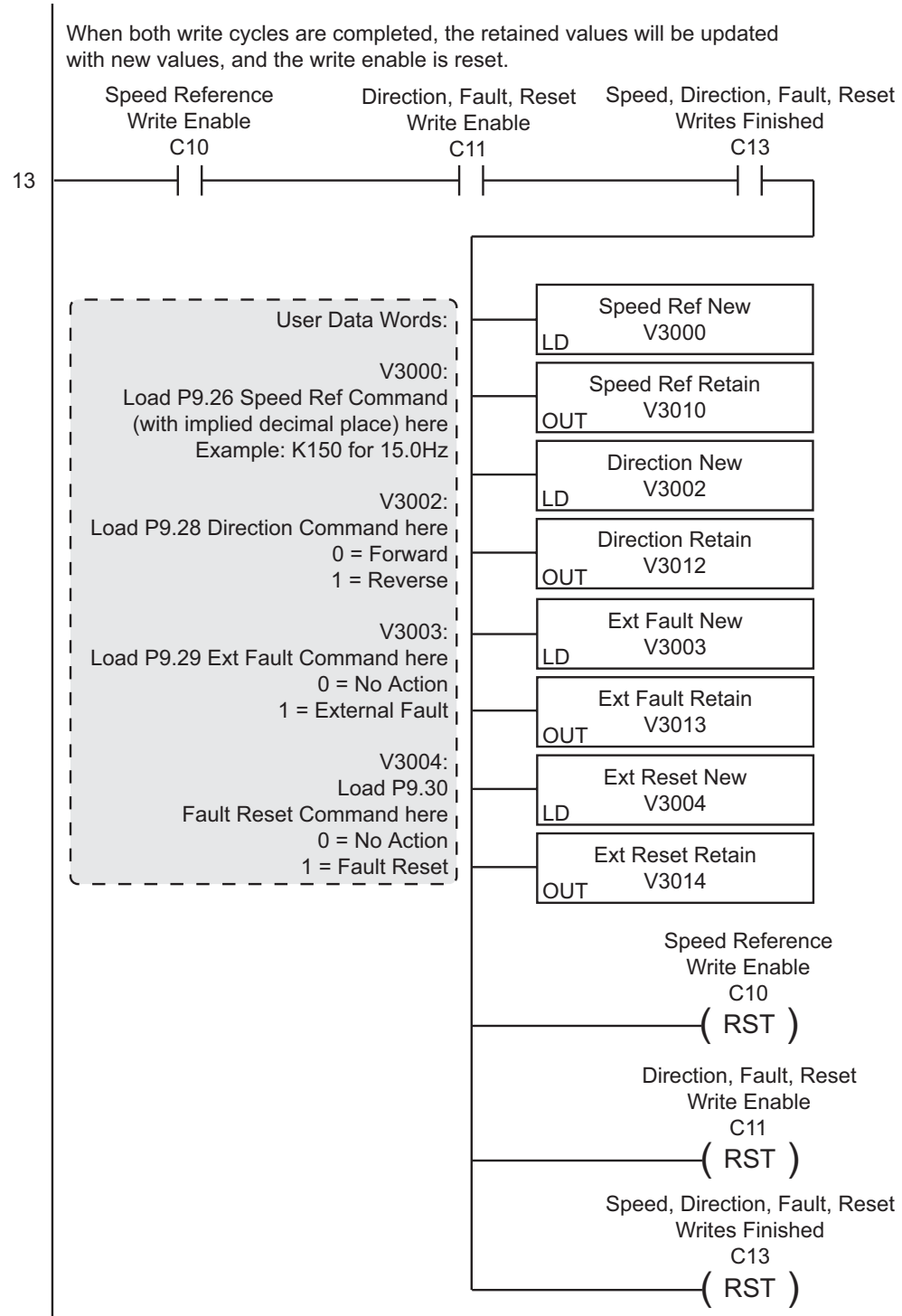

(Continued next page)

**DirectLOGIC Modbus Ladder Programming (cont.)**

Rungs 14 through 16 check for a Run Command change, write it to the drive, store the new value in the program register, and reset the enable control relays.

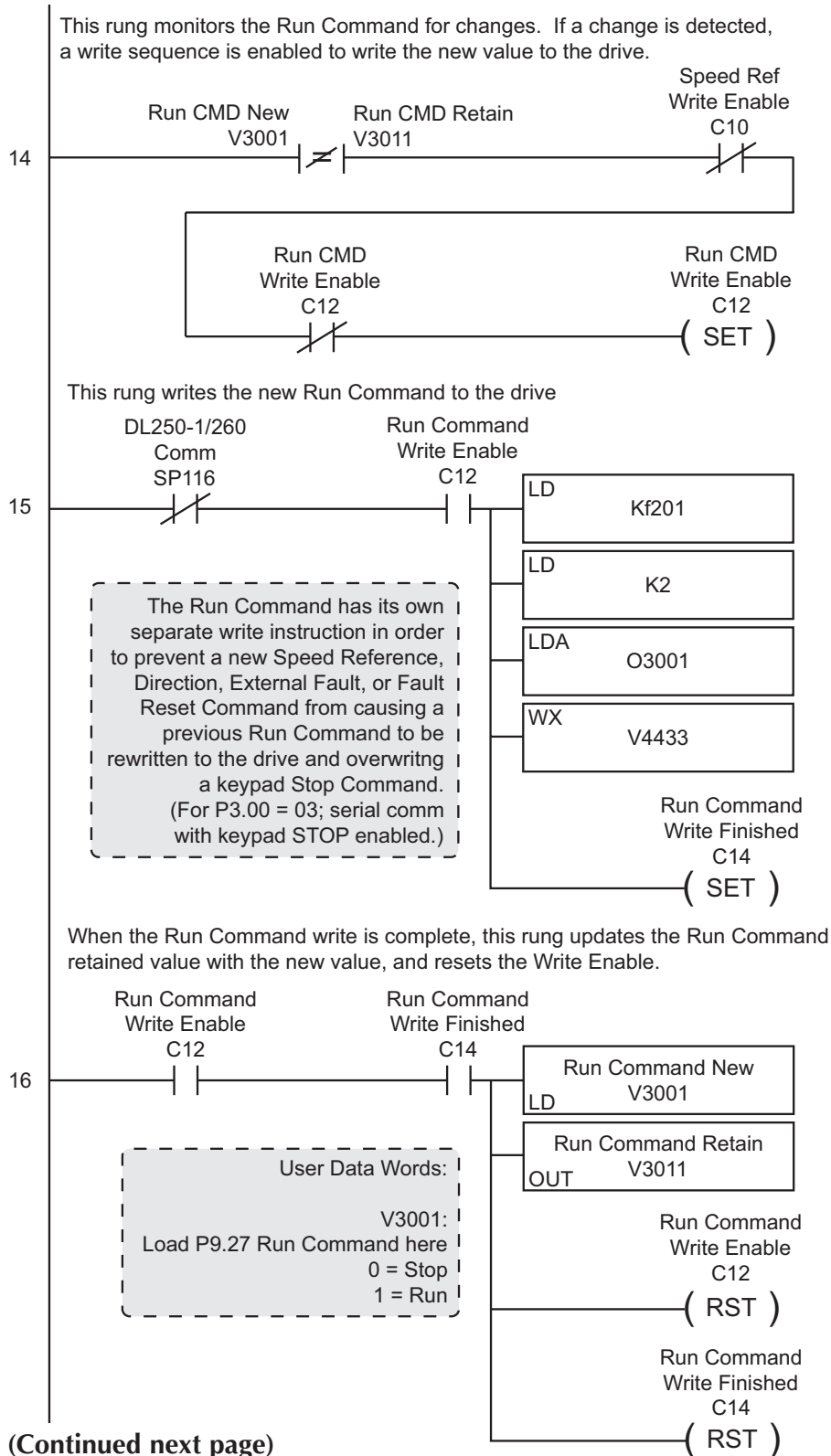

(Continued next page)

**DirectLOGIC Modbus Ladder Programming (cont.)**

Rungs 17 through 26 show an example of a method of inputting command values into the PLC.

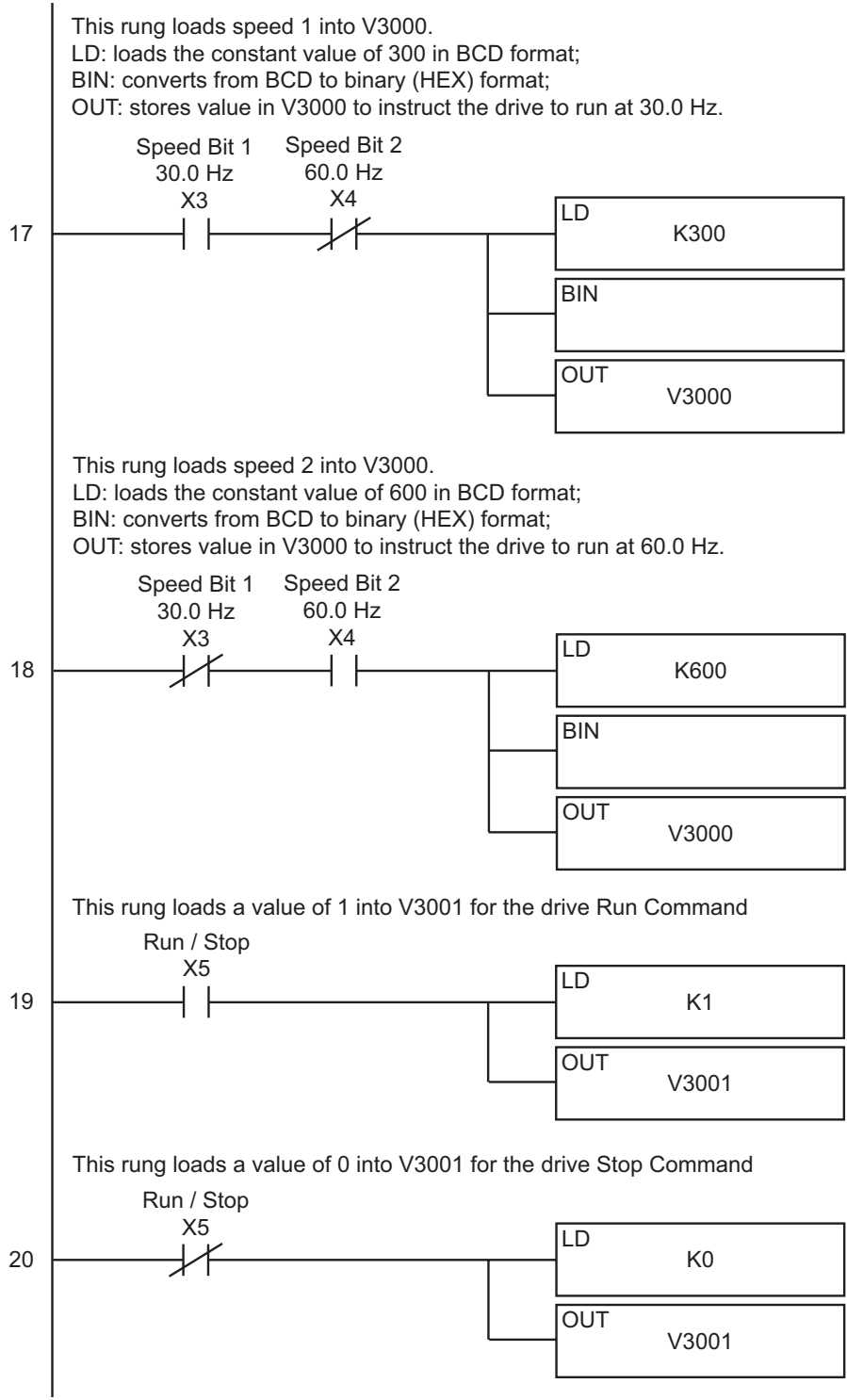

(Continued next page)

**DirectLOGIC Modbus Ladder Programming (cont.)**

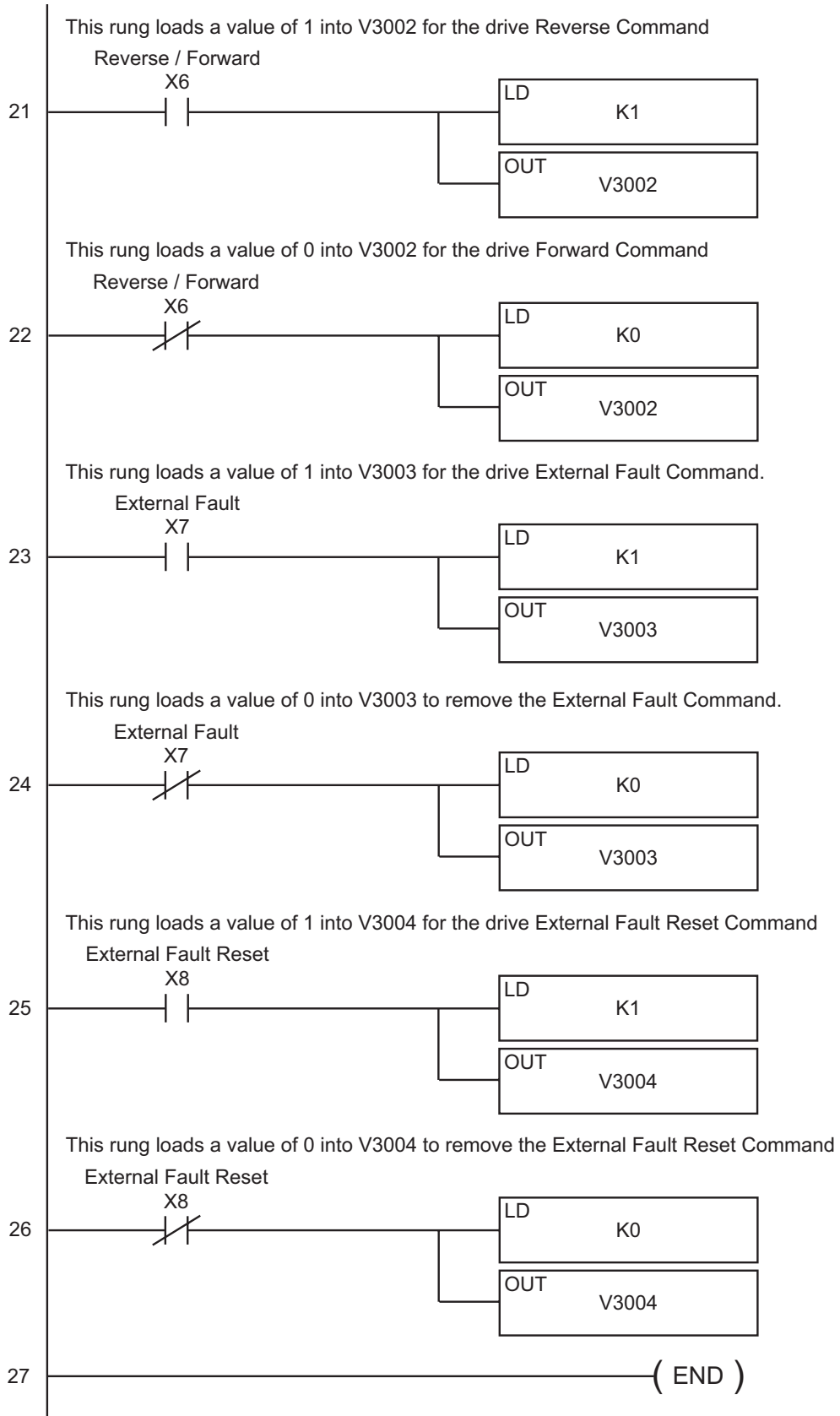

### **DirectLOGIC Modbus Ladder Programming (cont.)**

#### **Separate Run Command Write Instruction**

Why do we write the Run Command with a separate write instruction? If we write the Run Command to the drive along with the Speed Reference, Direction, External Fault, and Fault Reset Commands, we can keep the parameter addresses in sequence, and we can update all five of the commands with one write instruction. This method is valid **only** if we disable the drive's keypad STOP button (P3.00 = 04).

Typically, the keypad STOP button will be enabled (P3.00 = 03), and we need to prevent a change in one of the other commands from overriding a keypad Stop Command by causing a previous Run Command to be rewritten to the drive. By using a separate Run Command write instruction, only a deliberate Run Command change by the program will run the drive again after a stop.

#### **Block Transfer Parameters**

For writing to any of the parameters from P0.00 to P8.01, a group of 15 block transfer parameters (P9.11 to P9.25) is available in the GS2 AC drive. This sequential block of parameters can be used to "group" various miscellaneous non-sequential parameters, so that you can update the parameters in one programming write block instead of having to use multiple WX commands.

For example: If you need to change the PID setpoint (P7.11), accel time (P1.01), and multi-speed 1 (P5.01), this would typically take three different WX commands because the parameters are non-sequential. However, by setting P9.11 to P7.11, P9.12 to P1.01, and P9.13 to P5.01, the parameters become sequential, and can be controlled using one WX command (LD Kf201, LD K6, LDA Oxxxx, WX V4413).

## Communicating with Third-party Devices

First you must decide what type of interface will work best for your application. The GS2 RJ-12 Serial Comm Port can accommodate an RS232C or an RS-485 connection.

### RS-232C

An RS-232C connection is somewhat limited. The maximum network cable length for an RS-232C connection is 15 meters (50 feet). In addition, using the RS-232C interface will allow you to connect only one AC drive to one Modbus device. For an RS-232C connection, set the GS2 DIP switches SW2 and SW3 to RS232.

RJ-12 (6P4C) Serial Comm Port

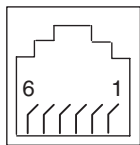

**RS-232C Interface**

- 2: GND
- 3: RXD
- 4: TXD
- 5: +5V

RS485

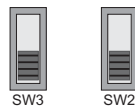

Switches SW2 and SW3 must be set to RS232 for an RS-232C connection.

### RS-485

An RS-485 network cable can span up to 1000 meters (4000 feet). For an RS-485 connection, set the GS2 DIP switches SW2 and SW3 to RS485.

RJ-12 (6P4C) Serial Comm Port

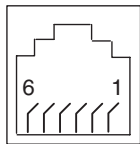

**RS-485 Interface**

- 2: GND
- 3: SG-
- 4: SG+
- 5: +5V

RS485



Switches SW2 and SW3 must be set to RS485 for an RS-485 connection.

The GS2 Series AC drive communication address is specified by P9.00. The third party device then controls each AC drive according to its communication address. The GS2 Series AC drive can be setup to communicate on standard Modbus networks using the following transmission modes: ASCII or RTU. Using the Communication Protocol parameter (P9.02), you can select the desired mode, data bits, parity, and stop bits. The mode and serial parameters must be the same for all devices on a Modbus network.

## Data Format

### ASCII Mode: 10-bit character frame (For 7-bit character):

P9.02 = 00 (7 data bits, no parity, 2 stop bits)

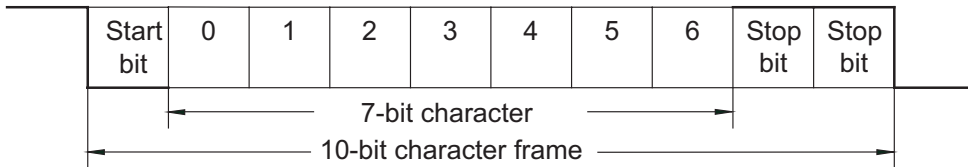

P9.02 = 01 (7 data bits, even parity, 1 stop bit)

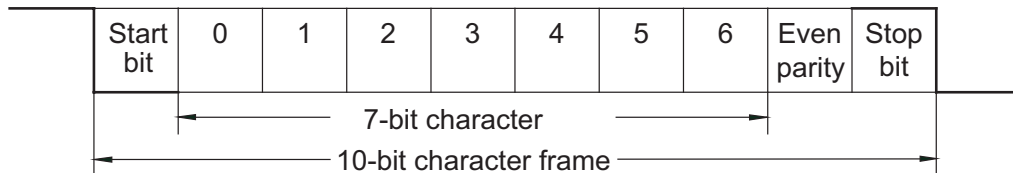

P9.02 = 02 (7 data bits, odd parity, 1 stop bit)

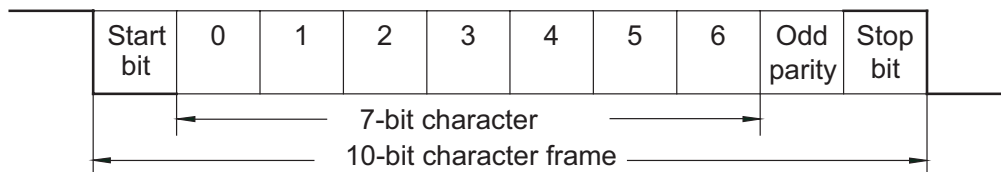

### RTU Mode: 11-bit character frame (For 8-bit character):

P9.02 = 03 (8 data bits, no parity, 2 stop bit)

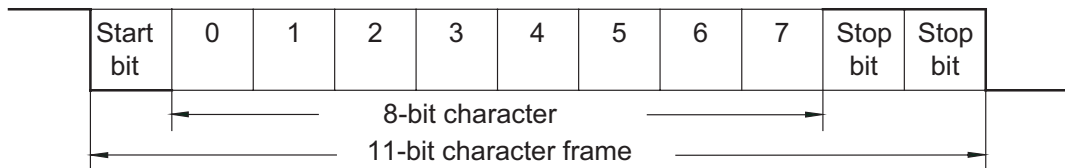

P9.02 = 04 (8 data bits, even parity, 1 stop bit)

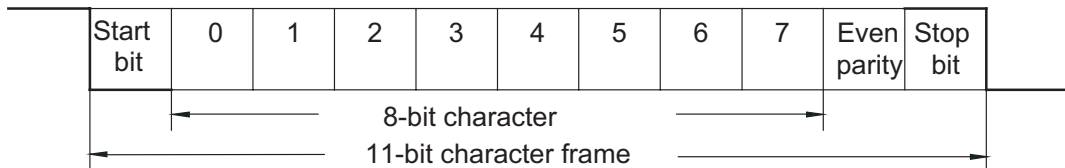

P9.02 = 05 (8 data bits, odd parity, 1 stop bit)

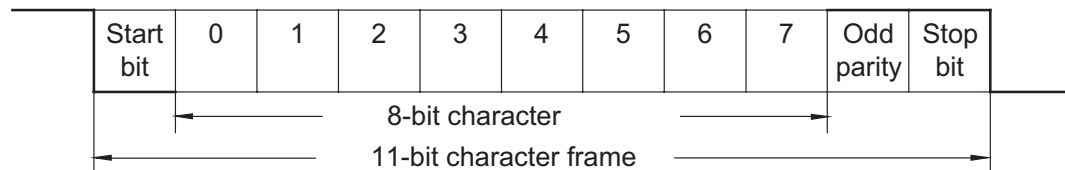

### Communication Protocol

#### ASCII Mode:

|            |  |
|------------|--|
| STX        | Start Character: (3AH)   |
| ADR 1      | Communication Address: 8-bit address consists of 2 ASCII codes                                   |
| ADR 0      |  |
| CMD 1      |  |
| CMD 0      |  |
| DATA (n-1) | Contents of data: n x 8-bit data consists of 2n ASCII codes. n ≤ 25<br>maximum of 50 ASCII codes |
| .....      |  |
| DATA 0     |  |
| LRC CHK 1  | LRC check sum: 8-bit check sum consists of 2 ASCII codes   |
| LRC CHK 0  |  |
| END 1      | END characters: END 1 = CR (0DH), END 0 = LF (0AH)   |
| END-0      |  |

#### RTU Mode:

|              |  |
|--------------|--|
| START        | A silent interval of more than 10 ms                           |
| ADR          | Communication Address: 8-bit address                           |
| CMD          | Command Code: 8-bit command                                    |
| DATA (n-1)   | Contents of data: n x 8-bit data, n ≤ 25                       |
| .....        |  |
| DATA 0       |  |
| CRC CHK Low  | CRC check sum: 16-bit check sum consists of 2 8-bit characters |
| CRC CHK High |  |
| END          | A silent interval of more than 10 ms                           |

#### ADR (Communication Address)

Valid communication addresses are in the range of 0 to 254. Communication address equals to 0 means broadcast to all AC drives, in which case the drives will not reply any message to the master device.

For example, communication to AC drive with address 16 decimal:

ASCII mode: (ADR 1, ADR 0)='1','0' => '1'=31H, '0'=30H

RTU mode: (ADR)=10H



**CMD (Command code) and DATA (data characters)**

The format of data characters depends on the command code. The available command codes are described as followed: Command code: 03H, read N words. The maximum value of N is 12. For example, reading continuous 2 words from starting address 2102H of the AC drive with address 01H.

**ASCII mode:**

| Command Message                |     | Response Message               |  |     |
|--------------------------------|-----|--------------------------------|--|-----|
| STX                            | '.' | STX '.'                        | '.'                                    |     |
| ADR 1                          | '0' | ADR 1                          | '0'                                    |     |
| ADR 0                          | '1' | ADR 0                          | '1'                                    |     |
| CMD 1                          | '0' | CMD 1                          | '0'                                    |     |
| CMD 0                          | '3' | CMD 0                          | '3'                                    |     |
| Starting data address          | '2' | Number of data (Count by byte) | '0'                                    |     |
|                                | '1' |                                | '4'                                    |     |
|                                | '0' |                                | Content of starting data address 2102H | '1' |
|                                | '2' |                                |  | '7' |
| '0'                            | '7' |                                |  |     |
| Number of data (Count by word) | '0' | Content data address 2103H     | '0'                                    |     |
|                                | '0' |                                | '0'                                    |     |
|                                | '0' |                                | '0'                                    |     |
|                                | '2' |                                | '0'                                    |     |
| LRC CHK 1                      | 'D' | LRC CHK 1                      | '7'                                    |     |
| LRC CHK 0                      | '7' |                                | LRC CHK 0                              | '1' |
| END 1                          | CR  | END 1                          |  | CR  |
| END 0                          | LF  | END 0                          | LF                                     |     |

**RTU mode:**

| Command Message                |     | Response Message               |              |
|--------------------------------|-----|--------------------------------|--------------|
| ADR                            | 01H | ADR                            | 01H          |
| CMD                            | 03H | CMD                            | 03H          |
| Starting data address          | 21H | Number of data (Count by byte) | 04H          |
|                                | 02H |                                | '0'          |
| Number of data (Count by word) | 00H | Content of data address 2102H  | 17H          |
|                                | 02H |                                | 70H          |
| CRC CHK Low                    | 6FH | Content of data address 2103H  | 00H          |
|                                | F7H |                                | 02H          |
| CRC CHK High                   | 6FH | CRC CHK Low                    | FEH          |
|                                | F7H |                                | CRC CHK High |

Command code: 06H, write 1 word

For example, writing 6000(1770H) to address 0100H of the AC drive with address 01H.

**ASCII mode:**

| Command Message |     | Response Message |     |
|-----------------|-----|------------------|-----|
| STX             | '.' | STX              | '.' |
| ADR 1           | '0' | ADR 1            | '0' |
| ADR 0           | '1' | ADR 0            | '1' |
| CMD 1           | '0' | CMD 1            | '0' |
| CMD 0           | '6' | CMD 0            | '6' |
| Data Address    | '0' | Data Address     | '0' |
|                 | '1' |                  | '1' |
|                 | '0' |                  | '0' |
|                 | '0' |                  | '0' |
|                 | '1' | Data Content     | '1' |
|                 | '7' |                  | '7' |
|                 | '7' |                  | '7' |
| '0'             | '0' |                  |     |
| LRC CHK 1       | '7' | LRC CHK 1        | '7' |
| LRC CHK 0       | '1' | LRC CHK 0        | '1' |
| END 1           | CR  | END 1            | CR  |
| END 0           | LF  | END 0            | LF  |

**RTU mode:**

This is an example of using function code 16 for writing to multiple registers.

| Command Message               |     | Response Message               |     |
|-------------------------------|-----|--------------------------------|-----|
| ADR                           | 01H | ADR                            | 01H |
| CMD                           | 10H | CMD                            | 10H |
| Starting data address         | 20H | Starting data address          | 20H |
|                               | 00H |                                | 00H |
| Number of registers           | 00H | Number of data (Count by word) | 00H |
|                               | 02H |                                | 02H |
| Byte count                    | 04H | CRC CHK Low<br>CRC CHK High    | 4AH |
| Content of data address 2000H | 00H |                                | 08H |
|                               |     | 02H                            |     |
| Content of data address 2001H | 02H |                                |     |
|                               | 58H |                                |     |
| CRC CHK Low<br>CRC CHK High   | CBH |                                |     |
|                               | 34H |                                |     |

CHK (check sum)

**ASCII Mode:**

LRC (Longitudinal Redundancy Check) is calculated by summing up module 256, the values of the bytes from ADR1 to last data character then calculating the hexadecimal representation of the 2's-complement negation of the sum.

For example, reading 1 word from address 0401H of the AC drive with address 01H.

| <b>Command Message</b>         |     |
|--------------------------------|-----|
| STX                            | ':' |
| ADR 1                          | '0' |
| ADR 0                          | '1' |
| CMD 1                          | '0' |
| CMD 0                          | '3' |
| Starting data address          | '0' |
|                                | '4' |
|                                | '0' |
|                                | '1' |
| Number of data (Count by word) | '0' |
|                                | '0' |
|                                | '0' |
|                                | '1' |
| LRC CHK 1                      | 'F' |
| LRC CHK 0                      | '6' |
| END 1                          | CR  |
| END 0                          | LF  |

---

$$01H+03H+04H+01H+00H+01H=0AH;$$

the 2's complement negation of 0AH is F6H.

---

**RTU Mode:**

| <b>Response Message</b>        |     |
|--------------------------------|-----|
| ADR                            | 01H |
| CMD                            | 03H |
| Starting data address          | 21H |
|                                | 02H |
| Number of data (Count by word) | 00H |
|                                | 02H |
| CRC CHK Low                    | 6FH |
| CRC CHK High                   | F7H |

CRC (Cyclical Redundancy Check) is calculated by the following steps:

- Step 1: Load a 16-bit register (called CRC register) with FFFFH.
- Step 2: Exclusive OR the first 8-bit byte of the command message with the low order byte of the 16-bit CRC register, putting the result in the CRC register.
- Step 3: Shift the CRC register one bit to the right with MSB zero filling. Extract and examine the LSB.
- Step 4: If the LSB of CRC register is 0, repeat step 3; else Exclusive OR the CRC register with the polynomial value A001H.
- Step 5: Repeat step 3 and 4 until eight shifts have been performed. When this is done, a complete 8-bit byte will have been processed.
- Step 6: Repeat steps 2 to 5 for the next 8-bit byte of the command message.

Continue doing this until all bytes have been processed. The final contents of the CRC register are the CRC value.



---

*Note: When transmitting the CRC value in the message, the upper and lower bytes of the CRC value must be swapped, i.e. the lower order byte will be transmitted first.*

---

The following is an example of CRC generation using C language. The function takes two arguments:

Unsigned char\* data ← a pointer to the message buffer  
Unsigned char length ← the quantity of bytes in the message buffer

The function returns the CRC value as a type of unsigned integer.

```
Unsigned int crc_chk(unsigned char* data, unsigned char length){
    int j;
    unsigned int reg_crc=0xFFFF;
    while(length--){
        reg_crc ^= *data++;
        for(j=0;j<8;j++){
            if(reg_crc & 0x01){ /* LSB(b0)=1 */
                reg_crc=(reg_crc>>1) ^ 0xA001;
            }else{
                reg_crc=reg_crc >>1;
            }
        }
    }
    return reg_crc;
}
```

# MAINTENANCE AND TROUBLESHOOTING

---



# CHAPTER 6

## In This Chapter...

|                                      |      |
|--------------------------------------|------|
| Maintenance and Inspection . . . . . | .6-2 |
| Monthly Inspection: . . . . .        | .6-2 |
| Annual Inspection . . . . .          | .6-2 |
| Troubleshooting . . . . .            | .6-3 |
| Fault Codes . . . . .                | .6-3 |
| Warning Messages . . . . .           | .6-6 |

# Maintenance and Inspection

Modern AC drives are based on solid state electronics technology. Preventive maintenance is required to operate the AC drive in its optimal condition, and to ensure a long life. It is recommended that a qualified technician perform a regular inspection of the AC drive. Some items should be checked once a month, and some items should be checked yearly. Before the inspection, always turn off the AC Input Power to the unit. Wait at least 2 minutes after all display lamps have turned off, and then confirm that the capacitors have fully discharged by measuring the voltage between B1 and Frame Ground using a multimeter set to measure DC voltage.



---

**WARNING! Disconnect AC power and ensure that the internal capacitors have fully discharged before inspecting the AC drive!**

---

### Monthly Inspection:

Check the following items at least once a month.

1. Make sure the motors are operating as expected.
2. Make sure the installation environment is normal.
3. Make sure the cooling system is operating as expected.
4. Check for irregular vibrations or sounds during operation.
5. Make sure the motors are not overheating during operation.
6. Check the input voltage of the AC drive and make sure the voltage is within the operating range. Check the voltage with a voltmeter.

### Annual Inspection

Check the following items once annually.

1. Tighten and reinforce the screws of the AC drive if necessary. They may loosen due to vibration or changing temperatures.
2. Make sure the conductors and insulators are not corroded and damaged.
3. Check the resistance of the insulation with mega-ohm meter.
4. Check the capacitors and relays; may require qualified repair shop to replace any defective components. Drive components are NOT field serviceable or replaceable.
5. Clean off any dust and dirt with a vacuum cleaner. Pay special attention to cleaning the ventilation ports, heat sinks, and PCBs. Always keep these areas clean. Accumulation of dust and dirt in these areas can cause unforeseen failures.

If the AC drive is not used for a long period of time, turn the power on at least once every two years and confirm that it still functions properly. To confirm functionality, disconnect the motor and energize the AC drive for 5 hours or more before attempting to run a motor with it.

## Troubleshooting

### Fault Codes

The AC drive has a comprehensive fault diagnostic system that includes several different alarms and fault messages. Once a fault is detected, the corresponding protective functions will be activated. The fault codes are then displayed on the digital keypad display. The six most recent faults can be read on the digital keypad display by viewing P6.31 to P6.36.



*NOTE: Faults can be cleared by a reset from the keypad or input terminal.*

| Fault Codes |   |  |
|-------------|---|--|
| Fault Name  | Fault Descriptions  | Corrective Actions   |
| <b>OC</b>   | The AC drive detects an abnormal increase in current.   | <ol style="list-style-type: none"> <li>1. Check whether the motor's horsepower corresponds to the AC drive output power.</li> <li>2. Check the wiring connections between the AC drive and motor for possible short circuits.</li> <li>3. Increase the Acceleration time (1-01 or 1-05).</li> <li>4. Check for possible excessive loading conditions at the motor.</li> <li>5. If there are any abnormal conditions when operating the AC drive after short-circuit is removed, the AC drive should be sent back to the manufacturer.</li> </ol> |
| <b>OU</b>   | The AC drive detects that the DC bus voltage has exceeded its maximum allowable value.  | <ol style="list-style-type: none"> <li>1. Check whether the input voltage falls within the rated AC drive input voltage.</li> <li>2. Check for possible voltage transients.</li> <li>3. Bus over-voltage may also be caused by motor regeneration. Either increase the decel time or add an optional braking resistor.</li> <li>4. Check whether the required braking power is within the specified limits.</li> </ol>   |
| <b>OH</b>   | The AC drive temperature sensor detects excessive heat.   | <ol style="list-style-type: none"> <li>1. Ensure that the ambient temperature falls within the specified temperature range.</li> <li>2. Make sure that the ventilation holes are not obstructed.</li> <li>3. Remove any foreign objects on the heat sinks and check for possible dirty heat sink fins.</li> <li>4. Provide enough spacing for adequate ventilation.</li> </ol>   |
| <b>LU</b>   | The AC drive detects that the DC bus voltage has fallen below its minimum value.  | Check whether the input voltage falls within the AC drive's rated input voltage.   |
| <b>OL</b>   | The AC drive detects excessive drive output current.<br>Note: The AC drive can withstand up to 150% of the rated current for a maximum of 60 seconds. | <ol style="list-style-type: none"> <li>1. Check whether the motor is overloaded.</li> <li>2. Reduce torque compensation setting as set in 2-03.</li> <li>3. Increase the AC drive's output capacity.</li> </ol>  |







| Fault Codes |  |   |
|-------------|--|---|
| Fault Name  | Fault Descriptions   | Corrective Actions  |
| <b>oL1</b>  | Internal electronic overload trip  | <ol style="list-style-type: none"> <li>1. Check for possible motor overload.</li> <li>2. Check electronic thermal overload setting.</li> <li>3. Increase motor capacity.</li> <li>4. Reduce the current level so that the AC drive output current does not exceed the value set by the Motor Rated Current 0-01.</li> </ol> |
| <b>oL2</b>  | Motor overload. Check the parameter settings (6-07 to 6-09)  | <ol style="list-style-type: none"> <li>1. Reduce the motor load.</li> <li>2. Adjust the over-torque detection setting to an appropriate level.</li> </ol>   |
| <b>ocA</b>  | Over-current during acceleration: <ol style="list-style-type: none"> <li>1. Short-circuit at motor output.</li> <li>2. Torque boost too high.</li> <li>3. Acceleration time too short.</li> <li>4. AC drive output capacity is too small.</li> </ol> | <ol style="list-style-type: none"> <li>1. Check for possible poor insulation at the output line.</li> <li>2. Decrease the torque boost setting in 2-03.</li> <li>3. Increase the acceleration time.</li> <li>4. Replace the AC drive with one that has a higher output capacity (next HP size).</li> </ol>                  |
| <b>ocd</b>  | Over-current during deceleration <ol style="list-style-type: none"> <li>1. Short-circuit at motor output.</li> <li>2. Deceleration time too short.</li> <li>3. AC drive output capacity is too small.</li> </ol>                                     | <ol style="list-style-type: none"> <li>1. Check for possible poor insulation at the output line.</li> <li>2. Increase the deceleration time.</li> <li>3. Replace the AC drive with one that has a higher output capacity (next HP size).</li> </ol>   |
| <b>ocn</b>  | Over-current during steady state operation: <ol style="list-style-type: none"> <li>1. Short-circuit at motor output.</li> <li>2. Sudden increase in motor loading.</li> <li>3. AC drive output capacity is too small.</li> </ol>                     | <ol style="list-style-type: none"> <li>1. Check for possible poor insulation at the output line.</li> <li>2. Check for possible motor stall.</li> <li>3. Replace the AC drive with one that has a higher output capacity (next HP size).</li> </ol>   |
| <b>cF1</b>  | Internal memory IC cannot be programmed.   | <ol style="list-style-type: none"> <li>1. Switch off power supply.</li> <li>2. Check whether the input voltage falls within the AC drive's rated input voltage.</li> <li>3. Switch the AC drive back on.</li> </ol>   |
| <b>cF2</b>  | Internal memory IC can not be read.  | <ol style="list-style-type: none"> <li>1. Check the connections between the main control board and the power board.</li> <li>2. Reset drive to factory defaults.</li> </ol>   |
| <b>HPF</b>  | Hardware protection failure  | Return to the factory.  |
| <b>code</b> | Software protection failure  | Return to the factory.  |
| <b>cF3</b>  | AC Drive's internal circuitry abnormal   | <ol style="list-style-type: none"> <li>1. Switch off power supply.</li> <li>2. Check whether the input voltage falls within the rated AC drive input voltage. Switch on the AC drive.</li> </ol>  |
| <b>EF</b>   | DI terminal EF-CM goes from OFF to ON, or 4-20mA AI signal is lost   | Remove EF-CM N.O. signal, restore EF-CM N.C. signal, or restore 4-20mA AI signal.   |
| <b>cFA</b>  | Auto accel/decel failure   | Don't use the function of auto acceleration/ deceleration.  |



| Fault Codes |   |  |
|-------------|---|--|
| Fault Name  | Fault Descriptions  | Corrective Actions   |
| <b>GFF</b>  | Ground fault :<br>The AC drive output is abnormal. When the output terminal is grounded (short circuit current is 50% more than the AC drive rated current), the AC drive power module may be damaged. The short circuit protection is provided for AC drive protection, not user protection. | Ground fault :<br>1. Check whether the IGBT power module is damaged.<br>2. Check for possible poor insulation at the output line.  |
| <b>bb</b>   | External Base Block:<br>AC drive output is turned off.  | 1. When the external input terminal (base-block) is active, the AC drive output will be turned off.<br>2. Disable this connection and the AC drive will begin to work again. |
| <b>PHL</b>  | Input Power 3 phase loss:<br>One phase of the input power is lost.  | 1. Check for possible poor connection on the input power line.<br>2. Check for possible loss of phase on input power line.   |

### Warning Messages

There are several Warning Messages that a GS2 AC Drive may give. The GS2 AC Drive allows you to decide its response to these messages. The descriptions of the Warning Messages are listed below.

| Warning Messages  |   |   |
|---|---|---|
| Warning Name  | Warning Descriptions  | Corrective Actions  |
|    | Communications Warning:<br>Illegal command code - The command code received in the command message is not available for the AC drive. | <p>The corrective action can be set with the Transmission Fault Treatment parameter (9-03). The available settings are:</p> <ul style="list-style-type: none"> <li>0 - Display fault and continue operating</li> <li>1 - Display fault and RAMP to stop</li> <li>2 - Display fault and COAST to stop</li> <li>3 - No fault displayed and continue operating</li> </ul> <p>The default setting is 0.</p> |
|    | Communications Warning:<br>Illegal data address - The data address received in the command message is not available for the AC drive. |   |
|    | Communications Warning:<br>Illegal data value - The data value received in the command message is not available for the AC drive.     |   |
|  | Communications Warning:<br>Slave device failure - The AC drive is unable to perform the requested action.                             |   |
|  | Communications Warning:<br>Communication Time Out   |   |
|  | PID Warning:<br>PID Feedback Loss - The 4-20mA PID signal has been lost.  |   |

# ACCESSORIES

---



## In This Appendix...

|   |      |
|---|------|
| Accessories Part Numbering . . . . .                | A-2  |
| Line Reactors . . . . .                             | A-2  |
| Line Reactor Dimensions . . . . .                   | A-4  |
| Line Reactor Applications and Connections . . . . . | A-5  |
| Braking Resistors . . . . .                         | A-8  |
| Braking Resistor Connections . . . . .              | A-8  |
| Braking Resistor Dimensions . . . . .               | A-9  |
| EMI Input Filters . . . . .                         | A-10 |
| EMI Filter Dimensions . . . . .                     | A-11 |
| EMI Filter Connections . . . . .                    | A-15 |
| RF Filters . . . . .                                | A-16 |
| Fuses and Fuse Kits . . . . .                       | A-17 |
| Fuses and Fuse Kits Dimensions . . . . .            | A-18 |
| GS-EDRV Ethernet Interface . . . . .                | A-20 |
| GS Drive Configuration Software . . . . .           | A-22 |
| System Requirements . . . . .                       | A-22 |
| Software Configuration Methods . . . . .            | A-22 |
| Miscellaneous Accessories . . . . .                 | A-25 |
| Configuration Cable . . . . .                       | A-25 |
| Spare Keypad . . . . .                              | A-25 |
| Keypad Cables . . . . .                             | A-25 |
| Communication Distribution Blocks . . . . .         | A-26 |

## Accessories Part Numbering

With the exception of EMI Filters, RF Filters, and some Line Reactors, GS2 Series accessory part numbers incorporate the part numbers of the AC Drives for which they are compatible. Each accessory part number begins with the AC Drive series and rating. This is followed by an accessory code, and, when applicable, a description code. The accessory part numbering scheme is shown below.

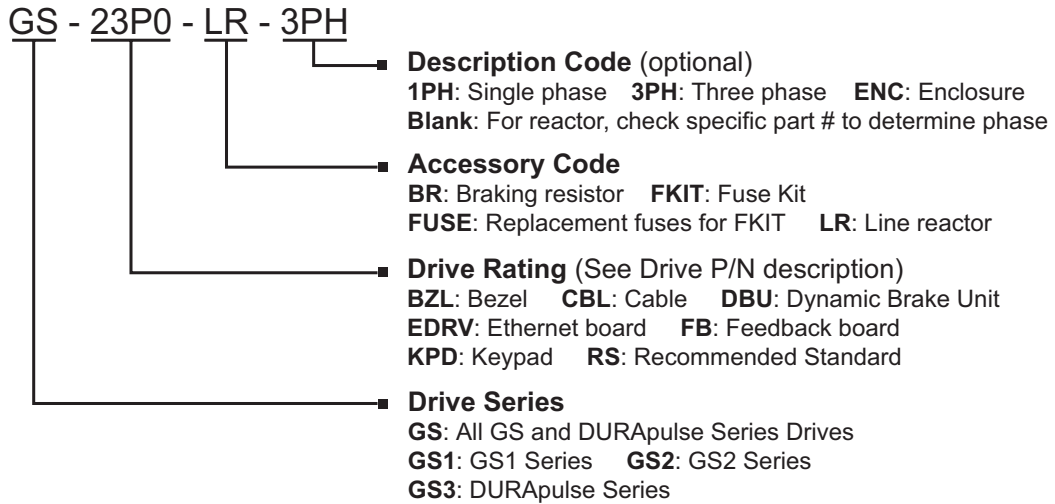

## Line Reactors

Input line reactors protect the AC drive from transient overvoltage conditions typically caused by utility capacitor switching. Input line reactors also reduce the harmonics associated with AC drives, and are recommended for all installations.

Output line (load) reactors protect the motor insulation against AC drive short circuits and IGBT reflective wave damage, and also allow the motor to run cooler by “smoothing” the motor current waveform. They are recommended for operating “non-inverter-duty” motors, and for any motors when the length of wiring between the AC drive and motor exceeds 75 feet.

| 115V Single Phase Input Line Reactors* |            |           |            |           |  |          |
|--|------------|-----------|------------|-----------|--|----------|
| Part Number                            | Rated Amps | Impedance | Inductance | Watt Loss | GS2 Drive Model and Side / Phase / Volts | Drive hp |
| GS-10P2-LR                             | 18         | 3%        | 0.80 mH    | 19        | GS2-10P2 (input) / 1ph / 115V            | 0.25     |
| GS-10P5-LR                             | 25         | 3%        | 0.50 mH    | 23        | GS2-10P5 (input) / 1ph / 115V            | 0.5      |
| GS-11P0-LR                             | 35         | 3%        | 0.40 mH    | 36        | GS2-11P0 (input) / 1ph / 115V            | 1        |

*\*NOTE: Single phase line reactors should NOT be installed on the output side of the AC drive.*

## Line Reactors (continued)

| 230V Single Phase Input Line Reactors* |            |           |            |           |  |          |
|--|------------|-----------|------------|-----------|--|----------|
| Part Number                            | Rated Amps | Impedance | Inductance | Watt Loss | GS2 Drive Model and Side / Phase / Volts | Drive hp |
| GS-20P5-LR-1PH                         | 8          | 3%        | 6.50 mH    | 13        | GS2-20P5 (input) / 1ph / 230V            | 0.5      |
| GS-21P0-LR-1PH                         | 12         | 3%        | 6.50 mH    | 13        | GS2-21P0 (input) / 1ph / 230V            | 1        |
| GS-22P0-LR-1PH                         | 18         | 3%        | 3.00 mH    | 25        | GS2-22P0 (input) / 1ph / 230V            | 2        |
| GS-23P0-LR-1PH                         | 35         | 3%        | 2.50 mH    | 26        | GS2-23P0 (input) / 1ph / 230V            | 3        |

**\*NOTE: Single phase line reactors should NOT be installed on the output side of the AC drive.**

| 230V Three Phase Input / Output Line Reactors |            |           |            |           |  |          |
|---|------------|-----------|------------|-----------|--|----------|
| Part Number                                   | Rated Amps | Impedance | Inductance | Watt Loss | GS2 Drive Model and Side / Phase / Volts | Drive hp |
| GS-20P5-LR-3PH                                | 4          | 3%        | 6.50 mH    | 13        | GS2-20P5 (in/out) / 3ph / 230V           | 0.5      |
| GS-21P0-LR-3PH                                | 4          | 3%        | 3.00 mH    | 7         | GS2-21P0 (in/out) / 3ph / 230V           | 1        |
| GS-22P0-LR-3PH                                | 8          | 3%        | 1.50 mH    | 11        | GS2-22P0 (in/out) / 3ph / 230V           | 2        |
| GS-23P0-LR-3PH                                | 12         | 3%        | 1.30 mH    | 23        | GS2-23P0 (in/out) / 3ph / 230V           | 3        |
| GS-25P0-LR                                    | 18         | 3%        | 0.80 mH    | 19        | GS2-25P0 (in/out) / 3ph / 230V           | 5        |
| GS-27P5-LR                                    | 25         | 3%        | 0.50 mH    | 23        | GS2-27P5 (in/out) / 3ph / 230V           | 7.5      |

| 460V & 575V Three Phase Input / Output Line Reactors |            |           |            |           |  |                  |
|--|------------|-----------|------------|-----------|--|------------------|
| Part Number  | Rated Amps | Impedance | Inductance | Watt Loss | GS2 Drive Model and Side / Phase / Volts   | Drive hp         |
| GS-41P0-LR   | 2          | 3%        | 12.0 mH    | 7         | GS2-41P0 (in/out) / 3ph / 460V   | 1                |
| GS-42P0-LR   | 4          | 3%        | 6.50 mH    | 13        | GS2-42P0 (in/out) / 3ph / 460V<br>GS2-53P0 (in/out) / 3ph / 575V                                   | 2<br>3           |
| GS-43P0-LR   | 8          | 3%        | 5.00 mH    | 31        | GS2-43P0 (in/out) / 3ph / 460V<br>GS2-55P0 (in/out) / 3ph / 575V                                   | 3<br>5           |
| GS-45P0-LR   | 8          | 3%        | 3.00 mH    | 25        | GS2-45P0 (in/out) / 3ph / 460V   | 5                |
| GS-47P5-LR   | 12         | 3%        | 2.50 mH    | 26        | GS2-47P5 (in/out) / 3ph / 460V<br>GS2-57P5 (in/out) / 3ph / 575V<br>GS2-5010 (in/out) / 3ph / 575V | 7.5<br>7.5<br>10 |
| GS-4010-LR   | 18         | 3%        | 1.50 mH    | 29        | GS2-4010 (in/out) / 3ph / 460V   | 10               |
| GS-51P0-LR   | 2          | 3%        | 20.0 mH    | 9         | GS2-51P0 (in/out) / 3ph / 575V   | 1                |
| GS-52P0-LR   | 4          | 3%        | 9.10 mH    | 15        | GS2-52P0 (in/out) / 3ph / 575V   | 2                |

### Line Reactor Dimensions

| AC Line Reactor Dimensions (inches) |      |      |      |        |        |                    |              |
|-------------------------------------|------|------|------|--------|--------|--------------------|--------------|
| Part Number                         | H    | W    | D    | Mtg. D | Mtg. W | Mtg Slot Hole Size | Weight (lbs) |
| GS-10P2-LR                          | 4.80 | 6.00 | 3.30 | 2.09   | 2.00   | 0.28 x 0.63        | 7            |
| GS-10P5-LR                          | 5.70 | 6.00 | 3.09 | 2.09   | 3.00   | 0.28 x 0.63        | 7            |
| GS-11P0-LR                          | 5.70 | 6.00 | 3.34 | 2.34   | 3.00   | 0.28 x 0.63        | 9            |
| GS-20P5-LR-1PH                      | 3.40 | 4.40 | 2.83 | 1.77   | 1.44   | 0.28 x 0.63        | 2.80         |
| GS-20P5-LR-3PH                      | 3.40 | 4.40 | 2.83 | 1.77   | 1.44   | 0.28 x 0.63        | 2.80         |
| GS-21P0-LR-1PH                      | 3.40 | 4.40 | 2.83 | 1.77   | 1.44   | 0.28 x 0.63        | 2.80         |
| GS-21P0-LR-3PH                      | 3.40 | 4.40 | 2.83 | 1.77   | 1.44   | 0.28 x 0.63        | 2.30         |
| GS-22P0-LR-1PH                      | 3.40 | 4.40 | 2.83 | 1.77   | 2.00   | 0.28 x 0.63        | 3.10         |
| GS-22P0-LR-3PH                      | 3.40 | 4.40 | 2.83 | 1.77   | 2.00   | 0.28 x 0.63        | 2.80         |
| GS-23P0-LR-1PH                      | 4.80 | 6.00 | 3.30 | 2.09   | 2.00   | 0.28 x 0.63        | 7.50         |
| GS-23P0-LR-3PH                      | 3.40 | 4.40 | 2.83 | 1.77   | 2.00   | 0.28 x 0.63        | 2.90         |
| GS-25P0-LR                          | 4.80 | 6.00 | 3.30 | 2.09   | 2.00   | 0.28 x 0.63        | 7.10         |
| GS-27P5-LR                          | 5.70 | 6.00 | 3.09 | 2.09   | 3.00   | 0.28 x 0.63        | 7.00         |
| GS-41P0-LR                          | 3.40 | 4.40 | 2.83 | 1.77   | 1.44   | 0.28 x 0.63        | 2.30         |
| GS-42P0-LR                          | 3.40 | 4.40 | 2.83 | 1.77   | 1.44   | 0.28 x 0.63        | 2.80         |
| GS-43P0-LR                          | 3.40 | 4.40 | 3.39 | 2.39   | 2.00   | 0.28 x 0.63        | 4.30         |
| GS-45P0-LR                          | 3.40 | 4.40 | 2.83 | 1.77   | 2.00   | 0.28 x 0.63        | 3.10         |
| GS-47P5-LR                          | 4.80 | 6.00 | 3.30 | 2.09   | 2.00   | 0.28 x 0.63        | 7.50         |
| GS-4010-LR                          | 4.80 | 6.30 | 3.55 | 2.34   | 2.00   | 0.28 x 0.63        | 9.10         |
| GS-51P0-LR                          | 3.40 | 4.40 | 2.83 | 1.77   | 1.44   | 0.28 x 0.63        | 3            |
| GS-52P0-LR                          | 3.40 | 4.40 | 3.33 | 2.37   | 1.44   | 0.28 x 0.63        | 3            |

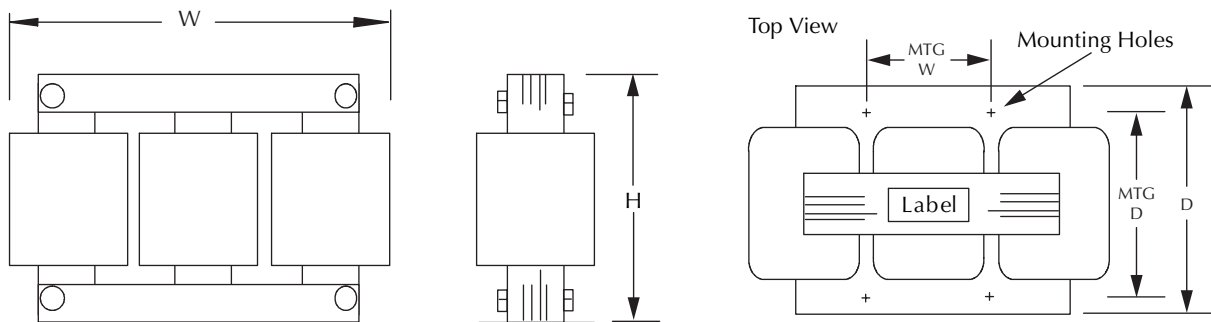

AC Line Reactor Dimensions

## Line Reactor Applications and Connections

### Input Side of AC Drive

When installed on the input side of the AC Drive, line reactors will reduce line notching, and limit current and voltage spikes and surges from the incoming line. The line reactors will also reduce harmonic distortion from the AC Drive onto the line. Units are installed in front of the AC Drive as shown.

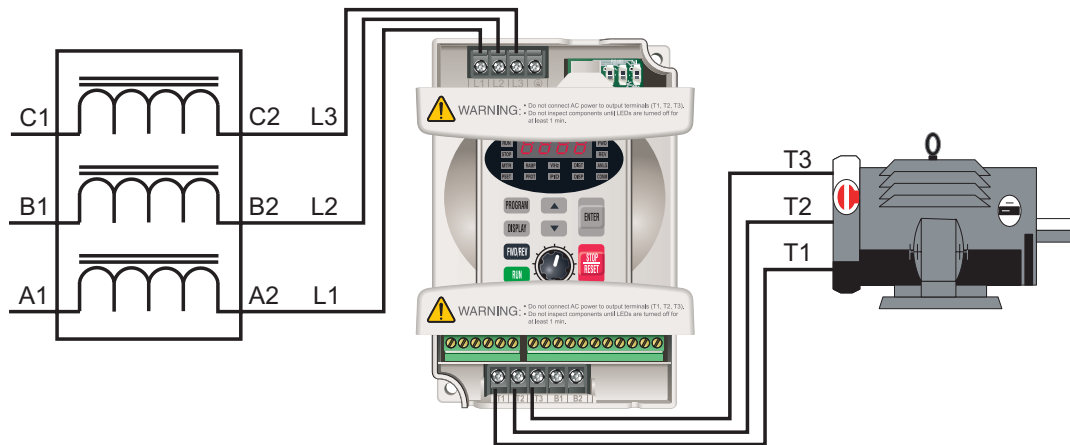

### Output Side of AC Drive

When installed on the output side of the AC Drive, line reactors protect the drive from short circuits at the load. Voltage and current waveforms from the drive are enhanced, reducing motor overheating and noise emissions.

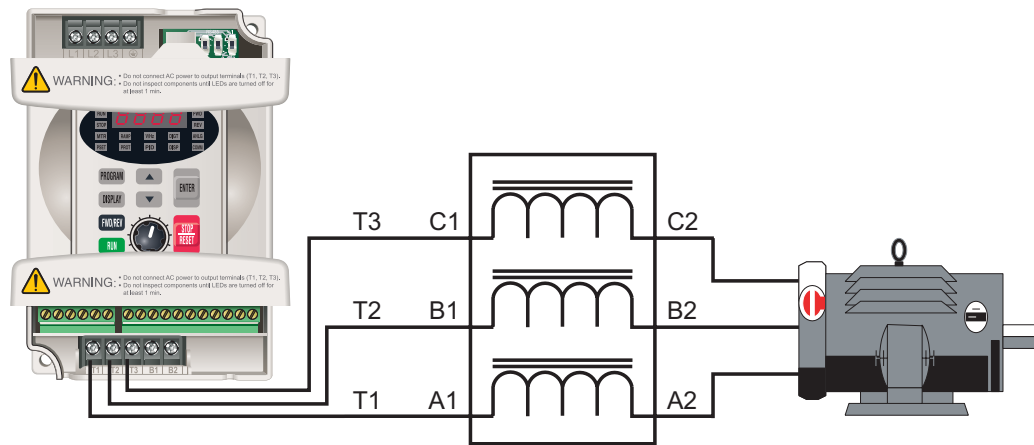

*Single-phase line reactors should NOT be installed on the output of the AC Drive. Use only three-phase reactors on drive outputs.*

## Line Reactor Applications and Connections (continued)

### Multiple AC Drives

Individual line reactors are recommended when installing multiple AC Drives on the same power line. Individual line reactors eliminate cross-talk between multiple drives, and provide isolated protection for each drive for its own specific load.

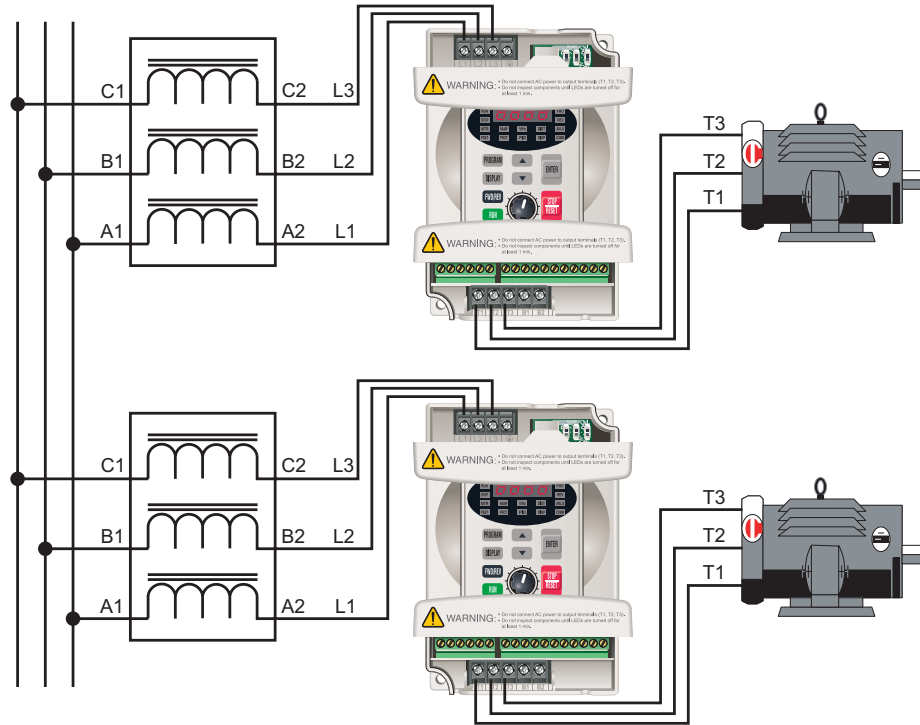

### Multiple Motors

A single reactor can be used when the application calls for multiple motors on the same AC Drive, if the motors operate simultaneously. The reactor is sized based on the total horsepower of all the motors. **Overload relays** (not shown) are recommended for use in multi-motor applications.

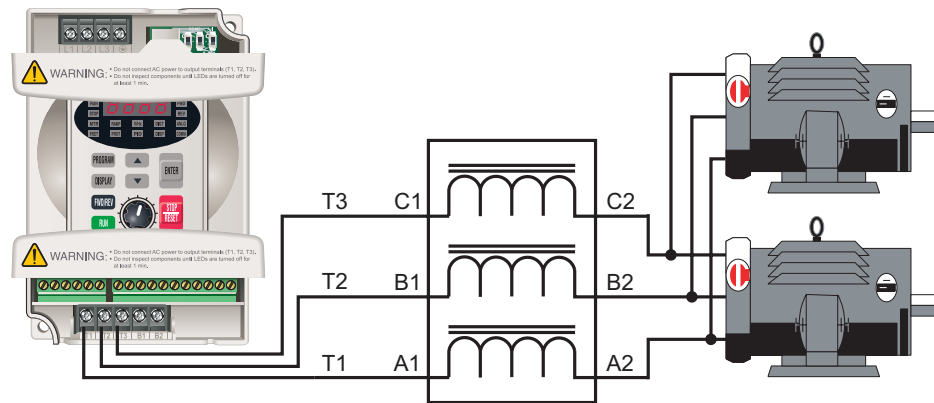

*A single reactor should be used with multiple motors ONLY when the motors will operate simultaneously. OVERLOAD RELAYS are recommended for use in multiple motor applications.*



## Line Reactor Applications and Connections (continued)

### Single-Phase Applications

Some of the line reactors are listed for use with single-phase input power. Follow the connection diagram shown below. Make sure that terminals B1 and B2 are properly insulated before any connections are made.

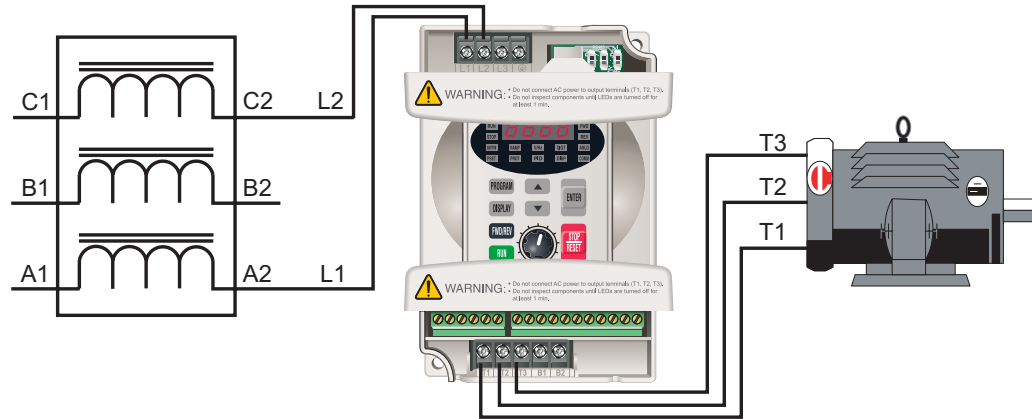

**WARNING:** Please ensure that you properly insulate terminals B1 and B2 before making any connections to single-phase power.

## Braking Resistors

Braking resistors are used to increase the control torque of the AC Drive, for frequently repeated ON-OFF cycles of the AC Drive, or for decelerating a load with large inertia.



*The use of braking resistors with GS2 Series AC drives requires no parameter setup. The AC drive automatically senses the presence of braking resistors.*

| Braking Resistor Specifications |                   |                              |                |      |       |            |
|---------------------------------|-------------------|------------------------------|----------------|------|-------|------------|
| Part Number                     | Quantity & Wiring | Drive Model                  | Braking Torque | Ohms | Watts | Duty Cycle |
| GS-20P5-BR                      | 1                 | GS2-10P2, GS2-10P5, GS2-20P5 | 270%           | 200Ω | 80    | 10%        |
| GS-21P0-BR                      | 1                 | GS2-11P0, GS2-21P0           | 125%           | 200Ω | 80    | 10%        |
| GS-22P0-BR                      | 1                 | GS2-22P0                     | 125%           | 100Ω | 300   | 10%        |
| GS-23P0-BR                      | 1                 | GS2-23P0                     | 125%           | 70Ω  | 300   | 10%        |
| GS-25P0-BR                      | 1                 | GS2-25P0                     | 125%           | 40Ω  | 400   | 10%        |
| GS-27P5-BR                      | 1                 | GS2-27P5                     | 125%           | 30Ω  | 500   | 10%        |
| GS-41P0-BR                      | 1                 | GS2-41P0                     | 125%           | 750Ω | 80    | 10%        |
| GS-42P0-BR                      | 1                 | GS2-42P0, GS2-51P0, GS2-52P0 | 125%           | 400Ω | 300   | 10%        |
|                                 | 2 in parallel     | GS2-53P0, GS2-55P0, GS2-57P5 |                |      |       |            |
| GS-43P0-BR                      | 1                 | GS2-43P0                     | 125%           | 250Ω | 300   | 10%        |
| GS-45P0-BR                      | 1                 | GS2-45P0                     | 125%           | 150Ω | 400   | 10%        |
| GS-47P5-BR                      | 1                 | GS2-47P5                     | 125%           | 100Ω | 500   | 10%        |
| GS-4010-BR                      | 1                 | GS2-4010                     | 125%           | 75Ω  | 1000  | 10%        |
|                                 | 2 in series       | GS2-5010                     |                |      |       |            |

### Braking Resistor Connections

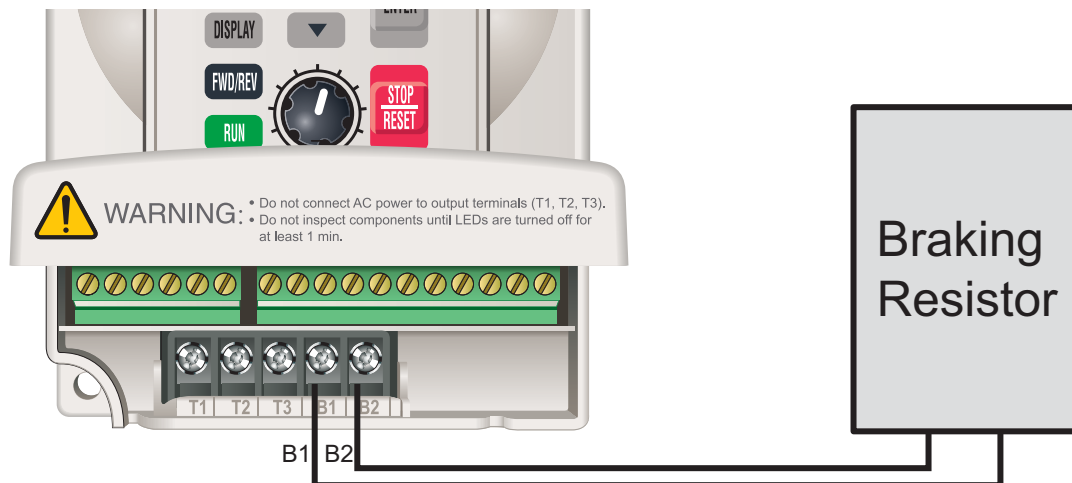

### Braking Resistor Dimensions

| Braking Resistor Dimensions (mm) |        |     |     |    |     |     |                    |
|----------------------------------|--------|-----|-----|----|-----|-----|--------------------|
| Part Number                      | Figure | L1  | L2  | H  | D   | W   | Maximum weight (g) |
| GS-20P5-BR                       | 1      | 140 | 125 | 20 | 5.3 | 60  | 160                |
| GS-21P0-BR                       | 1      | 140 | 125 | 20 | 5.3 | 60  | 160                |
| GS-22P0-BR                       | 1      | 215 | 200 | 30 | 5.3 | 60  | 750                |
| GS-23P0-BR                       | 1      | 215 | 200 | 30 | 5.3 | 60  | 750                |
| GS-25P0-BR                       | 1      | 265 | 250 | 30 | 5.3 | 60  | 930                |
| GS-27P5-BR                       | 2      | 335 | 320 | 30 | 5.3 | 60  | 1100               |
| GS-41P0-BR                       | 1      | 140 | 125 | 20 | 5.3 | 60  | 160                |
| GS-42P0-BR                       | 1      | 215 | 200 | 30 | 5.3 | 60  | 750                |
| GS-43P0-BR                       | 1      | 215 | 200 | 30 | 5.3 | 60  | 750                |
| GS-45P0-BR                       | 1      | 265 | 250 | 30 | 5.3 | 60  | 930                |
| GS-47P5-BR                       | 2      | 335 | 320 | 30 | 5.3 | 60  | 1100               |
| GS-4010-BR                       | 2      | 400 | 385 | 50 | 5.3 | 100 | 2800               |

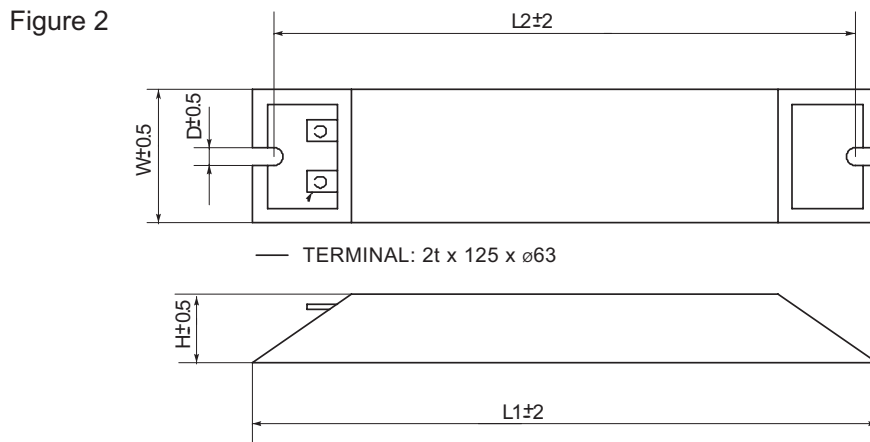
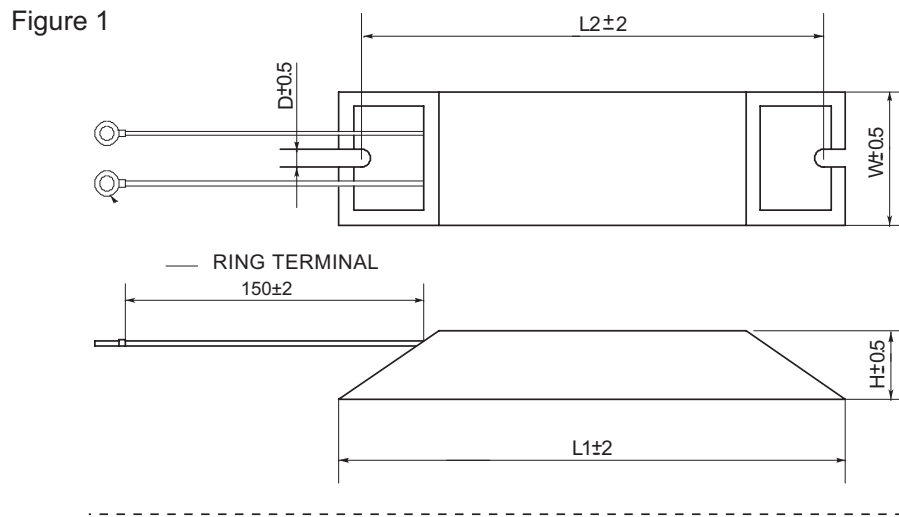

## EMI Input Filters

The EC Declaration of Conformity for the GS2 Series AC Drives was completed in conjunction with EMI Filters listed below.



*CE compliance requires the use of EMI filters; not available for 575V drives.*

| EMI Input Filter Specifications  |  |                     |                   |
|--|--|---------------------|-------------------|
| EMI Filter   | AC Drive Model / Input Phase   | Filter Input Rating | Filter Dimensions |
| <b>20DRT1W3S</b>   | GS2-10P2 / 1ph<br>GS2-10P5 / 1ph<br>GS2-11P0 / 1ph<br>GS2-20P5 / 1ph<br>GS2-21P0 / 1ph<br>GS2-22P0 / 1ph | 250V, 1-phase, 20A  | Figure 1          |
| <b>32DRT1W3C</b>   | GS2-23P0 / 1ph   | 250V, 1-phase, 32A  | Figure 2          |
| <b>not available</b>   | GS2-20P5 / 3ph   | n/a                 |                   |
| <b>10TDT1W4C *</b>   | GS2-21P0 / 3ph<br>GS2-22P0 / 3ph   | 250V, 3-phase, 10A  | Figure 3          |
| <b>26TDT1W4C *</b>   | GS2-23P0 / 3ph   | 250V, 3-phase, 26A  | Figure 4          |
| <b>40TDS4W4B</b>   | GS2-25P0 / 3ph<br>GS2-27P5 / 3ph   | 250V, 3-phase, 40A  | Figure 5          |
| <b>11TDT1W4S</b>   | GS2-41P0 / 3ph<br>GS2-42P0 / 3ph<br>GS2-43P0 / 3ph   | 480V, 3-phase, 11A  | Figure 6          |
| <b>17TDT1W44</b>   | GS2-45P0 / 3ph<br>GS2-47P5 / 3ph   | 480V, 3-phase, 17A  | Figure 7          |
| <b>26TDT1W4B4</b>  | GS2-4010 / 3ph   | 480V, 3-phase, 26A  | Figure 8          |
| <b>not available</b>   | GS2-5xxx   | n/a                 |                   |
| <b>* EMI filters 10TDT1W4C and 26TDT1W4C do not mount underneath GS2 drives.</b> |  |                     |                   |

### EMI Filter Dimensions

These filters, except 10TDT1W4C and 26TDT1W4C, mount between the drive and the sub-panel. The filters have threaded holes on their front surface for this purpose, and the drives mount directly to the front of the filters.

Figure 1 [units = mm]

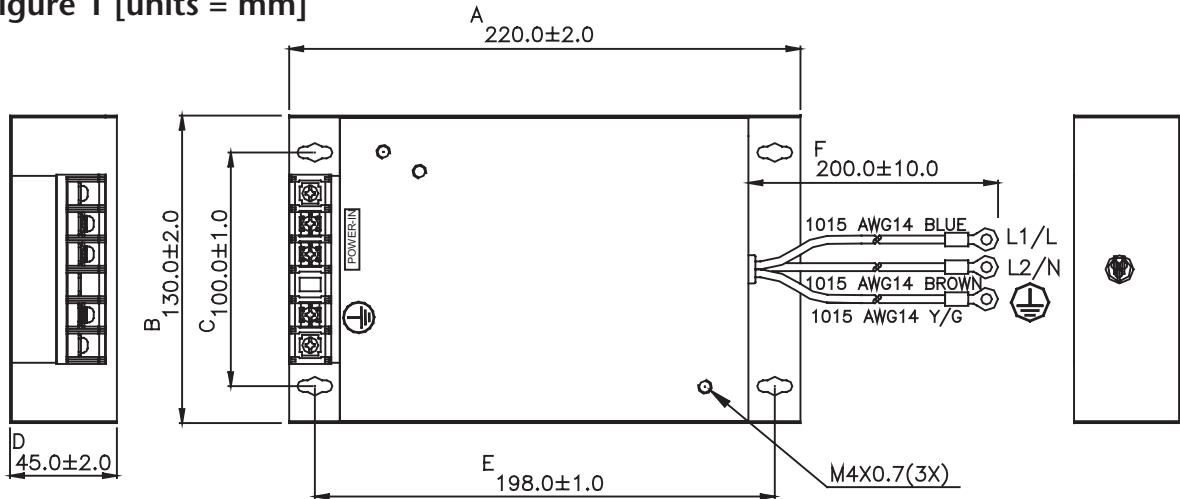

20DRT1W3S



Figure 2 [units = mm]

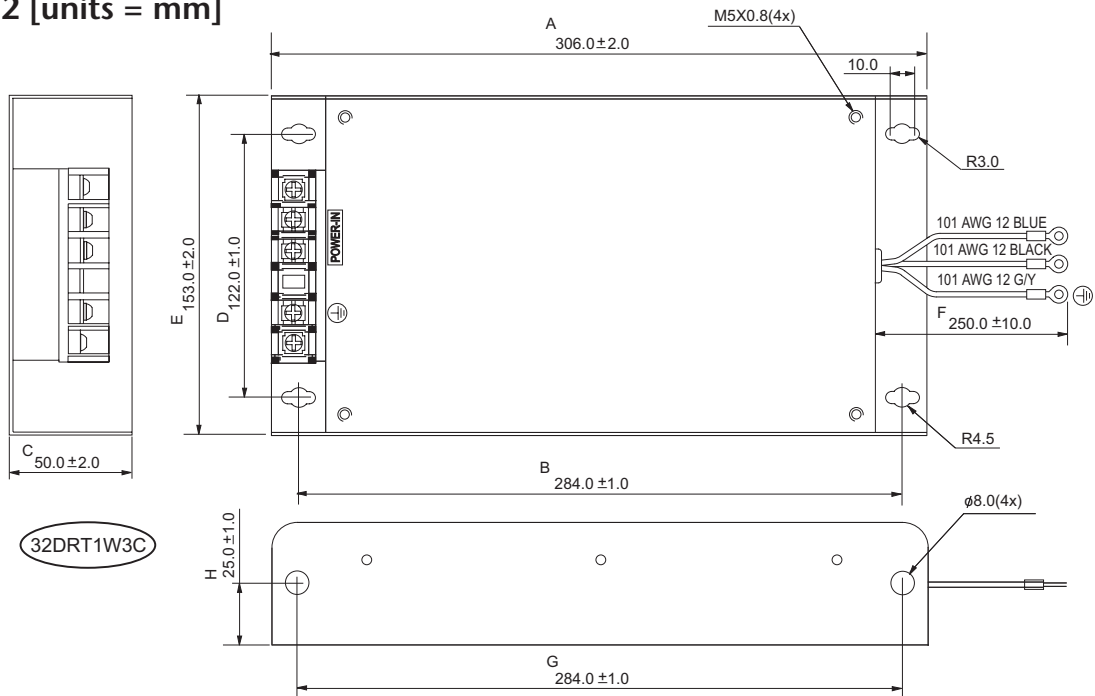

32DRT1W3C

## EMI Filter Dimensions (continued)

Figure 3 [units = mm (in)]

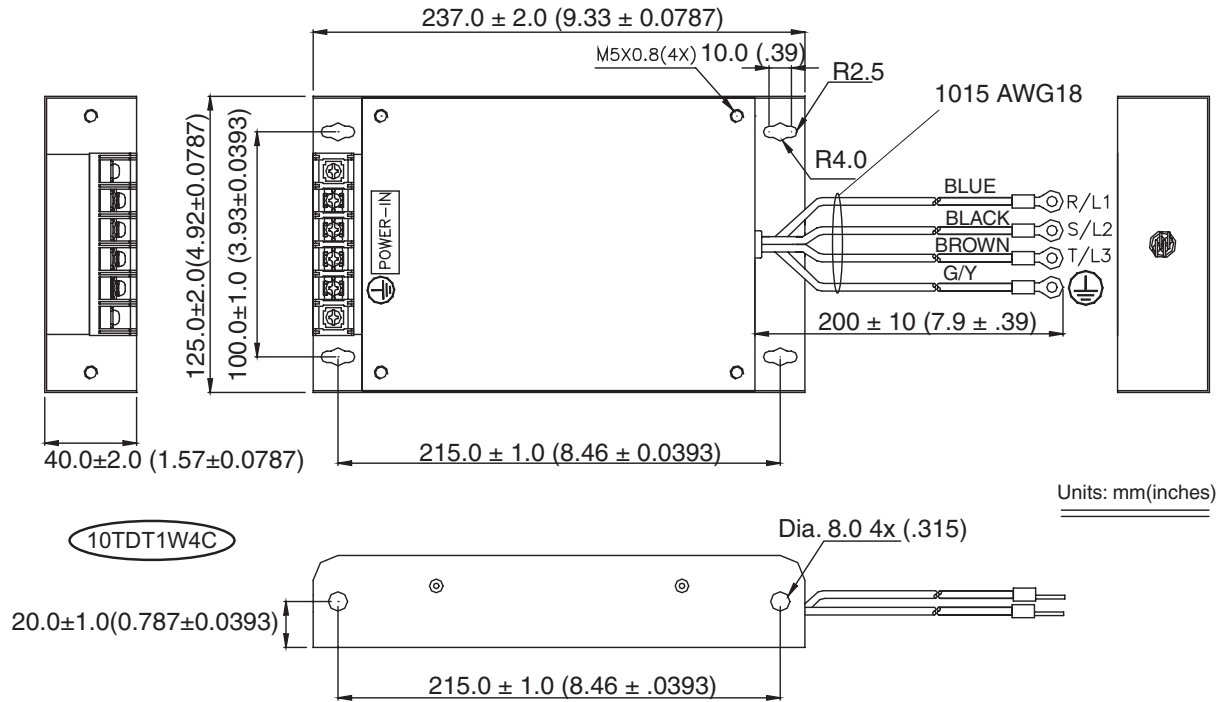

Units: mm(inches)

Figure 4 [units = mm (in)]

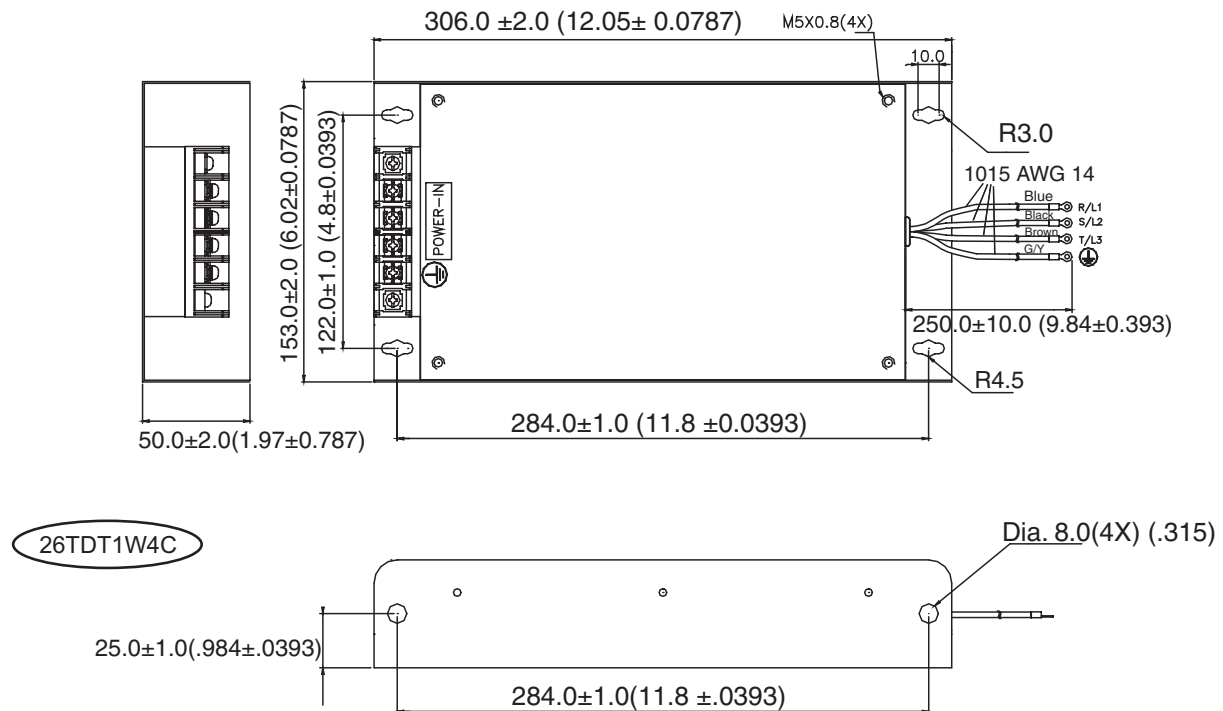

### EMI Filter Dimensions (continued)

Figure 5 [units = mm]

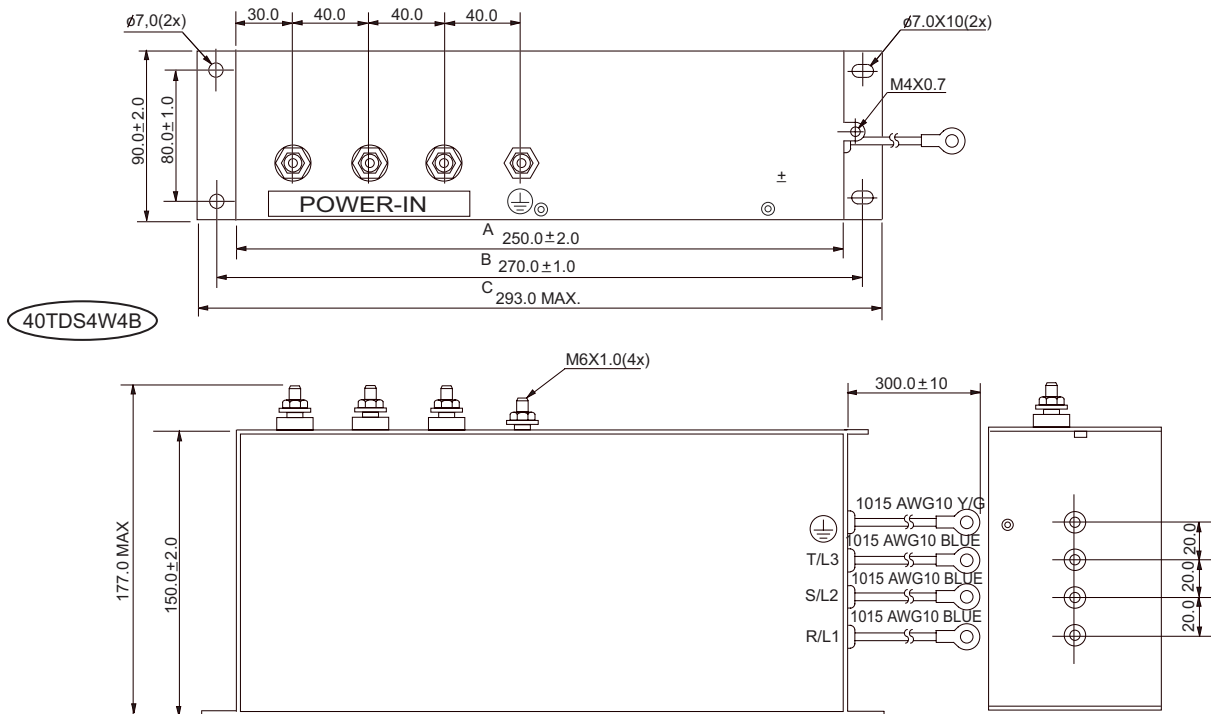
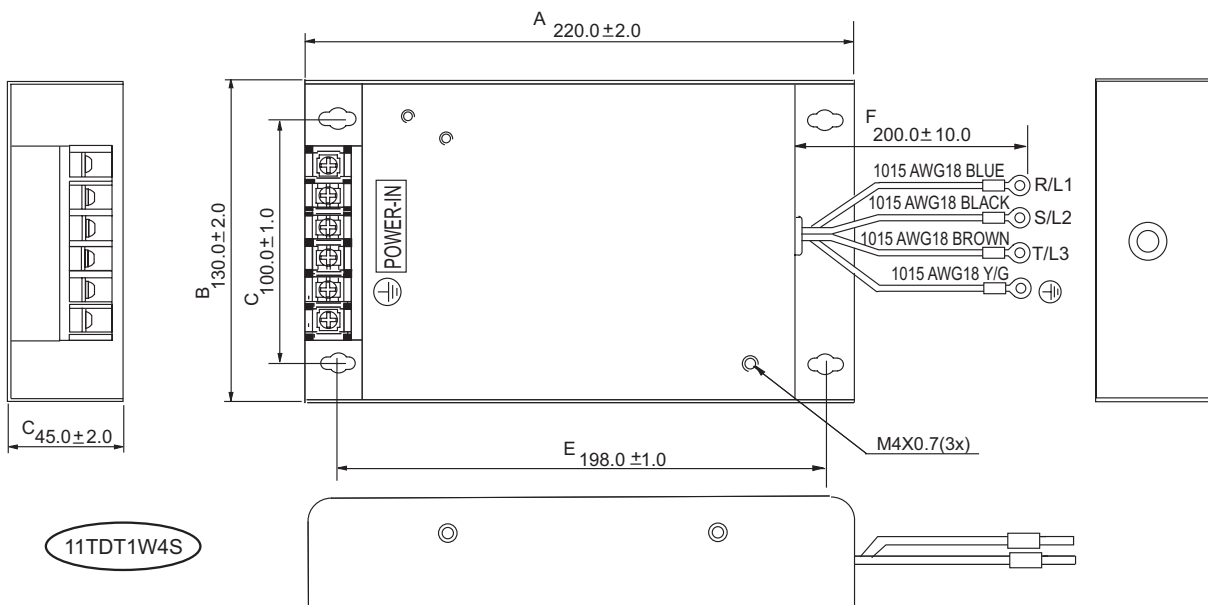

Figure 6 [units = mm]



EMI Filter Dimensions (continued)

Figure 7 [units = mm]

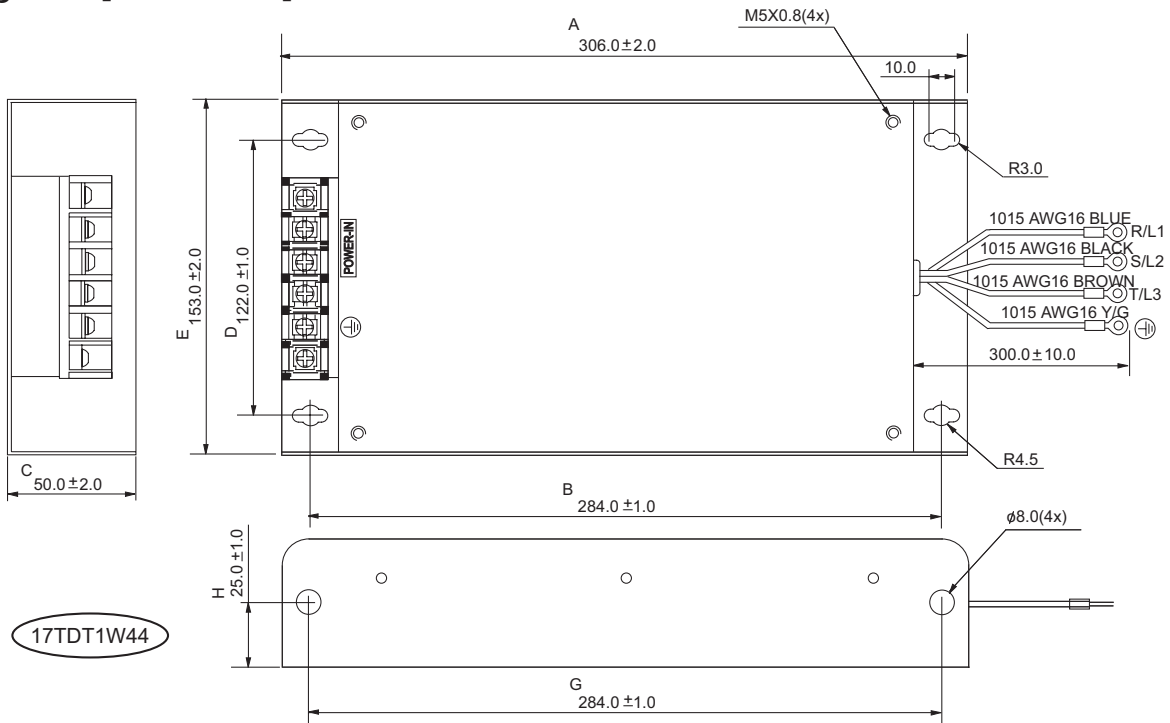
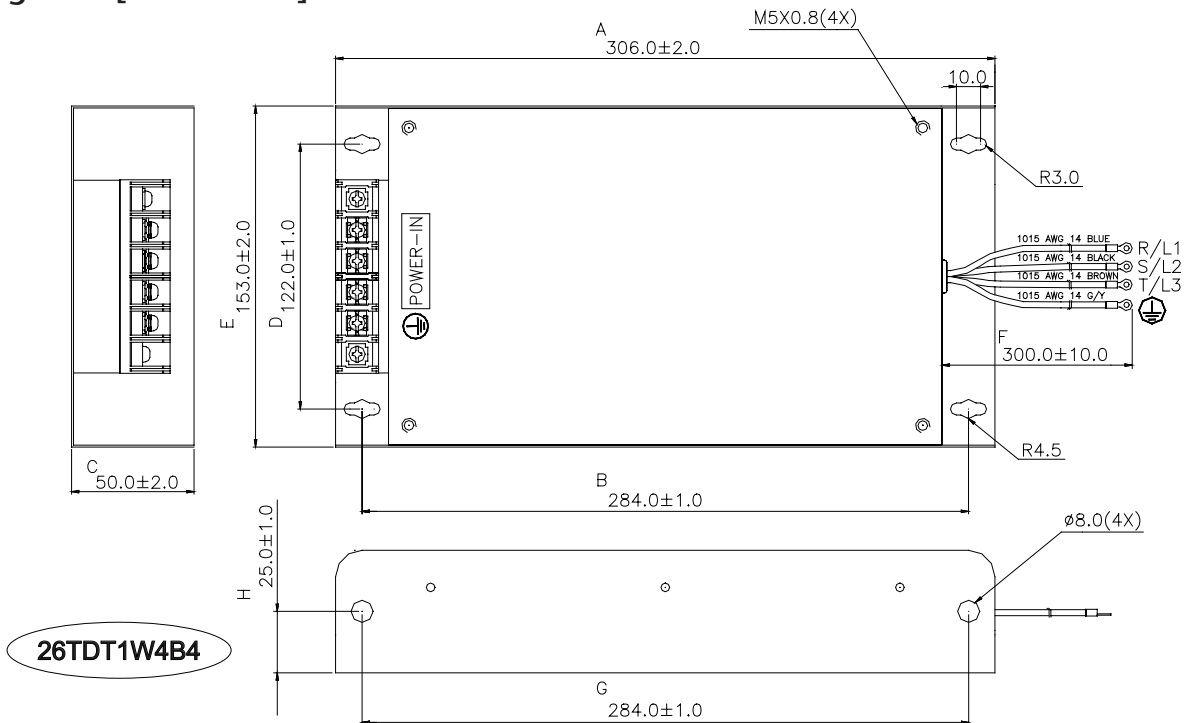

Figure 8 [units = mm]





### EMI Filter Connections

#### 1-phase Input Power

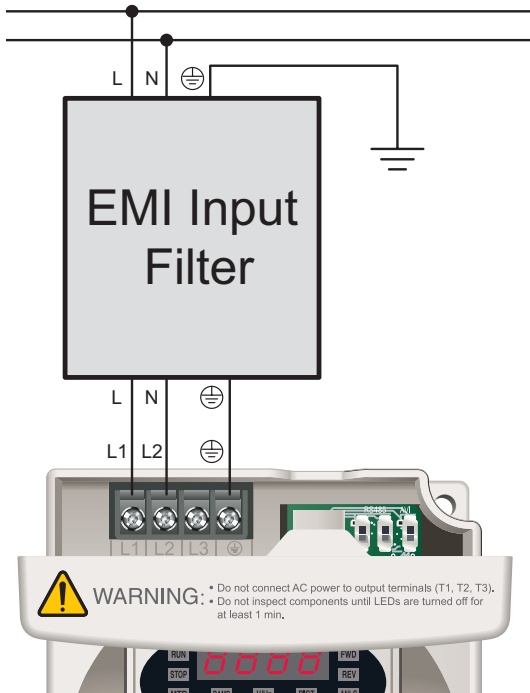

#### 3-phase Input Power

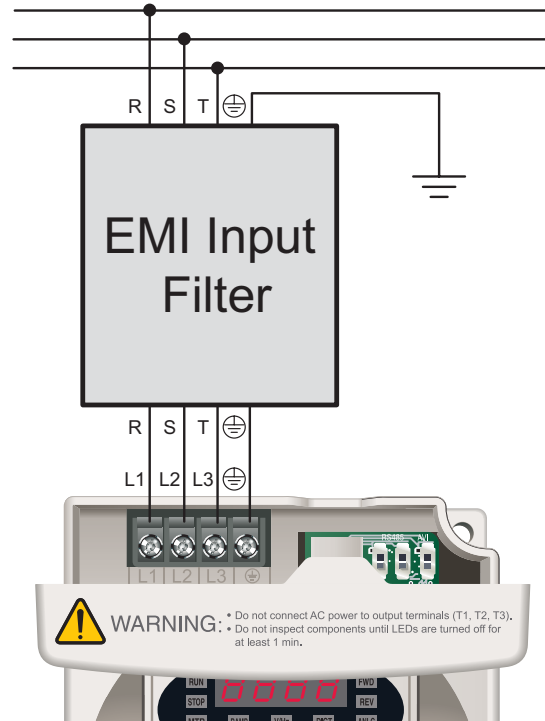

## RF Filters

### Description

Zero phase reactors, (aka RF noise filters) help reduce radiated noise from the AC drive power wiring. These RF filters are effective for noise reduction on both the input and output sides of AC drives. Attenuation quality is good in a wide range from AM band to 10 MHz.

### Wiring Method

Wind each wire four times around the core, as shown in Figure 1. The reactor should be mounted as closely as possible to the drive.

If you are unable to wire as described above due to wire size or another aspects of your application, put all wires through four reactor cores in series without winding, as shown in Figure 2.

### RF220X00A

RF Filter number RF220X00A can be used with all models of GS2 AC drives.

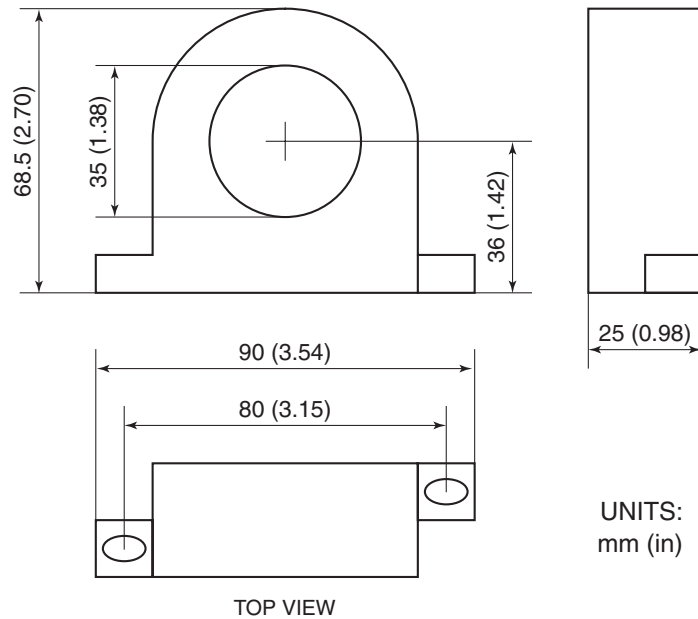

Figure 1

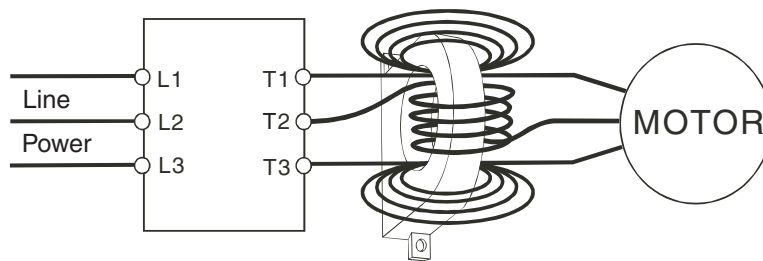
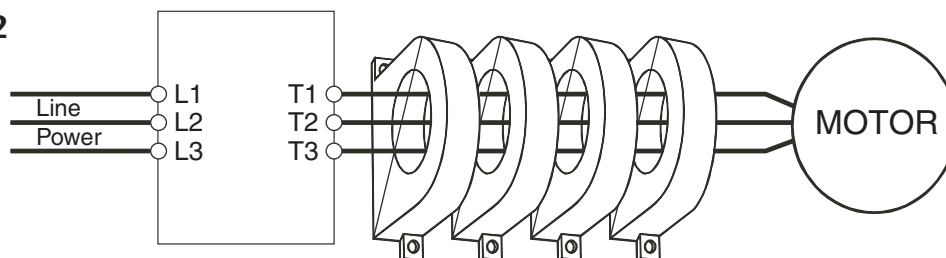

Figure 2



## Fuses and Fuse Kits

Short-circuit and ground fault protection devices are essential to prevent costly damage to your AC Drive application equipment. Fuse kits are available from AutomationDirect for the 115V through 460V GS2 Series AC Drives.



**Warning: The fuse kits provide protection only for the semiconductor components inside the AC drive. Motor branch circuit overcurrent protection should be separately provided using applicable local codes.**

The following fuse kits consist of one fuse block and fuses sized to match each GS2 Series AC Drive. Replacement fuses are also available, and their part numbers are listed in the table below.

| Fuse Kit Specifications (for 115V, 230V, 460V GS2 drive models) |                     |              |             |              |              |             |                   |          |                 |              |                 |
|---|---------------------|--------------|-------------|--------------|--------------|-------------|-------------------|----------|-----------------|--------------|-----------------|
| Part Number   | Drive Model / Phase | Fuse Block   | Wire Size   | Fuse Type    | Dimen -sions | Fuse Rating | Replacement Fuses |          |                 |              |                 |
| GS-10P2-FKIT-1P   | GS2-10P2 / 1        | 2 pole       | Al/Cu #2-14 | A3T          | Figure 1     | 300V@20A    | GS-10P2-FUSE-1P   |          |                 |              |                 |
| GS-10P5-FKIT-1P   | GS2-10P5 / 1        |              |             |              |              |             | GS-10P5-FUSE-1P   |          |                 |              |                 |
| GS-11P0-FKIT-1P   | GS2-11P0 / 1        |              |             |              |              |             | GS-11P0-FUSE-1P   |          |                 |              |                 |
| GS-20P5-FKIT-1P   | GS2-20P5 / 1        |              |             |              |              |             | GS-20P5-FUSE-1P   |          |                 |              |                 |
| GS-20P5-FKIT-3P   | GS2-20P5 / 3        | 3 pole       |             |              | Al/Cu #2-14  | A3T         | Figure 2          | 300V@10A | GS-20P5-FUSE-3P |              |                 |
| GS-21P0-FKIT-1P   | GS2-21P0 / 1        | 2 pole       |             |              |              |             | Figure 1          | 300V@30A | GS-21P0-FUSE-1P |              |                 |
| GS-21P0-FKIT-3P   | GS2-21P0 / 3        | 3 pole       |             |              |              |             | Figure 2          | 300V@20A | GS-21P0-FUSE-3P |              |                 |
| GS-22P0-FKIT-1P   | GS2-22P0 / 1        | 2 pole       |             |              |              |             | Figure 1          | 300V@45A | GS-22P0-FUSE-1P |              |                 |
| GS-22P0-FKIT-3P   | GS2-22P0 / 3        | 3 pole       |             |              |              |             | Figure 2          | 300V@25A | GS-22P0-FUSE-3P |              |                 |
| GS-23P0-FKIT-1P   | GS2-23P0 / 1        | 2 pole       |             |              |              |             | Al/Cu 2/0-#6      | A6T      | Figure 1        | 300V@60A     | GS-23P0-FUSE-1P |
| GS-23P0-FKIT-3P   | GS2-23P0 / 3        | 3 pole       |             |              |              |             |                   |          | Figure 2        | 300V@40A     | GS-23P0-FUSE-3P |
| GS-25P0-FKIT  | GS2-25P0 / 3        |              |             |              |              |             |                   |          | 300V@60A        | GS-25P0-FUSE |                 |
| GS-27P5-FKIT  | GS2-27P5 / 3        | 3 pole       |             |              |              |             |                   |          | Figure 3        | 300V @100A   | GS-27P5-FUSE    |
| GS-41P0-FKIT  | GS2-41P0 / 3        |              |             |              |              |             |                   |          | Al/Cu #2-14     | Figure 4     | 600V@10A        |
| GS-42P0-FKIT  | GS2-42P0 / 3        |              | 600V@15A    | GS-42P0-FUSE |              |             |                   |          |                 |              |                 |
| GS-43P0-FKIT  | GS2-43P0 / 3        |              | 600V@20A    | GS-43P0-FUSE |              |             |                   |          |                 |              |                 |
| GS-45P0-FKIT  | GS2-45P0 / 3        |              | 600V@30A    | GS-45P0-FUSE |              |             |                   |          |                 |              |                 |
| GS-47P5-FKIT  | GS2-47P5 / 3        |              | Figure 5    | 600V@50A     |              |             |                   |          | GS-47P5-FUSE    |              |                 |
| GS-4010-FKIT  | GS2-4010 / 3        | Al/Cu 2/0-#6 | Figure 6    | 600V@70A     | GS-4010-FUSE |             |                   |          |                 |              |                 |

### Fuses and Fuse Kits (continued)

Edison Class CC fuses and fuse blocks are available for the 575V GS2 drives.

| Fuses (for 575V GS2 drive models) |             |                       |             |   |            |       |                                     |
|-----------------------------------|-------------|-----------------------|-------------|---|------------|-------|-------------------------------------|
| Drive Model                       | Fuse Rating | Fuse Type (Qty Req'd) | Edison Fuse | Edison Fuse Block                         | Dimensions | Poles | Wire Range                          |
| GS2-51P0                          | 6A @ 600V   | CC (3)                | HCLR6       | BC6033PQ<br>or<br>CHCC3D<br>or<br>CHCC3DI | Figure 7   | 3     | 18-8 AWG<br>(1-16 mm <sup>2</sup> ) |
| GS2-52P0                          | 10A @ 600V  |                       | HCLR10      |   |            |       |                                     |
| GS2-53P0                          | 15A @ 600V  |                       | HCLR15      |   | Figure 8   |       |                                     |
| GS2-55P0                          |             |                       |             |   |            |       |                                     |
| GS2-57P5                          | 20A @ 600V  |                       | HCLR20      |   | Figure 8   |       |                                     |
| GS2-5010                          | 30A @ 600V  |                       | HCLR30      |   |            |       |                                     |

### Fuses and Fuse Kits Dimensions

Figure 1  
[units = inches]

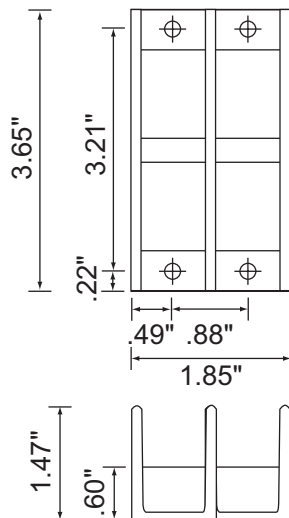

Figure 2  
[units = inches]

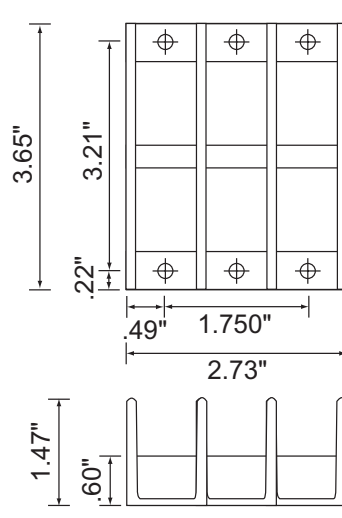
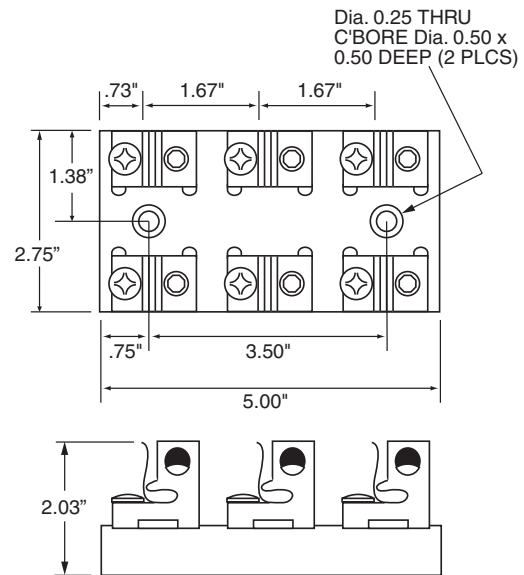

Figure 3  
[units = inches]



Fuses and Fuse Kits Dimensions (continued)

Figure 4 [units = inches]

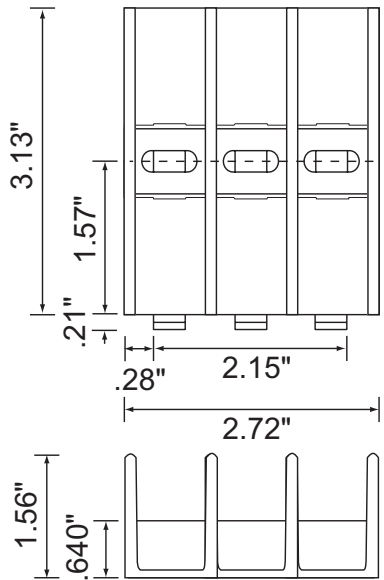

Figure 5 [units = inches]

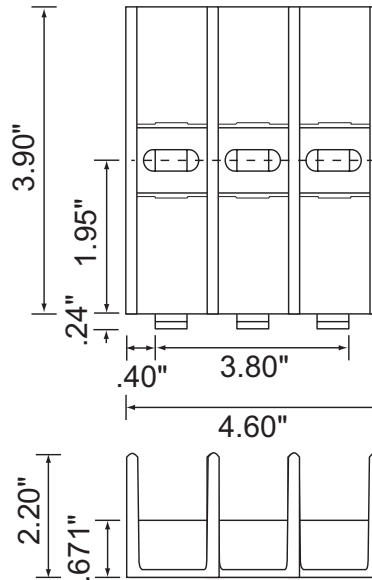

Figure 6 [units = inches]

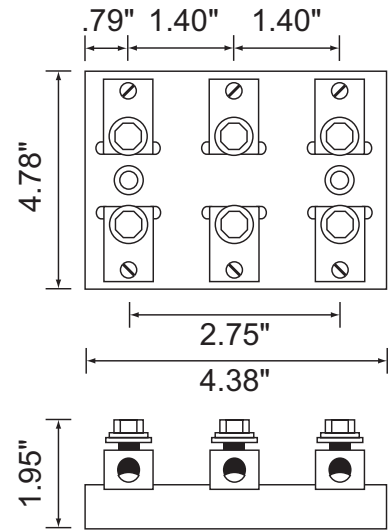

Figure 7 [units = inches (mm)]

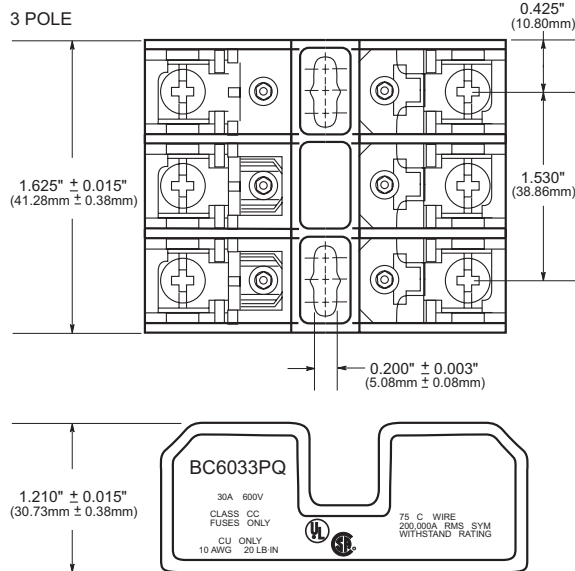
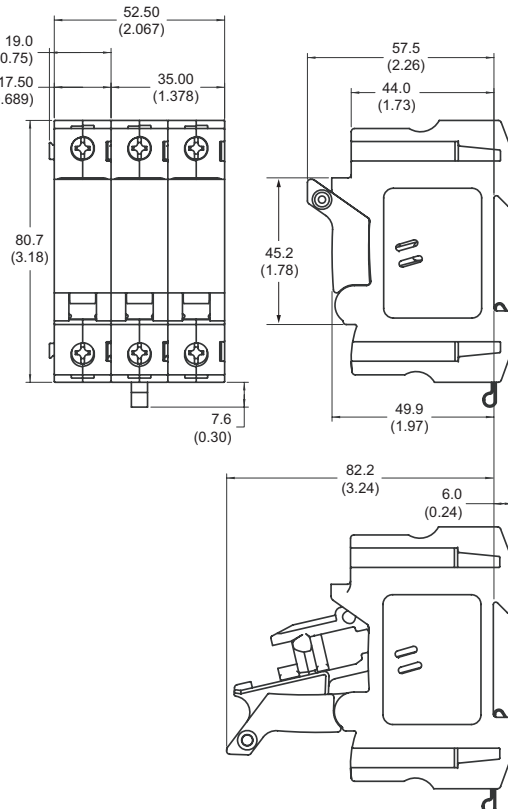

Figure 8 [units = mm (inches)]



## GS-EDRV Ethernet Interface

The GS-EDRV Ethernet Interface provides a low-cost, high-performance Ethernet link between a PLC/PC-based Control system and any GS Series AC Drive. The GS-EDRV mounts on DIN rail and communicates through cable connections to the AC drive and Ethernet hub or PC.

Functions and features of the interface:

- process input signals from the AC drive
- formats signals to conform to the Ethernet standard for connectivity to many control system architectures: H2-ERM or H4-ERM, KEPDirect EBC I/O server, or independent controller with a Modbus TCP/IP driver
- transmit the signals to the PC-based controller
- receive and translate output signals from the PLC/PC-based Control software
- distribute the output signals to the appropriate drive
- built-in web browser allows users to configure and control the drive from any web browser via the IP address of the GS-EDRV card.

The control function is not performed by the interface. The control function is performed by PC-based Control software (which is purchased separately) running on a PC.



*The GS-EDRV requires an external 24 VDC power supply.*



*The GS series drives have a provision for shutting down control or power to the drive in the event of a communications time-out. This function can be set up through the drive parameter group 9.*

### GS-EDRV

Ethernet interface number GS-EDRV can be used with all models of GS2 AC drives.

| Specifications                             |               |               |
|--|---------------|---------------|
| Part Number                                | Input Voltage | Input Current |
| GS-EDRV                                    | 10-33 VDC     | 90-135 mA     |
| <i>Can be used with all GS2 AC drives.</i> |               |               |

### GS-EDRV Ethernet Interface (continued)

GS-EDRV

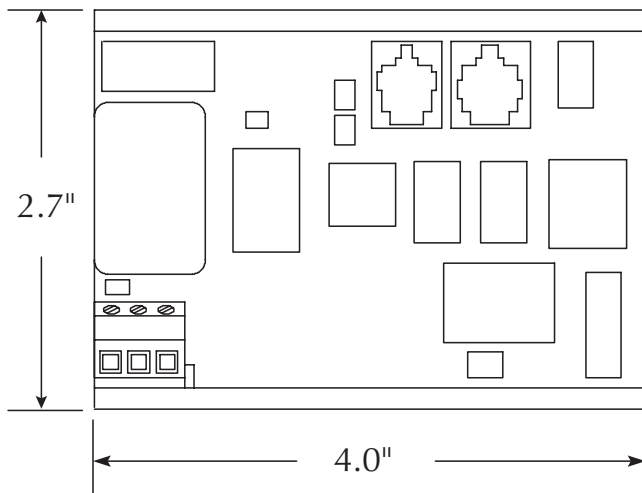

Dimensions

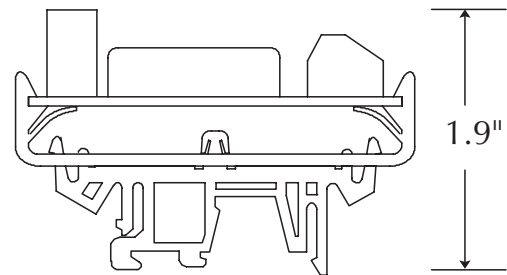

units: inches

## GS Drive Configuration Software

GSoft is the optional configuration software for the GS family of AC drives. It allows you to connect a PC to a GS series AC drive via RS-232 or RS-485, and performs a variety of functions:

| GS Series AC Drive Software |                                  |
|-----------------------------|----------------------------------|
| Part Number                 | Description                      |
| GSOFT                       | GS drives configuration software |

- Upload/download drive configurations
- Create new drive configurations using Quick Start, Detailed, or Schematic Views
- Edit drive configurations
- Archive/store multiple drive configurations on your PC
- Trend drive operation parameters
- Tune the drive PID loop
- View drive faults
- Print a schematic representation of the drive configuration

### System Requirements

GSoft will run on PCs that meet the following requirements:

- Windows 95, 98, Me, NT, 2000, and XP
- Internet Explorer 4.0 or higher (for HTML help support)
- 24Mb of available memory
- 8 Mb hard drive space
- Available RS-232 serial port



*Note: GSoft requires use of a configuration cable, GS-232CBL, which is sold separately.  
Note: RS-485 communication from an RS-232 PC port requires an FA-ISOCOCON or compatible converter, which is sold separately.*

### Software Configuration Methods

GSoft offers 3 methods of creating a new configuration for your AC drive.

#### Quick Start Configuration

The Quick Start Configuration method guides you through the most commonly used AC drive parameters. Quick Start Configuration may ONLY be used to create a new configuration. Once created and saved, a configuration built with the Quick Start Configuration method may be edited using the Detailed or Schematic View methods.

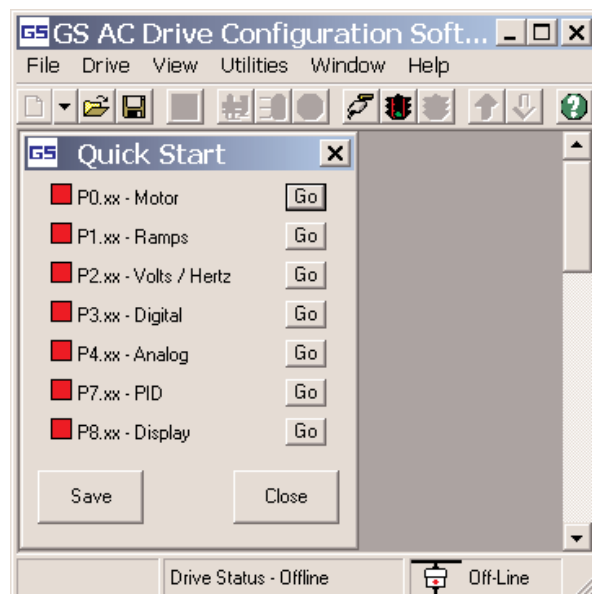



## Software Configuration Methods (continued)

### Detailed Configuration

The Detailed Configuration method provides AC drive parameter access in a tabbed dialog format. Detailed Configuration can be used for new or existing configurations.

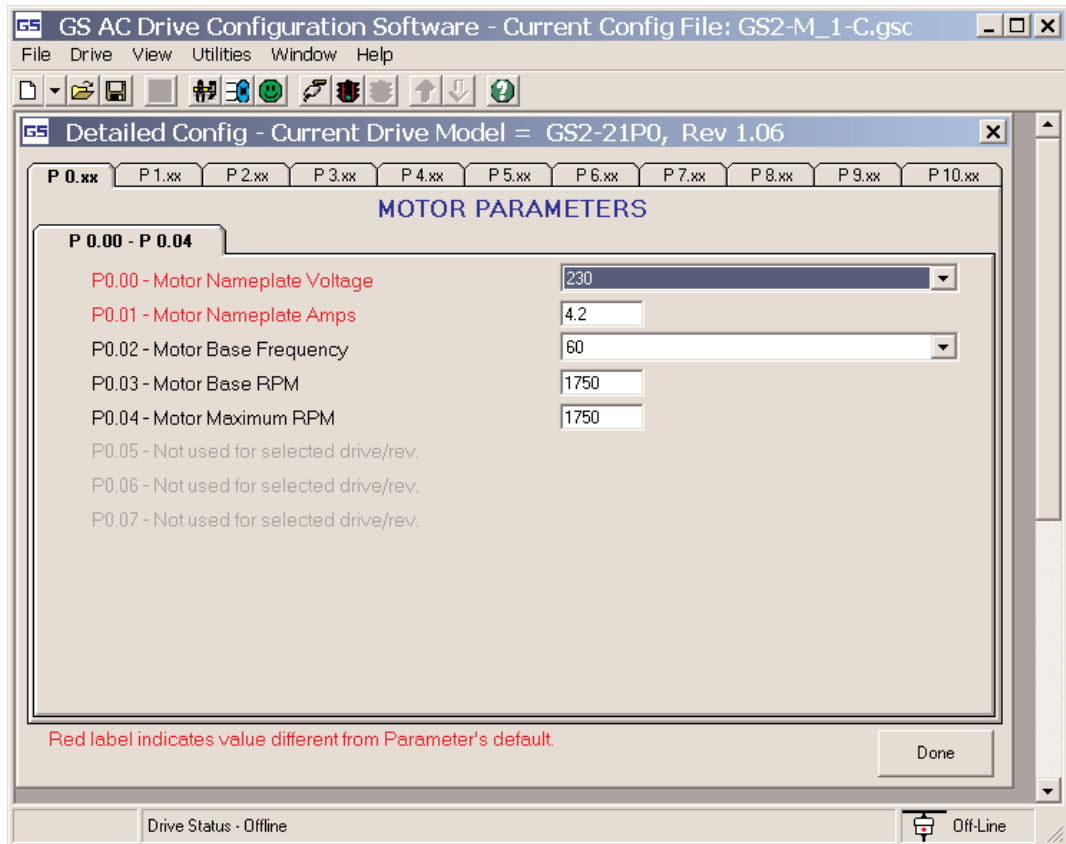

## Software Configuration Methods (continued)

### Schematic View Configuration

The Schematic View Configuration method uses a schematic picture of the AC drive and external connections to guide you through the setup of the AC drive. The Schematic View method can be used for new or existing configurations.

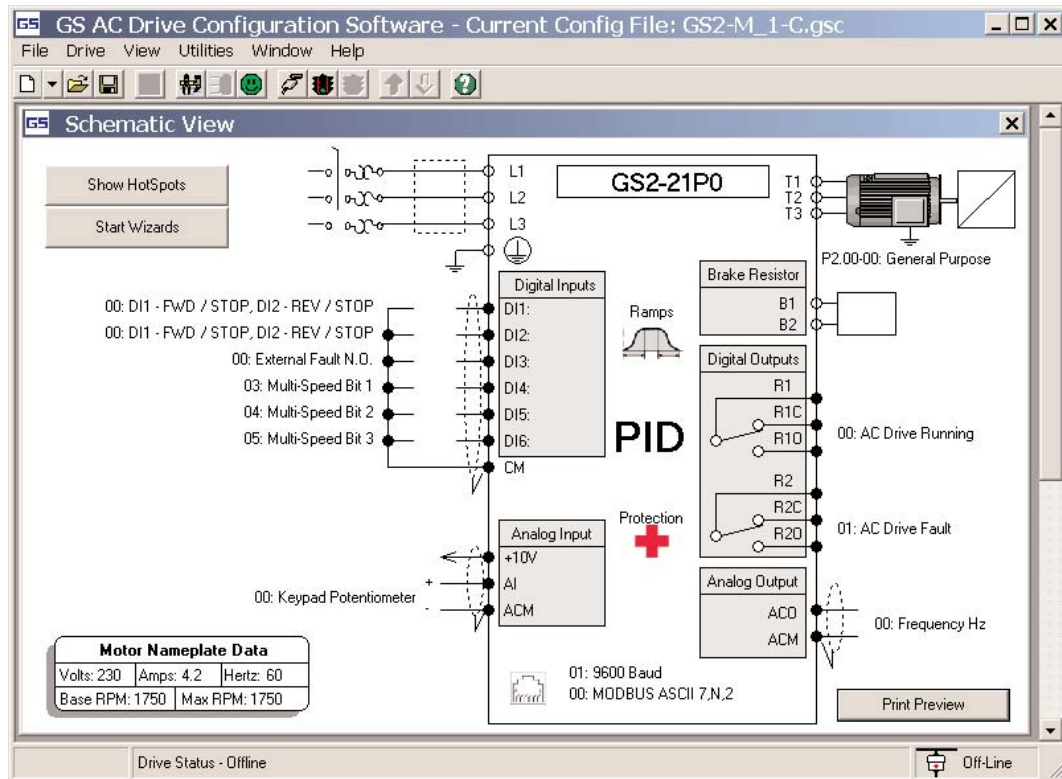

## Miscellaneous Accessories

### Configuration Cable

**GS-232CBL**

Required programming cable for GSOFT software.

### Spare Keypad

**GS2-KPD**

Spare or replacement keypad for GS2 AC drives.

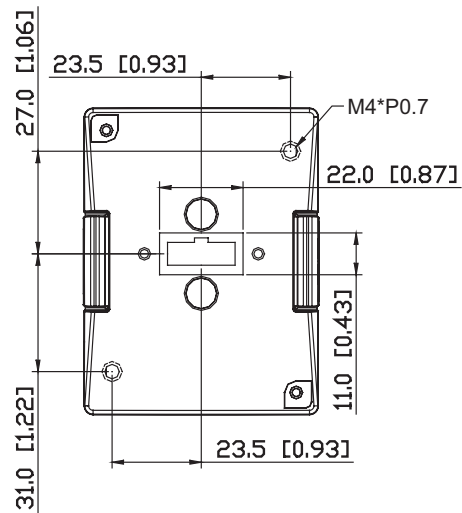
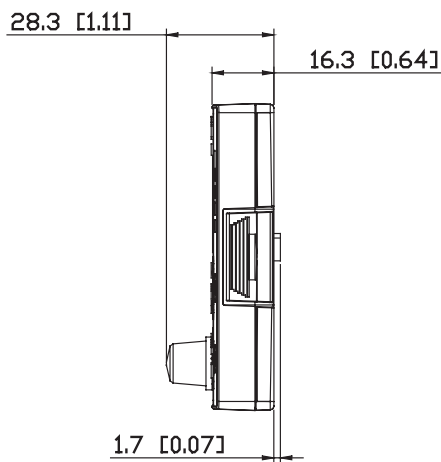
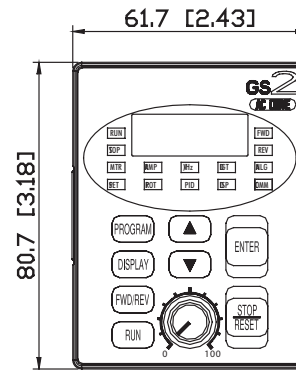

### Keypad Cables

(installation screws included)

**GS-CBL2-1L**

1 meter keypad cable

**GS-CBL2-3L**

3 meter keypad cable

**GS-CBL2-5L**

5 meter keypad cable



## Communication Distribution Blocks

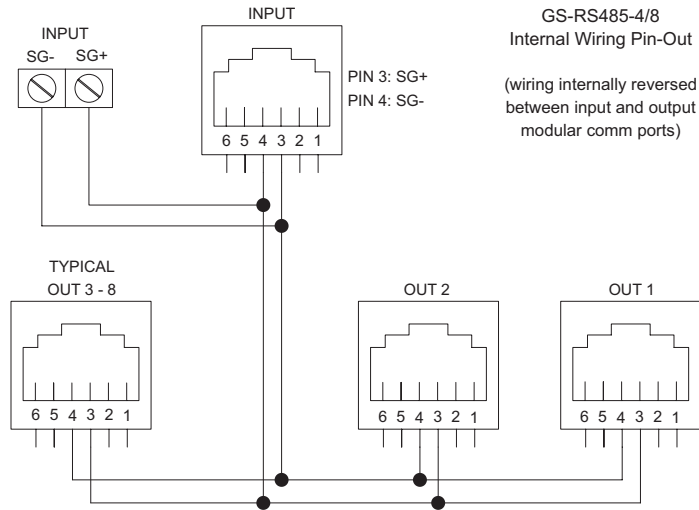

### GS-RS485-4

4 port RS485 Communication Distribution Board

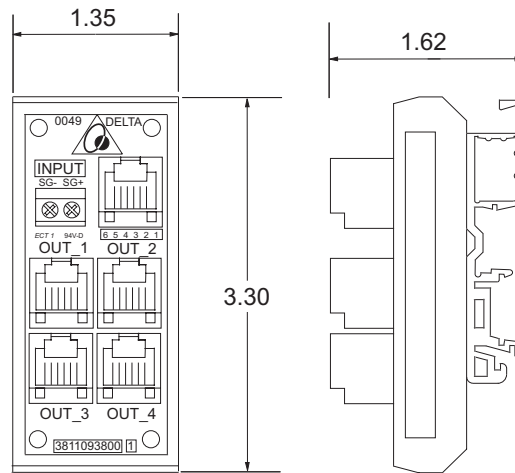
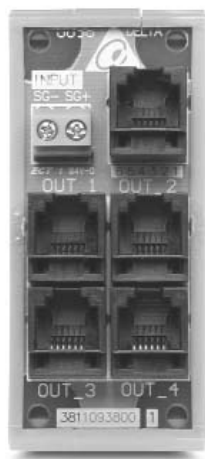

### GS-RS485-8

8 port RS485 Communication Distribution Board

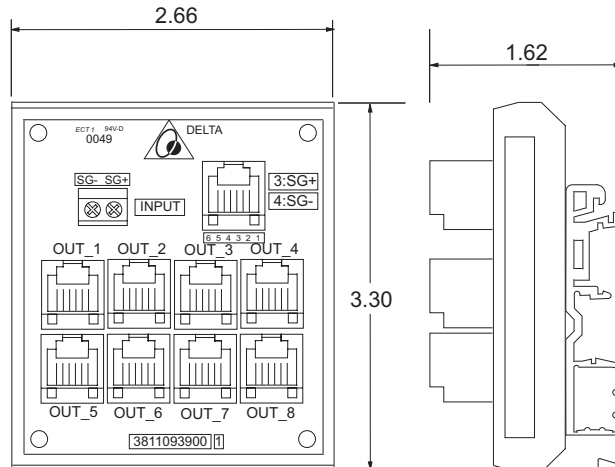

**USING GS2  
AC DRIVES WITH  
DIRECTLOGIC PLCs**

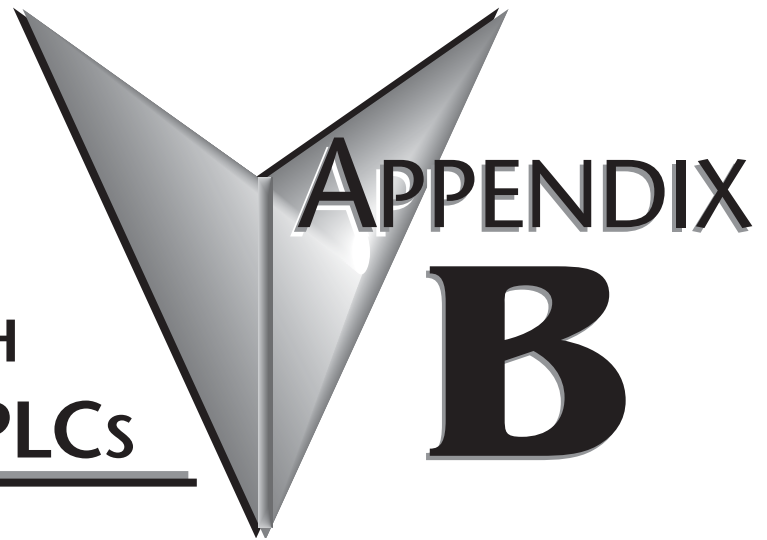

**In This Appendix**

|  |     |
|--|-----|
| Compatible <i>Direct</i> LOGIC PLCs and Modules . . . . .                | B-2 |
| Typical Connections to the GS2 Series AC Drive . . .                     | B-7 |
| DC Output Modules . . . . .  | B-7 |
| Isolated Analog Output Modules . . . . .                                 | B-8 |
| Non-Isolated Voltage or Sourcing Current Analog Output Modules . . . . . | B-9 |

## Compatible *DirectLOGIC* PLCs and Modules

The following tables show which *DirectLOGIC* PLCs and modules can be used with the GS2 Series AC Drive.

| DirectLOGIC PLC Modules for Use with GS2 AC Drives |  |
|--|--|
| <b>DL05 PLCs</b>                                   |  |
| <b>D0-05AR</b>                                     | DL05 CPU, 8 AC in / 6 Relay out, 110/220VAC Power Supply. Inputs: 8 AC inputs, 90-120 VAC, 2 isolated commons. Outputs: 6 Relay outputs, 6-27 VDC, 6-240 VAC, 2A/pt. max., 2 isolated commons  |
| <b>D0-05DR</b>                                     | DL05 CPU, 8 DC in / 6 Relay out, 110/220VAC Power Supply. Inputs: 8 DC inputs, 12-24 VDC current sinking/sourcing, 2 isolated commons. Outputs: 6 Relay outputs, 6-27 VDC, 6-240 VAC, 2A/pt. max., 2 isolated commons  |
| <b>D0-05DD</b>                                     | DL05 CPU, 8 DC in / 6 DC out, 110/220VAC Power Supply. Inputs: 8 DC inputs, 12-24 VDC current sinking/sourcing, 2 isolated commons. Outputs: 6 DC outputs, 6-27 VDC current sinking, 1.0A/pt. max.   |
| <b>D0-05DD-D</b>                                   | DL05 CPU, 8 DC in / 6 DC out, 12/24VDC Power Supply. Inputs: 8 DC inputs, 12-24 VDC current sinking/sourcing, 2 isolated commons. Outputs: 6 DC outputs, 6-27 VDC current sinking, 1.0A/pt. max.   |
| <b>D0-05DR-D</b>                                   | DL05 CPU, 8 DC in / 6 Relay out, 12/24VDC Power Supply. Inputs: 8 DC inputs, 12-24 VDC current sinking/sourcing, 2 isolated commons. Outputs: 6 Relay outputs, 6-27 VDC, 6-240 VAC, 2A/pt. max., 2 isolated commons  |
| <b>DL06 PLCs</b>                                   |  |
| <b>D0-06DD1</b>                                    | DL06 CPU, 20 DC in / 16 DC out, 110/220VAC Power Supply, with 0.3A 24VDC Auxiliary Device Power Supply. Inputs: 20 DC inputs, 12-24 VDC current sinking/sourcing, 5 isolated commons (4 inputs per common). Outputs: 16 DC outputs, 12-24 VDC current sinking, 1.0A/pt. max., 4 commons non-isolated (4 points per common) |
| <b>D0-06DR</b>                                     | DL06 CPU, 20 DC in / 16 Relay out, 110/220VAC Power Supply, with 0.3A 24VDC Auxiliary Device Power Supply. Inputs: 20 DC inputs, 12-24 VDC current sinking/sourcing, 5 isolated commons (4 inputs per common). Outputs: 16 Relay outputs, 6-27 VDC, 6-240 VAC, 2A/pt. max., 4 isolated commons (4 points per common)       |
| <b>D0-06AR</b>                                     | DL06 CPU, 16 AC in / 20 Relay out, 110/220VAC power supply, with 0.3A 24VDC auxiliary device power supply. Inputs: 20 AC inputs, 90-120 VAC, 5 isolated commons (4 inputs per common). Outputs: 16 Relay outputs, 6-27 VDC, 6-240 VAC, 2A/pt. max., 4 isolated commons (4 points per common)                               |
| <b>D0-06DD1-D</b>                                  | DL06 CPU, 20 DC in / 16 DC out, 12/24VDC Power Supply. Inputs: 20 DC inputs, 12-24 VDC current sinking/sourcing, 5 isolated commons (4 inputs per common). Outputs: 16 DC outputs, 12-24 VDC current sinking, 1.0A/pt. max., 4 commons non-isolated (4 points per common).   |
| <b>D0-06DR-D</b>                                   | DL06 CPU, 20 DC in / 16 Relay out, 110/220VAC Power Supply. Inputs: 20 DC inputs, 12-24 VDC current sinking/sourcing, 5 isolated commons (4 inputs per common). Outputs: 16 Relay outputs, 6-27 VDC, 6-240 VAC, 2A/pt. max., 4 isolated commons (4 points per common)  |
| <b>DL05/DL06 DC Input/Output Module</b>            |  |
| <b>D0-08CDD1</b>                                   | 4 pt. 12-24VDC current sinking/sourcing input, 1 common, 4 pt. 12-24VDC sinking output, 0.3A/point, 1.2A/module, removable terminal, no fuse   |

| DirectLOGIC PLC Modules for Use with GS2 AC Drives (cont.) |   |
|--|---|
| <b>DL05/DL06 DC Output Module</b>                          |   |
| <b>D0-10TD1</b>  | 10 pt. 12-24 VDC current sinking output module, 2 commons non-isolated (5 pts. per common), 0.3A/point, 1.5A/common, removable terminal, no fuse  |
| <b>D0-16TD1</b>  | 16 pt. 12-24 VDC current sinking output module, 2 commons non-isolated (5 pts. per common), 0.3A/point, 1.5A/common, removable terminal, no fuse  |
| <b>DL05/DL06 Analog Module</b>                             |   |
| <b>F0-2AD2DA-2</b>   | 2 channel in, 2 channel out voltage analog option card; 0-5V, 0-10V   |
| <b>F0-4AD2DA-2</b>   | 4 channel in, 2 channel out voltage analog option card; 0-5V, 0-10V   |
| <b>F0-4AD2DA-1</b>   | 4 channel in, 2 channel sourcing out current analog option card; 4-20mA   |
| <b>DL105 PLCs</b>  |   |
| <b>F1-130DR</b>  | DL130 CPU, 10 DC in / 8 Relay out, 110/220VAC Power Supply. Inputs: 10 DC inputs, 12-24 VDC current sinking/sourcing, 3 isolated commons. Outputs: 8 relay outputs, 12-30 VDC, 12-250VAC, 7A/pt. max., 4 isolated commons           |
| <b>F1-130DD</b>  | DL130 CPU, 10 DC in / 8 DC out, 110/220VAC Power Supply. Inputs: 10 DC inputs, 12-24 VDC current sinking/sourcing, 3 isolated commons. Outputs: 8 DC outputs, 5-30VDC current sinking, 0.5A/pt. max, 3 internally connected commons |
| <b>F1-130DR-D</b>  | DL130 CPU, 10 DC in / 8 Relay out, 12/24VDC Power Supply. Inputs: 10 DC inputs, 12-24 VDC current sinking/sourcing, 3 isolated commons. Outputs: 8 relay outputs, 12-30 VDC, 12-250VAC, 7A/pt. max., 4 isolated commons             |
| <b>F1-130DD-D</b>  | DL130 CPU, 10 DC in / 8 DC out, 12/24VDC Power Supply. Inputs: 10 DC inputs, 12-24 VDC current sinking/sourcing, 3 isolated commons. Outputs: 8 DC outputs, 5-30VDC current sinking, 0.5A/pt. max, 3 internally connected commons   |
| <b>DL205 DC Output Module</b>                              |   |
| <b>D2-16TD1-2</b>  | 16 pt. 12-24 VDC current sinking output module, 1 common (2 common terminals), 0.1A/point, 1.6A/module, no fuse, European type removable terminal   |
| <b>D2-32TD1</b>  | 32 pt. 12-24 VDC current sinking output module. 1 common (4 common terminals), 0.1A/point, 3.2A/module, no fuse   |

| DirectLOGIC PLC Modules for Use with GS2 AC Drives (cont.) |   |
|--|---|
| <b>DL205 Relay Output Modules</b>                          |   |
| <b>D2-04TRS</b>  | 4-pt. 5-30 VDC or 5-240 VAC isolated relay output module, 4 Form A (SPST) relays, 4 commons, 4A/point, 8.0A/module, replaceable fuse, removable terminal          |
| <b>D2-08TR</b>   | 8-pt. 5-30 VDC or 5-240 VAC output module, 8 Form A (SPST) relays, 1 common (2 common terminals), 1A/point, 4.0A/module, replaceable fuse, removable terminal     |
| <b>F2-08TR</b>   | 8-pt relay output, 10A/common, 5-30VDC or 5-240VAC  |
| <b>F2-08TRS</b>  | 8-pt. 12-28 VDC or 12-240 VAC output module, 5 Form A (SPST) relays, 3 Form C (SPDT) relays, 8 isolated commons, 7A/point max., no fuses, removable terminal      |
| <b>D2-12TR</b>   | 12 pt. 5-30 VDC or 5-240 VAC relay output module, 12 Form A (SPST) relays, 2 commons, 1.5A/point max., 3.0A/common, 2 replaceable fuses, removable terminal       |
| <b>DL205 DC Input/Output Modules</b>                       |   |
| <b>D2-08CDR</b>  | 4 pt. 24VDC sinking/sourcing input, 1 common, 4 pt. relay output, 1A/pt., 4A/module, 1 common, replaceable fuse   |
| <b>DL205 Analog Output Module</b>                          |   |
| <b>F2-02DAS-1</b>  | 2 channel, 16-bit resolution, Isolated 4-20mA sourcing (2 isolated commons). Designed to operate with 24 VDC user-supplied power supply.                          |
| <b>F2-02DAS-2</b>  | 2 channel analog output, 16 bit resolution, isolated, range: 0-5V, 0-10V (2 isolated commons). Designed to operate with 24 VDC user-supplied power supply.        |
| <b>F2-08DA-1</b>   | 8 channel analog output module, 12 bit resolution, range: 4-20mA, sink or source output configurable. Designed to operate with 24 VDC user-supplied power supply. |
| <b>F2-02DA-2</b>   | 2 channel analog output module, 12 bit resolution, ranges: 0-5V, 0-10V, -5 to +5V, -10 to +10V. Designed to operate with 24 VDC user-supplied power supply.       |
| <b>F2-08DA-2</b>   | 8 channel analog output module, 12 bit resolution, ranges: 0-5V, 0-10V. Designed to operate with 24 VDC user-supplied power supply.                               |
| <b>DL205 Analog Input Modules</b>                          |   |
| <b>F2-04AD-2</b>   | 4 channel, 12-bit, 0-5V, 0-10V, -5 to +5V, -10 to +10V. Designed to operate with a 24VDC user supplied power supply.  |
| <b>F2-08AD-2</b>   | 8 channel, 12-bit, 0-5V, 0-10V, -5 to +5V, -10 to +10V. Designed to operate with a 24VDC user supplied power supply.  |
| <b>DL205 Analog Combination Modules</b>                    |   |
| <b>F2-8AD4DA-1</b>   | 8 channel, 16-bit, 0-20mA in; 4 channel, 16-bit, 4-20mA out. Designed to operate with a 24VDC user supplied power supply.   |
| <b>F2-8AD4DA-2</b>   | 8 channel, 16-bit, 0-5V, 0-10V in; 4 channel, 16-bit, 0-5V, 0-10V out. Designed to operate with a 24VDC user supplied power supply.                               |



| DirectLOGIC PLC Modules for Use with GS2 AC Drives (cont.) |   |
|--|---|
| <b>DL305 Relay Output Modules</b>                          |   |
| <b>D3-08TR</b>   | 8 pt. 5-30 VDC or 5-220 VAC output module, 5A/point DC or 4A/point AC, 8 Form A relays (SPST), 2 commons (isolated), non-removable terminal, 2 user replaceable fuses                       |
| <b>D3-16TR</b>   | 16 pt. 5-30 VDC or 5-220 VAC output module, 2A/point, 16 Form A relays (SPST), 2 commons (isolated), removable terminal, no internal fuses  |
| <b>DL305 Analog Output Modules</b>                         |   |
| <b>F3-04DAS</b>  | 4 channel isolated analog output module, 12 bit resolution, ranges: 0 to 5V, 0 to 10V, -5 to +5V, -10 to +10V, 4 to 20mA, 0 to 20mA. -750 to +750 VDC channel to channel isolation          |
| <b>F3-16AD</b>   | 16 channel analog input module, 12 bit resolution, ranges: -5 to +5V, -10 to +10V, 0 to 10V, 0 to 20mA. Each point can be either a voltage or current input                                 |
| <b>DL305 Analog Output Modules</b>                         |   |
| <b>F3-04DAS</b>  | 4 channel isolated analog output module, 12 bit resolution, ranges: 0 to 5V, 0 to 10V, -5 to +5V, -10 to +10V, 4 to 20mA, 0 to 20mA. -750 to +750 VDC channel to channel isolation          |
| <b>DL405 DC Output Modules</b>                             |   |
| <b>D4-08TD1</b>  | 8 pt. 12-24 VDC current sinking output module, 2 commons (internally connected), 2A/point, 5A/common, removable terminal  |
| <b>D4-16TD1</b>  | 16 pt. 5-24 VDC current sinking output module, 2 commons (internally connected), 0.5A/point, 3A/common, removable terminal  |
| <b>D4-32TD1</b>  | 32 pt. 5-24 VDC current sinking output module, 4 commons (isolated), 0.2A/point, 1.6A/common. Requires one connector, sold separately   |
| <b>DL405 Relay Output Modules</b>                          |   |
| <b>D4-08TR</b>   | 8 pt. 5-30 VDC or 5-250 VAC output module, 8 Form A (SPST) relays, 2 commons (isolated), 2A/point, 5A/common, removable terminal  |
| <b>F4-08TRS-1</b>  | 8 pt. 12-30 VDC or 12-250 VAC isolated output module, 4 Form A (SPST) and 4 Form C (SPDT) relays, 8 commons (isolated), 10A/point, 40A/module, removable terminal                           |
| <b>F4-08TRS-2</b>  | 8 pt. 12-30 VDC or 12-250 VAC isolated output module, 4 Form A (SPST) relays and 4 Form C (SPDT) relays, 8 commons (isolated), 5A/point, 40A/module, replaceable fuses, removable terminals |
| <b>D4-16TR</b>   | 16 pt. 5-30 VDC or 5-250 VAC output module, 8 Form A (SPST) relays, 2 commons (isolated), 1A/point, 5A/common, removable terminals  |
| <b>DL405 Analog Input Modules</b>                          |   |
| <b>F4-04ADS</b>  | 4 channel isolated analog input module, 12 bit resolution, ranges: 0 - 5V, 0 - 10V, 1 - 5V, -5V to +5V, -10V to +10V, 0 - 20mA, 4 - 20mA  |
| <b>F4-08AD</b>   | 8 channel analog input module, 12 bit resolution, ranges: 4 to 20mA, 1 to 5V, 0 to 20mA, 0 to 5V, 0 to 10V, -5V to +5V, -10V to +10V  |
| <b>F4-16AD-2</b>   | 16 channel analog input module, 12 bit resolution, ranges: 0-5V, 0-10V  |
| <b>DL405 Analog Output Modules</b>                         |   |
| <b>F4-04DAS-1</b>  | 4 channel analog output module, 16 bit resolution, isolated, range: 4 to 20mA current sourcing  |
| <b>F4-04DAS-2</b>  | 4 channel analog output module, 16 bit resolution, isolated, range: 0-5V, 0-10V   |
| <b>F4-08DA-2</b>   | 8 channel analog output module, 12 bit resolution, range: 0-5V or 0-10V   |
| <b>F4-16DA-2</b>   | 16 channel analog output module, 12 bit resolution, range: 0-5V or 0-10V  |

| DirectLOGIC PLC Modules for Use with GS2 AC Drives (cont.) |   |
|--|---|
| <b>Terminator I/O DC Output Modules</b>                    |   |
| <b>T1K-08TD1</b>   | 8 pt. 12-24 VDC current sinking output module, 4 points per common, 1.0A/point, 2 replaceable fuses (T1K-FUSE-1). (use with T1K-08B or T1K-08B-1 terminal base)   |
| <b>T1K-16TD1</b>   | 16 pt. 12-24 VDC current sinking output module, 4 points per common, 1.0A/point, 4 replaceable fuses (T1K-FUSE-1). (use with T1K-16B or T1K-16B-1 terminal base)  |
| <b>Terminator I/O Relay Output Modules</b>                 |   |
| <b>T1K-08TR</b>  | 8 pt. 5-30 VDC or 5-240 VAC output module, 8 Form A (SPST) relays, 4 points per common, 2.0A/point max., 2 replaceable fuses (T1K-FUSE-2). (use with T1K-08B or T1K-08B-1 terminal base)  |
| <b>T1K-16TR</b>  | 16 pt. 5-30 VDC or 5-240 VAC output module, 16 Form A (SPST) relays, 4 points per common, 2.0A/point max., 4 replaceable fuses (T1K-FUSE-2). (use with T1K-16B or T1K-16B-1 terminal base)  |
| <b>T1K-08TRS</b>   | 8 pt. 5-30 VDC or 5-240 VAC isolated relay output module, 8 Form A (SPST) relays, 1 point per common, 7.0A/point max., 8 replaceable fuses (T1K-FUSE-3). (isolation requires use of T1K-16B or T1K-16B-1 terminal base)   |
| <b>Terminator I/O Analog Input Modules</b>                 |   |
| <b>T1F-08AD-2</b>  | 8 channel analog input module, 14 bit resolution (13 bit plus sign bit), range: 0-5VDC, 0-10VDC, +/-5VDC, +/-10VDC (Use with T1K-08B or T1K-08B-1 terminal base.)   |
| <b>T1F-16AD-2</b>  | 16 channel analog input module, 14 bit resolution (13 bit plus sign bit), range: 0-5VDC, 0-10VDC, +/-5VDC, +/-10VDC (use with T1K-16B or T1K-16B-1 terminal base.)  |
| <b>Terminator I/O Analog Output Modules</b>                |   |
| <b>T1F-08DA-2</b>  | 8 channel analog output, 12 bit resolution, range: 0-5VDC, 0-10VDC, +/-5VDC, +/-10VDC. (use with T1K-08B or T1K-08B-1 terminal base)  |
| <b>T1F-16DA-2</b>  | 16 channel analog output, 12 bit resolution, range: 1-5VDC, 1-10VDC, +/-5VDC, +/-10VDC. (use with T1K-16B or T1K-16B-1 terminal base)   |
| <b>Terminator I/O Analog Input/Output Modules</b>          |   |
| <b>T1F-8AD4DA-1</b>  | 8 channel analog input module and 4 channel analog output module. Inputs: 14 bit resolution (13 bit plus sign bit), range: -20 to 20mA, 0-20mA, 4-20mA. Outputs: 12 bit resolution, range: 4-20mA, sinking or sourcing compatible. (use with T1K-08B or T1K-08B-1 terminal base)    |
| <b>T1F-8AD4DA-2</b>  | 8 channel analog input module and 4 channel analog output module. Inputs: 14 bit resolution (13 bit plus sign bit), range: 0-5VDC, 0-10VDC, +/-5VDC, +/-10VDC. Outputs: 12 bit resolution, range: 0-5VDC, 0-10VDC, +/-5VDC, +/-10VDC. (use with T1K-08B or T1K-08B-1 terminal base) |

# Typical Connections to the GS2 Series AC Drive

The following drawings show some typical connections between the GS2 Series AC Drive and DirectLOGIC PLCs and modules.

## DC Output Modules

- D0-05DD
- D0-05DD-D
- D0-06DD1
- D0-06DD1-D
- D0-10TD1
- D0-16TD1
- D2-16TD1-2
- D2-32TD1
- D4-08TD1
- D4-16TD1
- D4-32TD1
- T1K-08TD1
- T1K-16TD1

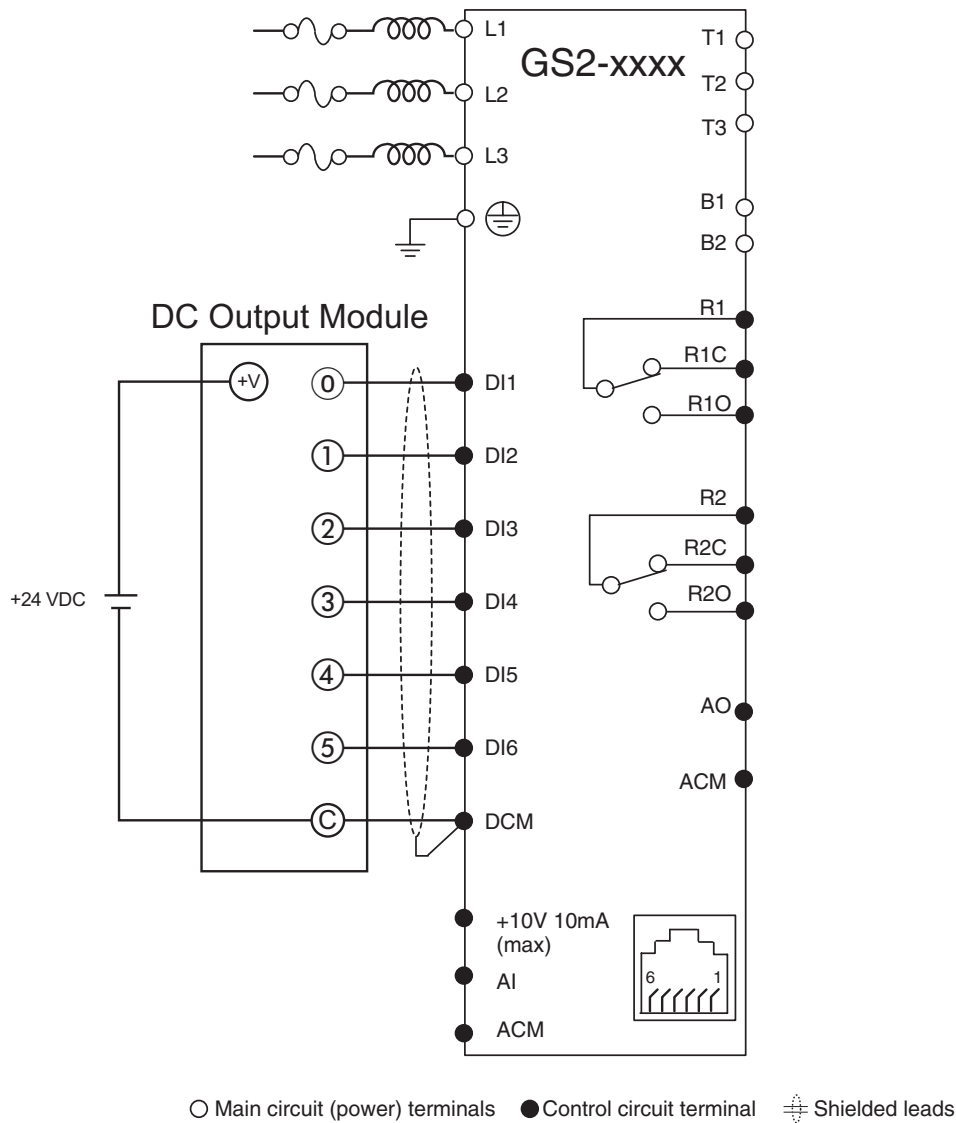

### Isolated Analog Output Modules

- F2-02DAS-1
- F2-02DAS-2
- F4-04DAS-1
- F4-04DAS-2

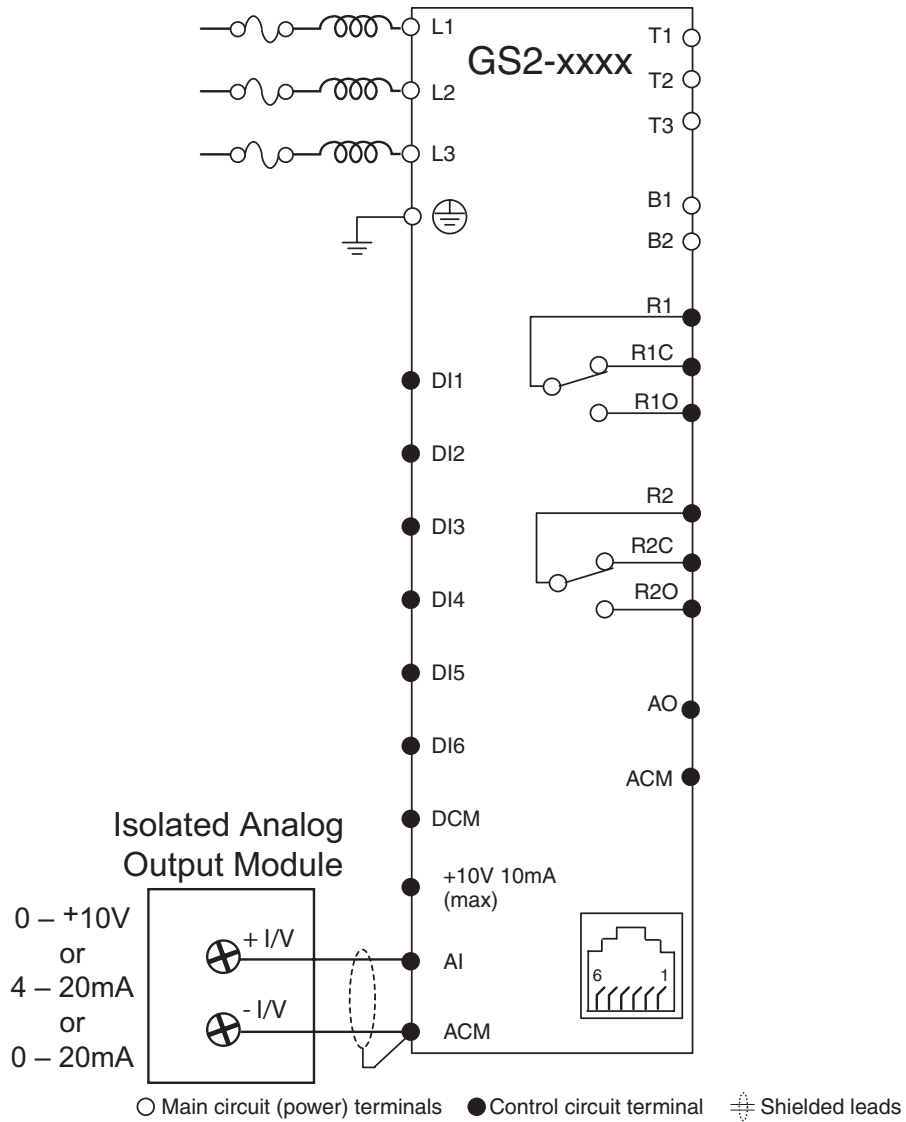

### Non-Isolated Voltage or Sourcing Current Analog Output Modules

- F0-02AD2DA-2
- F0-04AD2DA-1
- F0-04AD2DA-2
- F2-02DAS-1
- F2-02DAS-2
- F2-08DA-1
- F2-02DA-2
- F2-08DA-2
- F2-8AD4DA-1
- F2-8AD4DA-2
- F4-08DA-2
- F4-16DA-2
- T1F-08DA-2
- T1F-16DA-2
- T1F-8AD4DA-1
- T1F-8AD4DA-2

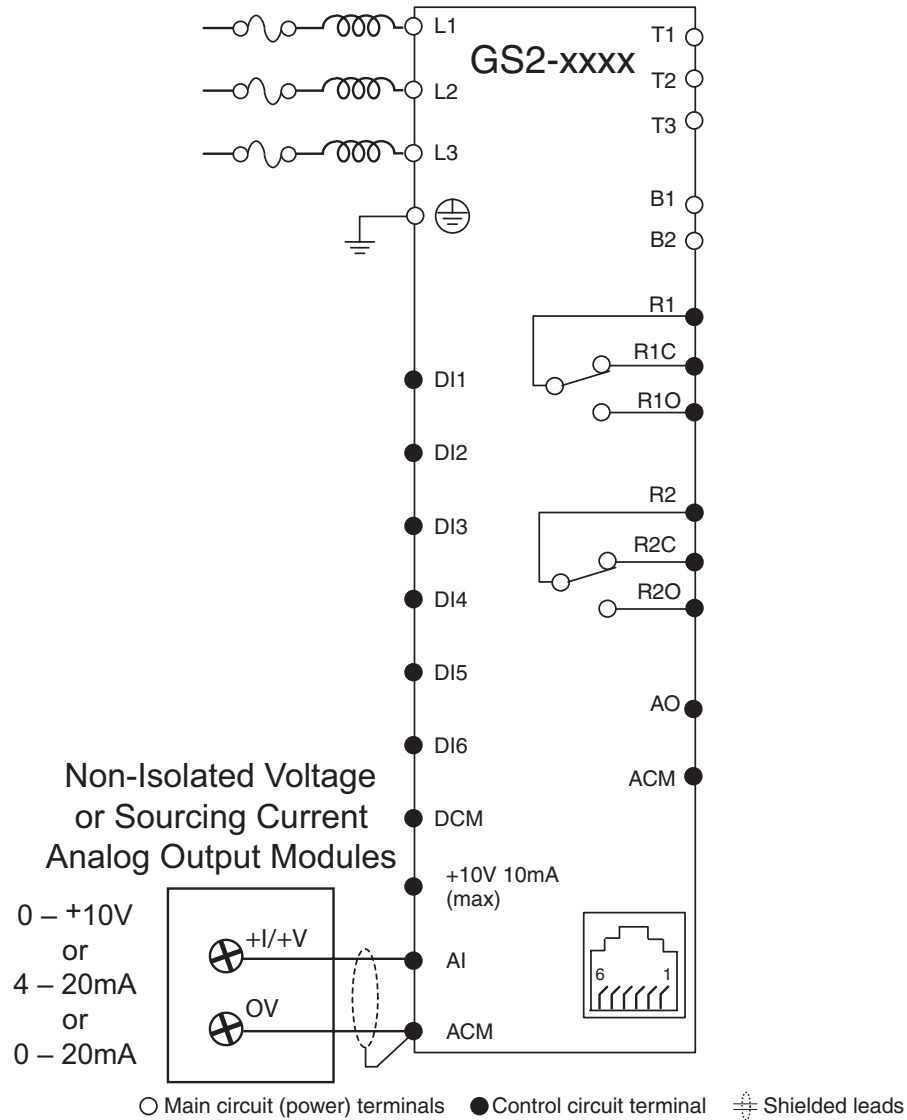



# INDEX

---



## A

AC Drives - Purpose; 1–3  
Accel 1 to Accel 2 Frequency Transition; 4–16  
Acceleration S-Curve; 4–14  
Acceleration Time; 4–13  
Accessories; 2–12, A–1  
AFD - Adjustable Frequency Drive; 1–3  
Agency Approvals; 1–8, 2–7  
Air Flow; 2–3  
Ambient Conditions; 1–8, 2–2  
Amps/Current  
    Motor Nameplate Amps; 4–11  
    Over-Current Stall Prevention; 4–47  
    Overload; 4–43  
Analog Input  
    Examples; 4–34  
    Gain; 4–33  
    Loss of ACI Signal; 4–40  
    Offset; 4–33  
    Offset Polarity; 4–32  
    Reverse Motion Enable; 4–33  
Analog Output; 4–40  
    Gain; 4–40  
    Signal; 4–40  
Analog Parameters; 4–32  
Applicable Codes; 2–7  
Auto Adjustable Accel/Decel; 4–46  
Auto Restart After Fault; 4–44

Auto Voltage Regulation; 4–45  
Auto-torque Boost; 4–20

## B

Base-Block Time for Speed Search; 4–48  
Block Transfer Parameters; 4–58, 5–29  
Braking Resistors; 2–12, A–8

## C

Cables  
    Configuration Cables; A–25  
    Keypad Cables; A–25  
CE; 1–8  
CEC; 2–7  
Circuit Connections Warnings & Notes; 2–6  
Communicating with DirectLogic PLCs; 5–12  
Communicating with Third-party Devices; 5–30  
Communication Address; 4–56  
Communication Connections to DL PLCs; 5–12  
Communication Distribution Blocks; A–26  
Communication Parameters; 4–56  
Communication Protocol; 4–56  
Communication Transmission Speed; 4–56  
Compatibility, GS2 and Direct LOGIC PLCs; B–2  
Configuration Cable; A–25  
Configuration Software; A–22  
    Configuration Cable; A–25

Configuring/Programming the AC Drive

Keypad Configuration; 3–5

Software Configuration; A–22

Configuration Cable; A–25

Contactor; 2–6, 2–12

Contents of Drive Package; 1–3

Control Terminals & Wiring; 1–4, 2–10, 2–11

cUL; 1–8, 2–7

Current/Amps

Motor Nameplate Amps; 4–11

Over-Current Stall Prevention; 4–47

Overload; 4–43

## D

DC Injection

Current Level; 4–18

during Start-up; 4–18

during Stopping; 4–18

Start-point; 4–18

Decel 1 to Decel 2 Frequency Transition; 4–16

Deceleration S-Curve; 4–15

Deceleration Time; 4–14

Default, Restore Parameters; 4–57

Desired Current; 4–31

Desired Frequency; 4–31

Dimensions; 2–4

Direction Command

Digital Input FWD/REV; 4–22

Keypad FWD/REV; 3–3

Serial Comm Direction Command; 4–59

DirectLOGIC Modbus PLC Programming; 5–16

DirectLOGIC PLCs; B–2

DirectLogic PLCs, Communicating with; 5–12

Disable

Digital Input Disable; 4–23, 4–29

Disable PID; 4–23

Disconnect switch; 2–6

Display; 3–2

Display Parameters; 4–55

Display Frequency Scale Factor; 4–55

Display Function; 4–55

Distribution Blocks, Communication; A–26

## E

Electro-Magnetic Interference; 2–7

EMI; 2–7

EMI Filters; 2–12, A–10

Enclosure Rating; 1–8, 2–2

Environmental Conditions; 1–8, 2–2

Error Codes; 5–9, 6–3

Ethernet Interface; A–20

Examples

Analog Input Examples; 4–34

DL PLC Program Example for Modbus; 5–16

External Fault

External Fault, Digital Input; 4–23, 4–24

External Fault, Serial Comm; 4–60

External Parts; 1–4

Cover - lower terminals; 1–4

Cover - upper terminals; 1–4

DIP Switches; 1–4

Keypad; 1–4

Mounting Screw Holes; 1–4

Nameplate Label; 1–4

Terminals - control wiring; 1–4

Terminals - power input wiring; 1–4

Terminals - power output wiring; 1–4

Ventilation Slots; 1–4

## F

Fault Codes; 6–3

Fault Record; 4–50

Fault Reset

External DI Fault Reset; 4–23, 4–24

Keypad Fault Reset; 3–3

Serial Comm Fault Reset; 4–60

Fault, External; 4–23, 4–24, 4–60

Filters

EMI Filters; 2–12, A–10

RF Filters; A–16



## Frequency

- Jog Frequency; 4-41
- Mid-point Frequency; 4-20
- Minimum Output Frequency; 4-21
- Motor Base Frequency; 4-12
- PID Output Frequency Limit; 4-54
- PWM Carrier Frequency; 4-21
- Source of Frequency Command; 4-32
- Volts/Hertz Parameters; 4-19

## Frequency Command / Speed Reference

- Serial Comm Speed Reference; 4-59
- Source of Frequency Command; 4-32

## Function Keys; 3-3

## Fuses; 2-12, A-17

**G**

## Ground Loops; 2-6

## Grounding Resistance; 2-6

## GS Series Number; 4-60

## GS-EDRV Ethernet Interface; A-20

## GSOFT Configuration Software; A-22

- Configuration Cable; A-25

**I**

## Inspection; 6-2

- Annual; 6-2
- Monthly; 6-2

## Installation; 2-3

- Air Flow; 2-3
- Dimensions; 2-4
- Minimum Clearances; 2-3

## Inverter; 1-3

**J**

## Jog Command

- Digital Input Jog Command; 4-23, 4-25
- Serial Comm Jog Command; 4-60

## Jog Frequency; 4-41

**K**

## Keypad; 3-2

## Keypad Cables; A-25

## Keypad, Spare; A-25

**L**

## Label, Nameplate Information; 1-3

## LED Display; 3-2

## LED Indicators; 3-2

## Lower Bound

- of Output Frequency; 4-49

**M**

## Maintenance; 6-2

## Manufacturer Model Information; 4-61

## Maximum Allowable Power Loss Time; 4-48

## Maximum Speed Search Current Level; 4-48

## Memory Addresses for Parameters; 5-4

## Mid-point Frequency; 4-20

## Mid-point Voltage; 4-20

## Minimum Clearances; 2-3

## Minimum Output Frequency; 4-21

## Minimum Output Voltage; 4-21

## Modbus ASCII; 5-30

## Modbus Communication with Third-Party Devices; 5-30

## Modbus Communications; 5-1

## Modbus Connections to DL PLCs; 5-12

## Modbus Control, PLC Programming; 5-16

## Modbus RTU; 5-30

## Model Information; 4-61

## Model Number Explanation; 1-3

## Momentary Power Loss; 4-44

## Motor Base Frequency; 4-12

## Motor Base RPM; 4-12

## Motor Maximum RPM; 4-12

## Motor Nameplate Amps; 4-11

## Motor Nameplate Voltage; 4-11

## Motor Parameters; 4-11

## Motors

- Single-Phase; 2–7
- Three-Phase; 1–3
- Mounting Screw Holes; 1–4, 2–4
- Multi-Function Input Disable; 4–29
- Multi-function Input Terminals; 4–22
- Multi-function Output Terminals; 4–30
- Multi-Speed
  - Auto Voltage Regulation; 4–45
  - Digital Input Multi-Speed Bits; 4–23, 4–25
  - Multi-Speed Settings; 4–42

## N

- Nameplate Label Information; 1–3
- NEC; 2–7
- NEMA Publications; 1–2

## O

- Operation Command; 4–22
- Over-Current
  - Stall Prevention During Acceleration; 4–47
  - Stall Prevention During Operation; 4–47
- Overload; 4–43
- Over-Torque
  - Detection Level; 4–46
  - Detection Mode; 4–46
  - Detection Time; 4–46
- Over-Voltage
  - Stall Prevention; 4–45

## P

- Parameter Lock; 4–57
- Parameter Memory Addresses; 5–4
- Parameter Summary; 4–2
- Parameters, Detailed Listings; 4–11
  - Restore Parameters to Default Settings; 4–57
- PID
  - PID Deviation Alarm; 4–30
  - PID Deviation Level; 4–31
  - PID Deviation Time; 4–31

- PID DI Setpoint Bits; 4–23, 4–25
- PID Deviation Alarm; 4–30
- PID Parameters; 4–51
  - Derivative Control; 4–53
  - Derivative Filter Time Constant; 4–54
  - Feedback Loss Operation; 4–54
  - Feedback Signal Loss Detection Time; 4–54
  - Input Terminal for PID Feedback; 4–51
  - Integral Control; 4–53
  - Keypad Setpoint; 4–52
  - Multi-setpoints; 4–52
  - Output Frequency Limit; 4–54
  - Proportional Control; 4–53
  - PV 100% Value; 4–52
  - PV Setpoint Source; 4–52
  - Upper Bound for Integral Control; 4–54
- PID SP Digital Inputs; 4–23
- PLC Module Typical Connections; B–7
- PLC Modules; B–2
- PLC Programming for Modbus Control; 5–16
- PLCs, DirectLOGIC, Communicating with; 5–12
- Potentiometer
  - Keypad Potentiometer; 3–3
  - Remote Potentiometer; 2–11
- Power Terminals & Wiring; 1–4, 2–7, 2–8, 2–9, 2–11
- Present Fault Record; 4–50
- Preset Parameters; 4–41
- Programming/Configuring the AC Drive
  - Keypad Configuration; 3–5
  - Software Configuration; A–22
    - Configuration Cable; A–25
- Protection Parameters; 4–43
- Purpose of AC Drives; 1–3
- PWM Carrier Frequency; 4–21

## R

- Ramp Parameters; 4–13
- Reactors; 2–12, A–2
- Reset, Fault

- External DI Fault Reset; 4-23, 4-24
  - Keypad Fault Reset; 3-3
  - Serial Comm Fault Reset; 4-60
  - Resistors, Braking; 2-12, A-8
  - Restore Parameters to Default Values; 4-57
  - Reverse Operation Inhibit; 4-44
  - RF Filters; A-16
  - RPM
    - Motor Base RPM; 4-12
    - Motor Maximum RPM; 4-12
  - RS-232 Communication Interface; 5-12, 5-30
    - RS-232 Selector DIP Switches; 1-4, 5-12, 5-30
    - RS-232 to RS-485 Conversion; 5-13
    - Wiring Connections to DL PLCs; 5-12
  - RS-485 Communication Interface; 5-13, 5-14, 5-30
    - RS-232 to RS-485 Conversion; 5-13
    - RS-485 Comm Distribution Board; A-26
    - RS-485 Selector DIP Switches; 1-4, 5-13, 5-30
    - Wiring Connections to DL PLCs; 5-13, 5-14
  - Run Command
    - Digital Input Run Command; 4-22
    - Keypad Run; 3-3
    - Serial Comm Run Command; 4-59
- ## S
- Safety Codes; 2-7
  - Select method for 2nd Accel/Decel; 4-16
  - Serial Comm Speed Reference; 4-59
  - Short Circuit Withstand Current; 2-7
  - Single-Phase Motors; 2-7
  - Skip Frequency; 4-17
  - Skip Frequency Band; 4-17
  - Slip Compensation; 4-20
  - Software, Configuration; A-22
    - Configuration Cable; A-25
  - Source of Frequency Command; 4-32
  - Source of Operation Command; 4-22
  - Special Symbols; 1-2
  - Specifications; 1-5
  - Speed Reference / Frequency Command
    - Serial Comm Speed Reference; 4-59
    - Source of Frequency Command; 4-32
  - Status Addresses; 5-9
  - Status Monitor; 5-9, 5-10
  - Status of the AC Drive
    - Keypad; 3-4
    - Serial Comm; 5-9
  - Stop
    - Digital Input Stop; 4-22
    - Keypad Stop; 3-3
  - Stop Methods; 4-13
  - Supplemental Publications; 1-2
    - NEMA Publications; 1-2
- ## T
- Technical Support; 1-2
  - Three-Phase Motors; 1-3
  - Time Out Detection; 4-57
  - Time Out Duration; 4-57
  - Torque
    - Over-Torque Detection; 4-46
  - Torque, Constant; 3-6
  - Torque, Variable; 3-11
  - Transmission Fault Treatment; 4-57
  - Troubleshooting; 6-3
- ## U
- UL; 1-8, 2-7
  - Upper Bound
    - for PID Integral Control; 4-54
    - of Output Frequency; 4-49
- ## V
- Ventilation Slots; 1-4
  - VFD - Variable Frequency Drive; 1-3
  - Voltage
    - Mid-point Voltage; 4-20

Minimum Output Voltage; 4-21  
Motor Nameplate Voltage; 4-11  
Over-Voltage Stall Prevention; 4-45  
Volts/Hertz Parameters; 4-19

Volts/Hertz Parameters; 4-19

## **W**

Warning Messages; 6-6  
Warnings & Notes - circuit connections; 2-6  
Warnings & Notes - general; 1-2  
Wiring & Circuit Connections; 2-6  
    Basic Wiring Diagram; 2-11  
    Control Circuit Wiring; 2-7, 2-10  
    Main Circuit Wiring; 2-7, 2-8, 2-9, 2-11  
    Serial Comm Wiring Connections; 5-12  
    Shielded Wiring; 2-10  
    Warnings; 2-6  
    Wiring Notes; 2-6  
Wiring Connections to DL PLC Modules; B-7



