

# IRONHORSE® HELICAL GEARBOX USER MANUAL

---

*IH-HGR\_UMW*

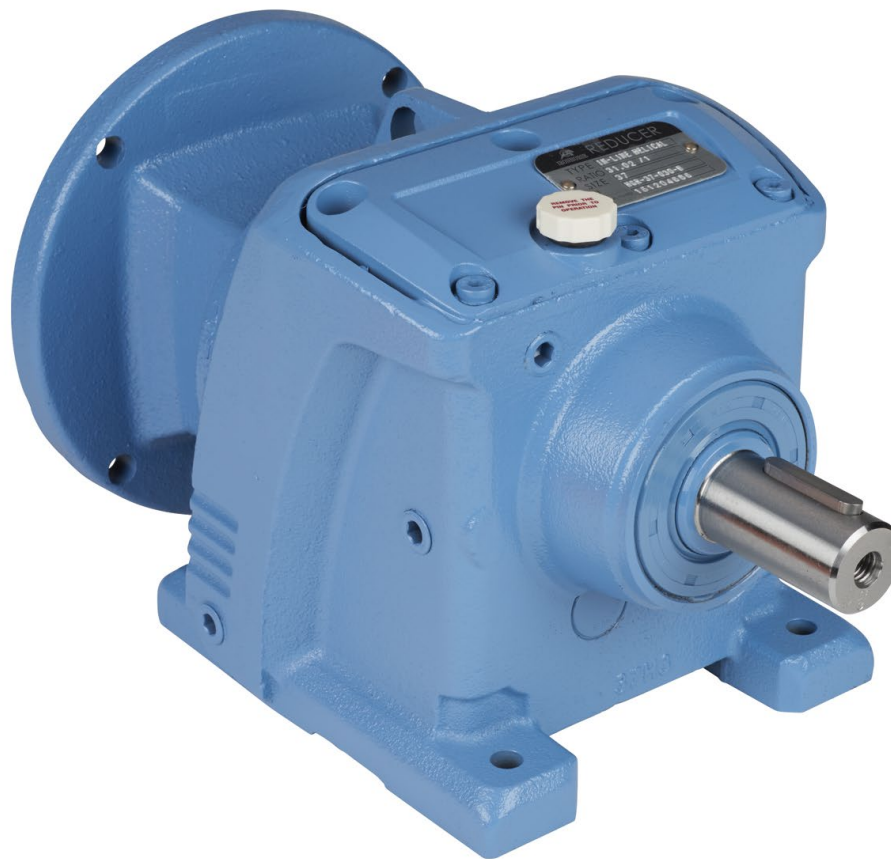

---

**BLANK  
PAGE**

## **WARNINGS AND TRADEMARKS**

### **~ WARNING ~**

Thank you for purchasing automation equipment from Automationdirect.com<sup>®</sup>, doing business as AutomationDirect. We want your new automation equipment to operate safely. Anyone who installs or uses this equipment should read this publication (and any other relevant publications) before installing or operating the equipment.

To minimize the risk of potential safety problems, you should follow all applicable local and national codes that regulate the installation and operation of your equipment. These codes vary from area to area and usually change with time. It is your responsibility to determine which codes should be followed, and to verify that the equipment, installation, and operation is in compliance with the latest revision of these codes.

At a minimum, you should follow all applicable sections of the National Fire Code, National Electrical Code, and the codes of the National Electrical Manufacturer's Association (NEMA). There may be local regulatory or government offices that can also help determine which codes and standards are necessary for safe installation and operation.

Equipment damage or serious injury to personnel can result from the failure to follow all applicable codes and standards. We do not guarantee the products described in this publication are suitable for your particular application, nor do we assume any responsibility for your product design, installation, or operation.

Our products are not fault-tolerant and are not designed, manufactured or intended for use or resale as on-line control equipment in hazardous environments requiring fail-safe performance, such as in the operation of nuclear facilities, aircraft navigation or communication systems, air traffic control, direct life support machines, or weapons systems, in which the failure of the product could lead directly to death, personal injury, or severe physical or environmental damage ("High Risk Activities"). AutomationDirect specifically disclaims any expressed or implied warranty of fitness for High Risk Activities.

For additional warranty and safety information, see the Terms and Conditions section of our catalog. If you have any questions concerning the installation or operation of this equipment, or if you need additional information, please call us at **770-844-4200**.

This publication is based on information that was available at the time it was printed. At AutomationDirect we constantly strive to improve our products and services, so we reserve the right to make changes to the products and/or publications at any time without notice and without any obligation. This publication may also discuss features that may not be available in certain revisions of the product.

### **TRADEMARKS**

This publication may contain references to products produced and/or offered by other companies. The product and company names may be trademarked and are the sole property of their respective owners. AutomationDirect disclaims any proprietary interest in the marks and names of others.

***COPYRIGHT 2018, 2019 AUTOMATIONDIRECT.COM<sup>®</sup> INCORPORATED  
ALL RIGHTS RESERVED***

No part of this manual shall be copied, reproduced, or transmitted in any way without the prior, written consent of Automationdirect.com<sup>®</sup> Incorporated. AutomationDirect retains the exclusive rights to all information included in this document.

## ~ AVERTISSEMENT ~

Nous vous remercions d'avoir acheté l'équipement d'automatisation de Automationdirect.com<sup>®</sup>, en faisant des affaires comme AutomationDirect. Nous tenons à ce que votre nouvel équipement d'automatisation fonctionne en toute sécurité. Toute personne qui installe ou utilise cet équipement doit lire la présente publication (et toutes les autres publications pertinentes) avant de l'installer ou de l'utiliser.

Afin de réduire au minimum le risque d'éventuels problèmes de sécurité, vous devez respecter tous les codes locaux et nationaux applicables régissant l'installation et le fonctionnement de votre équipement. Ces codes diffèrent d'une région à l'autre et, habituellement, évoluent au fil du temps. Il vous incombe de déterminer les codes à respecter et de vous assurer que l'équipement, l'installation et le fonctionnement sont conformes aux exigences de la version la plus récente de ces codes.

Vous devez, à tout le moins, respecter toutes les sections applicables du Code national de prévention des incendies, du Code national de l'électricité et des codes de la National Electrical Manufacturer's Association (NEMA). Des organismes de réglementation ou des services gouvernementaux locaux peuvent également vous aider à déterminer les codes ainsi que les normes à respecter pour assurer une installation et un fonctionnement sûrs.

L'omission de respecter la totalité des codes et des normes applicables peut entraîner des dommages à l'équipement ou causer de graves blessures au personnel. Nous ne garantissons pas que les produits décrits dans cette publication conviennent à votre application particulière et nous n'assumons aucune responsabilité à l'égard de la conception, de l'installation ou du fonctionnement de votre produit.

Nos produits ne sont pas insensibles aux défaillances et ne sont ni conçus ni fabriqués pour l'utilisation ou la revente en tant qu'équipement de commande en ligne dans des environnements dangereux nécessitant une sécurité absolue, par exemple, l'exploitation d'installations nucléaires, les systèmes de navigation aérienne ou de communication, le contrôle de la circulation aérienne, les équipements de survie ou les systèmes d'armes, pour lesquels la défaillance du produit peut provoquer la mort, des blessures corporelles ou de graves dommages matériels ou environnementaux («activités à risque élevé»). La société AutomationDirect nie toute garantie expresse ou implicite d'aptitude à l'emploi en ce qui a trait aux activités à risque élevé.

Pour des renseignements additionnels touchant la garantie et la sécurité, veuillez consulter la section Modalités et conditions de notre documentation. Si vous avez des questions au sujet de l'installation ou du fonctionnement de cet équipement, ou encore si vous avez besoin de renseignements supplémentaires, n'hésitez pas à nous téléphoner au 770-844-4200.

Cette publication s'appuie sur l'information qui était disponible au moment de l'impression. À la société AutomationDirect, nous nous efforçons constamment d'améliorer nos produits et services. C'est pourquoi nous nous réservons le droit d'apporter des modifications aux produits ou aux publications en tout temps, sans préavis ni quelque obligation que ce soit. La présente publication peut aussi porter sur des caractéristiques susceptibles de ne pas être offertes dans certaines versions révisées du produit.

## MARQUES DE COMMERCE

La présente publication peut contenir des références à des produits fabriqués ou offerts par d'autres entreprises. Les désignations des produits et des entreprises peuvent être des marques de commerce et appartiennent exclusivement à leurs propriétaires respectifs. AutomationDirect nie tout intérêt dans les autres marques et désignations.

***COPYRIGHT 2018, 2019 AUTOMATIONDIRECT.COM<sup>®</sup> INCORPORATED***

***TOUS DROITS RÉSERVÉS***

Nulle partie de ce manuel ne doit être copiée, reproduite ou transmise de quelque façon que ce soit sans le consentement préalable écrit de la société Automationdirect.com<sup>®</sup> Incorporated. AutomationDirect conserve les droits exclusifs à l'égard de tous les renseignements contenus dans le présent document.

# IRONHORSE® HELICAL GEARBOX USER MANUAL



---

## **USER MANUAL REVISION HISTORY**

Please include this Manual Number and the Manual Issue, both shown below, when communicating with AutomationDirect Technical Support regarding this publication.

**MANUAL NUMBER:**            **IH-HGR\_UMW**

**MANUAL ISSUE:**            **THIRD EDITION**

**ISSUE DATE:**                **10/03/2019**

<b>Publication History</b>		
<b>Issue</b>	<b>Date</b>	<b>Description of Changes</b>
First Edition	06/02/2016	Original Issue
1st Edition Rev. A	06/07/2016	Revised dimensional drawing
1st Edition Rev. B	10/09/2018	Added additional installation information in chapter 3
Second Edition	06/07/2019	User manual formatting and name change (was "IH-HG-USER-M-WO") Ch3: Brass vent plug
2nd Edition Rev. A	08/30/2019	Ch3: Bearing and seal sizes
Third Edition	10/03/2019	Ch2: Revised efficiency specs; Added new breather plug accessories

**BLANK  
PAGE**

# IRONHORSE® HELICAL GEARBOX USER MANUAL TABLE OF CONTENTS

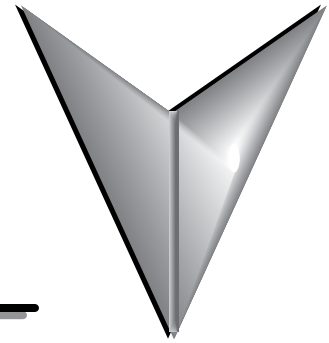

---

## IRONHORSE HELICAL GEARBOX USER MANUAL

<i>WARNINGS AND TRADEMARKS</i> . . . . .	W-1
~ WARNING ~ . . . . .	W-1
Trademarks. . . . .	W-1
~ AVERTISSEMENT ~ . . . . .	W-2
Marques de commerce . . . . .	W-2
<i>USER MANUAL REVISION HISTORY.</i> . . . . .	H-1
<i>USER MANUAL TABLE OF CONTENTS.</i> . . . . .	TOC-1
<i>CHAPTER 1: GETTING STARTED</i> . . . . .	1-1
Manual Overview . . . . .	1-2
IronHorse® Helical Gearbox Introduction. . . . .	1-3
Part Number Explanation. . . . .	1-4
Nameplate Information. . . . .	1-4
<i>CHAPTER 2: SPECIFICATIONS</i> . . . . .	2-1
Gearbox Selection Factors . . . . .	2-2
IronHorse® Cast-Iron Helical Gearbox Specifications . . . . .	2-3
IronHorse® Cast-Iron Helical Gearbox Accessories. . . . .	2-7
IronHorse Cast-Iron Helical Gearbox Dimensions . . . . .	2-8
<i>CHAPTER 3: INSTALLATION, MAINTENANCE, AND LUBRICATION</i> . . . . .	3-1
Safety Notification. . . . .	3-2
Installation. . . . .	3-3
Mounting Positions . . . . .	3-4
Starting Up. . . . .	3-4
Inspection and Maintenance . . . . .	3-4
Lubrication. . . . .	3-5
Filler / Oil Gauge / Drain Plug Locations . . . . .	3-6
Recommended Lubricant. . . . .	3-7
Recommended Lubricant Amount by Box Size and Mounting Position . . . . .	3-7
Seal Sizes. . . . .	3-8
Bearing Sizes. . . . .	3-8
Storage. . . . .	3-9
<i>APPENDIX A: GLOSSARY OF TERMS</i> . . . . .	A-1
Glossary of Gearbox Terms. . . . .	A-2
<i>APPENDIX B: GEARBOX SELECTION</i> . . . . .	B-1
Gearbox Selection Procedure. . . . .	B-2

BLANK  
PAGE



# GETTING STARTED

---

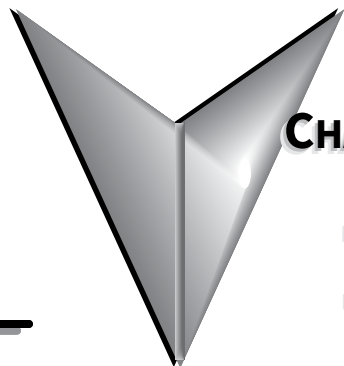

## CHAPTER

# 1

### TABLE OF CONTENTS

<i>Manual Overview</i> . . . . .	.1-2
<i>Overview of This Publication</i> . . . . .	1-2
<i>Who Should Read This Manual.</i> . . . . .	1-2
<i>Technical Support</i> . . . . .	1-2
<i>Special Symbols</i> . . . . .	1-2
<i>IronHorse® Helical Gearbox Introduction.</i> . . . . .	.1-3
<i>Purpose of Helical Gearboxes.</i> . . . . .	1-3
<i>Package Contents</i> . . . . .	1-3
<i>Part Number Explanation</i> . . . . .	.1-4
<i>Nameplate Information</i> . . . . .	.1-4

---

## MANUAL OVERVIEW

### OVERVIEW OF THIS PUBLICATION

The IronHorse Helical Gearbox User Manual describes the installation, operation, and preventative maintenance of IronHorse Helical Gearboxes.

### WHO SHOULD READ THIS MANUAL

This manual contains important information for people who will install, maintain, and/or operate any of the IronHorse Helical Gearboxes.

### TECHNICAL SUPPORT

Our technical support group is glad to work with you to answer your questions. Please call the technical support group if you need technical assistance, or visit our web site. Our website contains technical and non-technical information about our products and our company.

**By telephone: (770) 844-4200 (Mon – Fri, 9:00 am – 6:00 pm ET)**

**On the Web: [www.automationdirect.com](http://www.automationdirect.com)**

### SPECIAL SYMBOLS



---

*When you see the “notepad” icon in the left-hand margin, the paragraph to its immediate right will be a special note.*

---



---

*WHEN YOU SEE THE “EXCLAMATION MARK” ICON IN THE LEFT-HAND MARGIN, THE PARAGRAPH TO ITS IMMEDIATE RIGHT WILL BE A WARNING. THIS INFORMATION COULD PREVENT INJURY, LOSS OF PROPERTY, OR EVEN DEATH (IN EXTREME CASES).*

---

## IRONHORSE® HELICAL GEARBOX INTRODUCTION

### ***PURPOSE OF HELICAL GEARBOXES***

Gearboxes, also known as enclosed gear drives or speed reducers, are mechanical drive components that can control a load at a reduced fixed ratio of the motor speed. The output torque is also increased by the same ratio, while the horsepower remains the same (less efficiency losses). For example, a 10:1 ratio gearbox outputs approximately the same motor output horsepower, but motor speed is divided by 10, and motor torque is multiplied by 10. Helical gearboxes use helical gears to provide quiet startup and smooth operation. IronHorse helical gearboxes are manufactured in an ISO9001 certified plant by one of the leading and most internationally acclaimed gearbox manufacturers in the world today. Only the highest quality materials are tested, certified, and used in the manufacturing process. Strict adherence to and compliance with the toughest international and U.S. testing standards and manufacturing procedures assure you the highest quality products. We offer straight-through helical gearboxes with cast-iron frames. The output shaft is parallel to the input. Our gearboxes utilize C-face and TC-face mounting interfaces for C-face and TC-face motors.

### ***PACKAGE CONTENTS***

After receiving the IronHorse Helical Gearbox, please check for the following:

- *Make sure the package includes the speed reducer and the vent plug.*
- *Inspect the unit to insure it was not damaged during shipment.*
- *Make sure that the part number on the gearbox nameplate is the same as the part number that you ordered.*
- *Gearboxes come pre-filled with oil for an M1 mounting position. Check oil level and fill per instructions when changing to a different mounting position.*

**PART NUMBER EXPLANATION**

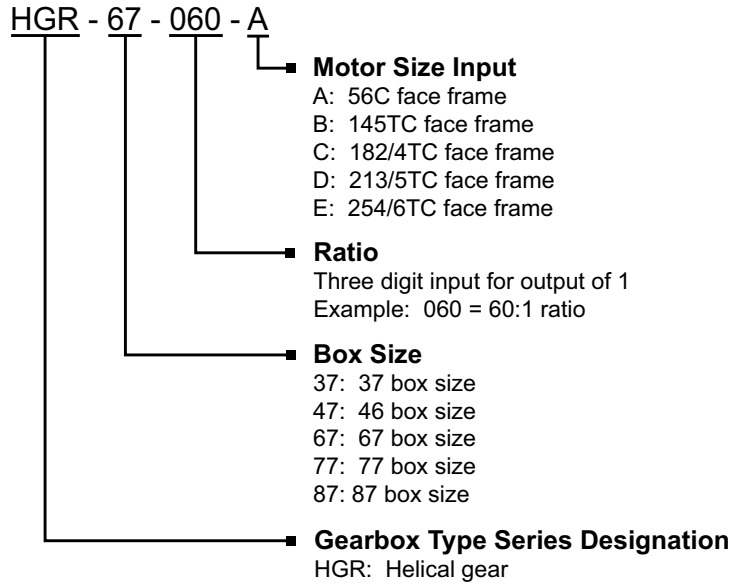

**NAMEPLATE INFORMATION**

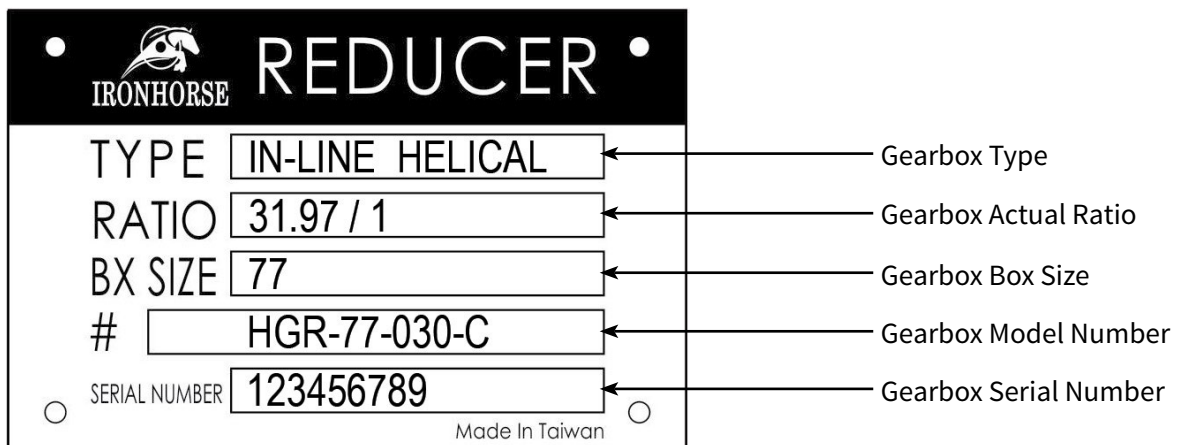

# SPECIFICATIONS

---

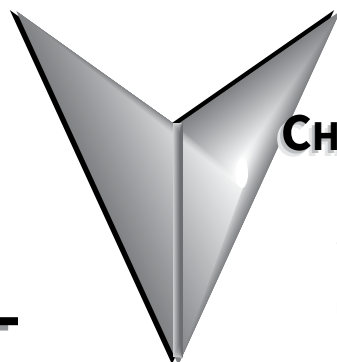

## CHAPTER

# 2

### TABLE OF CONTENTS

<i>Gearbox Selection Factors</i> . . . . .	.2-2
<i>Service Factors and K Factors</i> . . . . .	2-2
<i>IronHorse® Cast-Iron Helical Gearbox Specifications</i> . . . . .	.2-3
<i>IronHorse® Cast-Iron Helical Gearbox Accessories</i> . . . . .	.2-7
<i>Breather Plugs (Spare/Replacement)</i> . . . . .	2-7
<i>IronHorse Cast-Iron Helical Gearbox Dimensions</i> . . . . .	.2-8

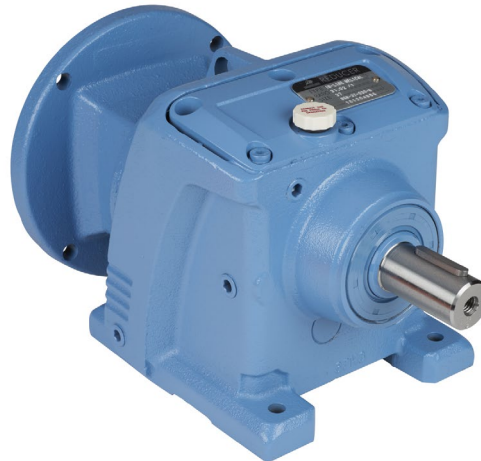

## GEARBOX SELECTION FACTORS

### SERVICE FACTORS AND K FACTORS

Service Factors for Selecting Gearboxes (when used with electric motors)				
Service Continuity (per day)	Load Characteristics			
	Uniform	Moderate Shock*	Heavy Shock*	Extreme Shock*
Occasional 1/2 hour	1.00	1.00	1.00	1.25
Less than 3 hours	1.00	1.00	1.25	1.50
3-10 hours	1.00	1.25	1.50	1.75
More than 10 hours	1.25	1.50	1.75	2.00
* Shock results from sudden increases in the torque demand of the load, such as: sudden stopping, restarting, and/or reversing; significantly heavy loads dropped onto a moving conveyor; impact loads such as punch press operations.				
Depending upon the load characteristics, divide the gearbox HP, Overhung Load, and Maximum Mechanical Capacity ratings by the applicable service factor.				

Overhung Load K Factors for Various Drive Types	
Chain & Sprocket	1.00
Gear	1.25
V-belt	1.50
Flat Belt	2.50
Variable Pitch Belt	3.50
Divide gearbox OHL ratings by the applicable OHL K factors.	

**IRONHORSE® CAST-IRON HELICAL GEARBOX SPECIFICATIONS**

IronHorse Cast-Iron Helical Gearbox Specifications – Box Size 37												
Part Number	Nominal Ratio	Actual Ratio	Output RPM @ 1750 rpm Input	Nominal HP @ 1.0 Service Factor 1	NEMA Motor Frame	Output Shaft Diameter (in)	Input Power (hp)	Output Torque (lb-in)	OHL (lbs) <sup>2</sup>	Stages	Efficiency (%)	Approx Weight (lb)
HGR-37-005-A	5:1	4.88	359	1.0	56C	1	5.91	970	305	2	96	32
HGR-37-005-B				2.0	145TC							
HGR-37-010-A	10:1	10.02	175	1.0	56C							
HGR-37-010-B				2.0	145TC							
HGR-37-015-A	15:1	15.75	111	1.0	56C							
HGR-37-015-B				2.0	145TC							
HGR-37-020-A	20:1	19.95	88	1.0	56C							
HGR-37-020-B				2.0	145TC							
HGR-37-030-A	30:1	31.02	56	1.5	56C							
HGR-37-030-B				2.0	145TC							
HGR-37-040-A	40:1	40.08	44	1.0	56C		1.75	1770	565	3	94	
HGR-37-060-A	60:1	60.84	29	1.0	56C		1.35	1770	615			
							0.89	1770	705			

1) Nominal Motor HP is the highest HP 1800 rpm motor to be used with the gearbox under conditions of 1.0 service factor. Gearbox input power capacity decreases as motor speed decreases and as service factor increases.

2) OHL = Overhung Load ratings are for forces perpendicular to the output shaft and located at the shaft midpoint, such as from a gear, pulley, or sprocket with a belt or chain. Divide OHL ratings by the applicable OHL K factors shown separately in the Selection Factors tables. OHL ratings should also be divided by applicable service factors.

3) Maximum Mechanical Ratings are limits based on strength and durability of gearbox components; applicable when operating time is short and stopped time is greater than or equal to operating time. These ratings are applicable for 1.0 service factor loads, and may require modification depending upon characteristics of the applicable driven loads. Refer to the "Service Factors" table for more information.

**IRONHORSE CAST-IRON HELICAL GEARBOX SPECIFICATIONS (CONTINUED)**

IronHorse Cast-Iron Helical Gearbox Specifications – Box Size 47												
Part Number	Nominal Ratio	Actual Ratio	Output RPM @ 1750 rpm Input	Nominal HP @ 1.0 Service Factor 1	NEMA Motor Frame	Output Shaft Diameter (in)	Input Power (hp)	Output Torque (lb-in)	OHL (lbs) <sup>2</sup>	Stages	Efficiency (%)	Approx Weight (lb)
HGR-47-005-B	5:1	4.85	361	2.0	145TC	1-1/4	9.59	1565	440	2	96	45
HGR-47-005-C				5.0	182/4TC							51
HGR-47-010-C	10:1	11.27	155	3.0	182TC		5.95	2255	590			45
HGR-47-015-C	15:1	15.18	115	3.0	182TC		4.87	2490	650			51
HGR-47-020-B	20:1	18.37	95	2.0	145TC		4.29	2650	690			45
HGR-47-020-C				3.0	182TC							51
HGR-47-030-B	30:1	31.83	55	2.0	145TC		3	2.73	2830	835	94	45
HGR-47-030-C				3.0	182/4TC							51
HGR-47-040-A	40:1	41.51	42	1.0	56C			2.09	2830	910		45
HGR-47-060-A	60:1	63.37	28	1.0	56C			1.37	2830	1050		45

1) Nominal Motor HP is the highest HP 1800 rpm motor to be used with the gearbox under conditions of 1.0 service factor. Gearbox input power capacity decreases as motor speed decreases and as service factor increases.

2) OHL = Overhung Load ratings are for forces perpendicular to the output shaft and located at the shaft midpoint, such as from a gear, pulley, or sprocket with a belt or chain. Divide OHL ratings by the applicable OHL K factors shown separately in the Selection Factors tables. OHL ratings should also be divided by applicable service factors.

3) Maximum Mechanical Ratings are limits based on strength and durability of gearbox components; applicable when operating time is short and stopped time is greater than or equal to operating time. These ratings are applicable for 1.0 service factor loads, and may require modification depending upon characteristics of the applicable driven loads. Refer to the "Service Factors" table for more information.



**IRONHORSE CAST-IRON HELICAL GEARBOX SPECIFICATIONS (CONTINUED)**

IronHorse Cast-Iron Helical Gearbox Specifications – Box Size 67												
Part Number	Nominal Ratio	Actual Ratio	Output RPM @ 1750 rpm Input	Nominal HP @ 1.0 Service Factor 1	NEMA Motor Frame	Output Shaft Diameter (in)	Input Power (hp)	Output Torque (lb-in)	OHL (lbs)2	Stages	Efficiency (%)	Approx Weight (lb)
HGR-67-005-B	5:1	5.23	335	2.0	145TC	1-3/8	15.38	2710	710	2	96	63
HGR-67-005-C				5.0	182/4TC							69
HGR-67-010-C	10:1	9.90	177	5.0	182/4TC		12.39	4130	880			63
HGR-67-015-B	15:1	15.41	114	2.0	145TC		9.23	4785	1020			69
HGR-67-015-C				3.0	182TC							
HGR-67-020-C	20:1	22.90	76	5.0	182/4TC		6.87	4720	1165	3	94	63
HGR-67-030-B	30:1	32.02	55	2.0	145TC		4.83	5045	1305			
HGR-67-040-B	40:1	41.22	42	2.0	145TC		3.75	5045	1420			
HGR-67-060-A	60:1	63.07	28	1.0	56C		2.45	5045	1480			

1) Nominal Motor HP is the highest HP 1800 rpm motor to be used with the gearbox under conditions of 1.0 service factor. Gearbox input power capacity decreases as motor speed decreases and as service factor increases.

2) OHL = Overhung Load ratings are for forces perpendicular to the output shaft and located at the shaft midpoint, such as from a gear, pulley, or sprocket with a belt or chain. Divide OHL ratings by the applicable OHL K factors shown separately in the Selection Factors tables. OHL ratings should also be divided by applicable service factors.

3) Maximum Mechanical Ratings are limits based on strength and durability of gearbox components; applicable when operating time is short and stopped time is greater than or equal to operating time. These ratings are applicable for 1.0 service factor loads, and may require modification depending upon characteristics of the applicable driven loads. Refer to the "Service Factors" table for more information.

**IRONHORSE CAST-IRON HELICAL GEARBOX SPECIFICATIONS (CONTINUED)**

IronHorse Cast-Iron Helical Gearbox Specifications – Box Size 77												
Part Number	Nominal Ratio	Actual Ratio	Output RPM @ 1750 rpm Input	Nominal HP @ 1.0 Service Factor 1	NEMA Motor Frame	Output Shaft Diameter (in)	Input Power (hp)	Output Torque (lb-in)	OHL (lbs)2	Stages	Efficiency (%)	Approx Weight (lb)
<b>HGR-77-005-C</b>	5:1	4.78	366	5.0	182/4TC	1-5/8	25.13	4040	785	2	96	82
<b>HGR-77-005-D</b>				7.5	213/5TC							93
<b>HGR-77-010-D</b>	10:1	10.91	160	7.5	213/5TC		16.89	6205	1035			
<b>HGR-77-020-C</b>	20:1	23.31	75	5.0	182/4TC		7.84	6150	1330			
<b>HGR-77-030-C</b>	30:1	31.97	55	5.0	182/4TC		6.36	6640	1480	3	94	82
<b>HGR-77-040-C</b>	40:1	39.31	45	3.0	182TC		5.49	6640	1555			
<b>HGR-77-060-B</b>	60:1	57.73	30	2.0	145TC		3.52	6640	1800			76

1) Nominal Motor HP is the highest HP 1800 rpm motor to be used with the gearbox under conditions of 1.0 service factor. Gearbox input power capacity decreases as motor speed decreases and as service factor increases.

2) OHL = Overhung Load ratings are for forces perpendicular to the output shaft and located at the shaft midpoint, such as from a gear, pulley, or sprocket with a belt or chain. Divide OHL ratings by the applicable OHL K factors shown separately in the Selection Factors tables. OHL ratings should also be divided by applicable service factors.

3) Maximum Mechanical Ratings are limits based on strength and durability of gearbox components; applicable when operating time is short and stopped time is greater than or equal to operating time. These ratings are applicable for 1.0 service factor loads, and may require modification depending upon characteristics of the applicable driven loads. Refer to the "Service Factors" table for more information.

**IRONHORSE CAST-IRON HELICAL GEARBOX SPECIFICATIONS (CONTINUED)**

IronHorse Cast-Iron Helical Gearbox Specifications – Box Size 87														
Part Number	Nominal Ratio	Actual Ratio	Output RPM @ 1750 rpm Input	Nominal HP @ 1.0 Service Factor 1	NEMA Motor Frame	Output Shaft Diameter (in)	Input Power (hp)	Output Torque (lb-in)	OHL (lbs)2	Stages	Efficiency (%)	Approx Weight (lb)		
HGR-87-005-D	5:1	4.73	370	10.0	213/5TC	2-1/8	38.49	6120	1800	2	96	163		
HGR-87-005-E				20.0	254/6TC							169		
HGR-87-010-D	10:1	10.66	164	10.0	213/5TC							27.28	9790	2375
HGR-87-015-D	15:1	15.29	114	10.0	213/5TC		21.45	11040	2680					
HGR-87-020-C	20:1	20.06	87	5.0	182/4TC		15.13	9915	2925			3	94	156
HGR-87-020-D				10.0	213/5TC									163
HGR-87-030-C	30:1	31.73	55	5.0	182/4TC		11.15	11550	3010	156				
HGR-87-040-C	40:1	38.20	46	5.0	182/4TC		11.36	14170	3010	150				
HGR-87-060-B	60:1	61.54	28	2.0	145TC		7.05	14170	3010	156				
HGR-87-060-C				5.0	182/4TC					156				

1) Nominal Motor HP is the highest HP 1800 rpm motor to be used with the gearbox under conditions of 1.0 service factor. Gearbox input power capacity decreases as motor speed decreases and as service factor increases.

2) OHL = Overhung Load ratings are for forces perpendicular to the output shaft and located at the shaft midpoint, such as from a gear, pulley, or sprocket with a belt or chain. Divide OHL ratings by the applicable OHL K factors shown separately in the Selection Factors tables. OHL ratings should also be divided by applicable service factors.

3) Maximum Mechanical Ratings are limits based on strength and durability of gearbox components; applicable when operating time is short and stopped time is greater than or equal to operating time. These ratings are applicable for 1.0 service factor loads, and may require modification depending upon characteristics of the applicable driven loads. Refer to the "Service Factors" table for more information.

**IRONHORSE® CAST-IRON HELICAL GEARBOX ACCESSORIES**

**BREATHER PLUGS (SPARE/REPLACEMENT)**



**Breather Plug (typical)**

IronHorse Cast-Iron Helical Gearbox Breather Plugs *		
Part Number	Description	For Use With:
HBR-3777V	IronHorse breather plug, replacement. For use with size 37 through 77 HGR- and HBR-series gearboxes.	HB(G)R-37-xx through HB(G)R-77-xx
HBR-8797V	IronHorse breather plug, replacement. For use with size 87 and larger HGR- and HBR-series gearboxes.	HB(G)R-87-xx

\* These items are included with the gearboxes, and are also available separately as spare or replacement parts.

### IRONHORSE CAST-IRON HELICAL GEARBOX DIMENSIONS

See our website [www.AutomationDirect.com](http://www.AutomationDirect.com) for complete Engineering drawings.

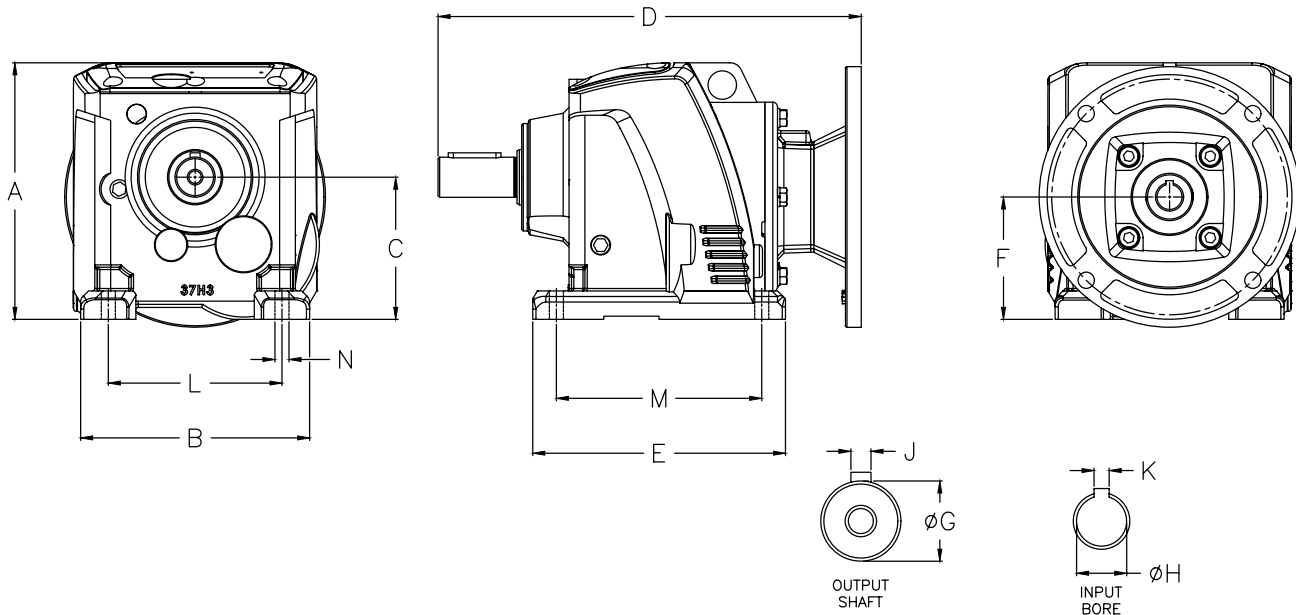

Dimensions – inches [mm] – IronHorse Cast-Iron Helical Gearboxes														
Part Number	Frame	A	B	C	D	E	F	G	H	J	K	L	M	N
HGR-37-xxx-A	56C	6.40 [162.5]	5.71 [145.0]	3.54 [90.0]	10.55 [268.0]	6.30 [160.0]	3.05 [77.5]	1.00 [25.4]	0.63 [15.9]	0.25 [6.4]	0.19 [4.8]	4.33 [110.0]	5.12 [130.0]	0.35 [8.9]
HGR-47-xxx-A		8.25 [209.5]	6.69 [170.0]	4.53 [115.0]	11.63 [295.4]	7.68 [195.0]	3.98 [101.0]	1.25 [31.8]				5.31 [134.9]	6.50 [165.1]	0.55 [14.0]
HGR-67-xxx-A		8.89 [226.0]	8.27 [210.0]	5.12 [130.0]	13.13 [333.5]	9.25 [235.0]	4.45 [113.0]	1.38 [34.9]				5.91 [150.1]	7.68 [195.1]	
HGR-37-xxx-B	145TC	6.40 [162.5]	5.71 [145.0]	3.54 [90.0]	10.94 [278.0]	6.30 [160.0]	3.05 [77.5]	1.00 [25.4]	0.88 [22.2]	0.25 [6.4]	0.19 [4.8]	4.33 [110.0]	5.12 [130.0]	0.35 [8.9]
HGR-47-xxx-B		8.25 [209.5]	6.69 [170.0]	4.53 [115.0]	12.03 [305.5]	7.68 [195.0]	3.98 [101.0]	1.25 [31.8]				5.31 [134.9]	6.50 [165.1]	0.55 [14.0]
HGR-67-xxx-B		8.89 [226.0]	8.27 [210.0]	5.12 [130.0]	13.52 [343.5]	9.25 [235.0]	4.45 [113.0]	1.38 [34.9]				5.91 [150.1]	7.68 [195.1]	
HGR-77-xxx-B		10.04 [255.0]	9.06 [230.0]	5.51 [140.0]	14.23 [361.5]	9.65 [245.0]	6.38 [162.0]	1.63 [41.4]				6.69 [170.0]	8.07 [205.0]	0.71 [18.0]
HGR-87-xxx-B		12.99 [330.0]	11.42 [290.0]	7.09 [180.0]	17.20 [437.0]	12.20 [310.0]	8.05 [204.5]	2.13 [54.1]		0.50 [12.7]		8.46 [215.0]	10.24 [260.0]	
HGR-47-xxx-C	182/4TC*	8.25 [209.5]	6.69 [170.0]	4.53 [115.0]	12.76 [324.0]	7.68 [195.0]	3.98 [101.0]	1.25 [31.8]	1.13 [28.7]	0.25 [6.4]	0.25 [6.4]	5.31 [134.9]	6.50 [165.1]	0.55 [14.0]
HGR-67-xxx-C		8.89 [226.0]	8.27 [210.0]	5.12 [130.0]	14.25 [362.0]	9.25 [235.0]	4.45 [113.0]	1.38 [34.9]				5.91 [150.1]	7.68 [195.1]	
HGR-77-xxx-C		10.04 [255.0]	9.06 [230.0]	5.51 [140.0]	14.96 [380.0]	9.65 [245.0]	6.38 [162.0]	1.63 [41.4]				6.69 [170.0]	8.07 [205.0]	0.71 [18.0]
HGR-87-xxx-C		12.99 [330.0]	11.42 [290.0]	7.09 [180.0]	17.32 [440.0]	12.20 [310.0]	8.05 [204.5]	2.13 [54.1]				8.46 [215.0]	10.24 [260.0]	
HGR-77-xxx-D	213/5TC	10.04 [255.0]	9.06 [230.0]	5.51 [140.0]	17.22 [437.5]	9.65 [245.0]	6.38 [162.0]	1.63 [41.4]	1.38 [35.0]	0.38 [9.7]	0.31 [7.9]	6.69 [170.0]	8.07 [205.0]	0.71 [18.0]
HGR-87-xxx-D		12.99 [330.0]	11.42 [290.0]	7.09 [180.0]	19.59 [497.5]	12.20 [310.0]	8.05 [204.5]	2.13 [54.1]				8.46 [215.0]	10.24 [260.0]	
HGR-87-xxx-E	254/6TC	12.99 [330.0]	11.42 [290.0]	7.09 [180.0]	20.57 [522.5]	12.20 [310.0]	8.05 [204.5]	2.13 [54.1]	1.63 [41.4]	0.50 [12.7]	0.38 [9.7]	8.46 [215.0]	10.24 [260.0]	0.71 [18.0]

\*Note: 184TC motor frame sizes where applicable. See gearbox specifications for more information.

# INSTALLATION, MAINTENANCE, AND LUBRICATION

---



## CHAPTER

# 3

### TABLE OF CONTENTS

<i>Safety Notification</i> . . . . .	.3-2
<i>Installation</i> . . . . .	.3-3
<i>Mounting Positions</i> . . . . .	.3-4
<i>Starting Up</i> . . . . .	.3-4
<i>Inspection and Maintenance</i> . . . . .	.3-4
<i>Lubrication</i> . . . . .	.3-5
<i>Filler / Oil Gauge / Drain Plug Locations</i> . . . . .	.3-6
<i>Recommended Lubricant</i> . . . . .	.3-7
<i>CPC E.P. LUBRICANT HD</i> . . . . .	3-7
<i>Recommended Lubricant Amount by Box Size and Mounting Position</i> . . . . .	.3-7
<i>Seal Sizes</i> . . . . .	.3-8
<i>Bearing Sizes</i> . . . . .	.3-8
<i>Storage</i> . . . . .	.3-9

## SAFETY NOTIFICATION

**Please read this entire manual before the assembly or operation of this helical gearbox to make sure all safety considerations have been exercised and that care and concern for persons and equipment have been fully understood.**

- 1) Failure to adhere to the instructions in this operating manual may result in severe or fatal injuries. During the operation of this unit, please take all necessary actions to protect personnel from all moving, rotating, and high temperature sections to avoid harm to personnel. There is a risk of burns caused by hot surfaces when this product is in use. Use properly rated protective gear when working with these products.
- 2) Only qualified personnel should transport, store, install, assemble, connect, start-up, operate and maintain this unit.
- 3) When you receive the helical gearbox, please check the outside packaging first. If damage is apparent from shipping and transportation, please refuse shipment from the carrier and contact AutomationDirect customer service immediately for unit replacement. Never install and operate damaged products.
- 4) Before lifting, please make sure the lifting equipment for this unit is properly rated for the weight load of this equipment.
- 5) Use the unit only for its intended purpose.
- 6) Never operate the unit without the necessary protection covers or housing firmly in place.

## INSTALLATION

**Improper installation will cause damage to the helical gearbox. Please familiarize yourself with the entire set of installation instructions before starting installation.**

- 1) Clean all dirt from the surface of the shaft or flange before installation. During cleaning, be careful not to get cleaning solvents on any seals as cleaning solvents may damage the seals and void product limited warranty.
- 2) The helical gearbox can be placed in any of five install positions (M1, M3, M4, M5 or M6). Position M2 is not permitted. See **MOUNTING POSITIONS** ([page 3-4](#)) for the definition of mounting positions.
- 3) The helical gearbox should be installed on a stable foundation.  
The installation location should provide good air ventilation for the unit and allow for convenience of oil filling/ draining for proper ongoing unit maintenance.
- 4) Foundation flatness specifications.
  - Mounting footprint length  $\leq 230 - 0.1\text{mm}$
  - $230 < \text{Mounting footprint length} \leq 440 - 0.2\text{mm}$
  - $440 < \text{Mounting footprint length} \leq 500 - 0.4\text{mm}$
  - $500 < \text{Mounting footprint length} \leq \quad - 0.6\text{mm}$
- 5) IronHorse helical gearboxes are designed to be connected to NEMA frame motors. The connection to the motor is a quill style mount. Please note that some flange sizes will extend below the base of the helical gearbox.
- 6) After the installation, please turn the input shaft manually to avoid a dead-lock condition.
- 7) The unit is shipped with a vent plug in the filler location for mounting positions M1 and M3. If required, move the vent plug to the filter location as shown on the following page.
- 8) If the vent plug is white plastic, remove the red pin before operating the gearbox. If it is brass, pull off the rubber strap as shown below.

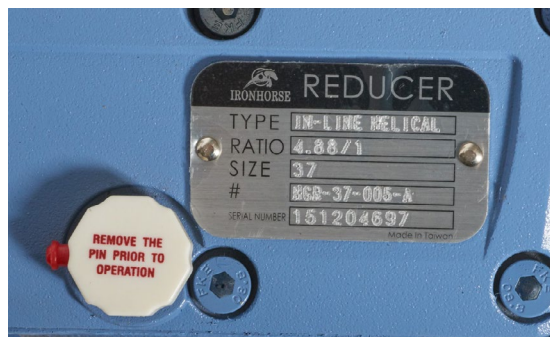

*Plastic vent plug*



*Brass vent plug*



*Brass vent plug - readied for use*

## MOUNTING POSITIONS

M1

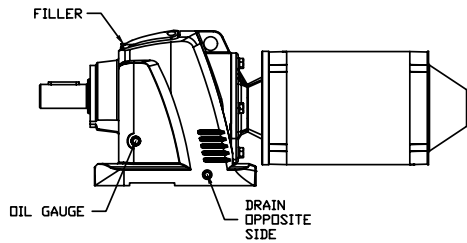

M2\*

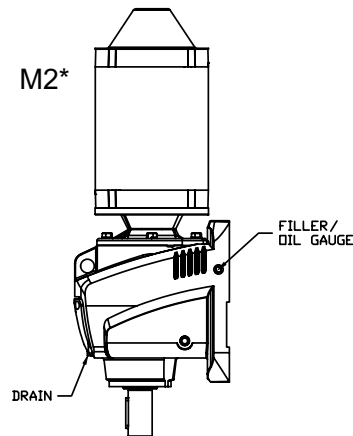

M3

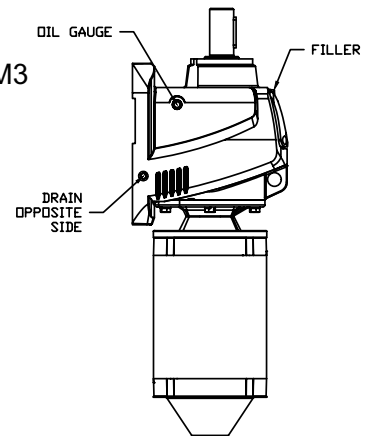

M4

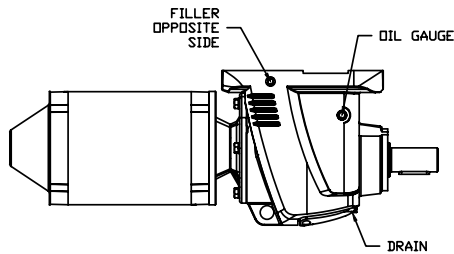

M5

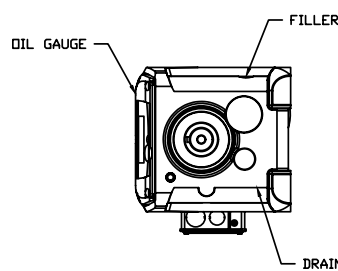

M6

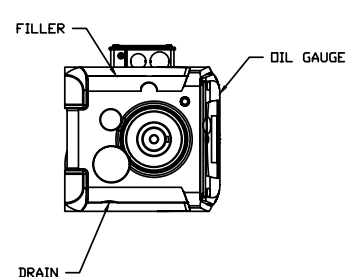

**\*NOTE:** Mounting position M2 is not permitted.

## STARTING UP

- 1) Check oil level before starting up. See the Lubrication section for instructions on proper unit lubrication.
- 2) Run In Procedure - IronHorse helical gearboxes do not require a run in procedure; however, the oil should be changed after the first 300 hours of operation.

## INSPECTION AND MAINTENANCE

**Please check the oil quality and change it regularly.**

- 1) The oil should be changed after the first 300 hours of use. After that, the oil should be changed every 2500 hours or 6 months, whichever occurs first.
- 2) Regularly inspect all seals for leaking. Seal sizes are listed later in this chapter ([page 3-8](#)).
- 3) Listen for excessive noise during regular operation. Noise coming from the unit may indicate a broken bearing. Discontinue use until bearings have been replaced. Bearing sizes are listed later in this chapter ([page 3-8](#)).
- 4) Regularly check the breather valve holes of the helical gearbox and make sure all openings are unclogged and free of debris. The exterior of the helical inline unit should be kept clean. The unit housing dissipates heat and must be kept free of debris to reduce heat buildup.
- 5) Check installation bolts regularly and tighten as required.
- 6) Any parts used should be equivalent to the original factory standards. When parts are used, a running test should be conducted without a load before the unit is returned to operation.
- 7) This equipment requires regular maintenance. Keep a log of oil changes and bolt tightening. Log any equipment issues and all corrective actions taken for warranty records.



**LUBRICATION**

- 1) All IronHorse helical gearboxes are initially filled with the proper quantity lubricant for an M1 mounting position. If you want to change the assembly mounting position, please move the breather plug, oil gauge and drain plug to the correct position and fill or decrease the quantity of oil to the correct fill level specifications. The breather plug should always be located at the highest point above the oil fill level.
- 2) A certain brand and specification of oil is required and unique to a particular helical gearbox. Be sure not to mix different brands and specification types of oil. IronHorse helical gearboxes are shipped with CPC HD320 oil. Oil suggestions for IronHorse units are as follows:

<b>IronHorse Helical Gearbox Lubricant Selection</b>				
<b>Standard Load / Input 600 RPM or Over 600 RPM</b>				
<b>Standard Load &lt; 1.25 service factor (see Chapter 2 for details)</b>				
<b>Gearbox Temperature</b>	<b>CPC</b>	<b>ISO VG</b>	<b>Mobil</b>	<b>Shell</b>
-30°C to -15°C	HD100	VG100	Mobilgear 627	Omala 100
-15°C to -3°C	HD150	VG150	Mobilgear 629	Omala 150
-3°C to 23°C	HD220	VG220	Mobilgear 630	Omala 220
23°C to 40°C	HD320	VG320	Mobilgear 632	Omala 320
40°C to 80°C	HD460	VG460	Mobilgear 634	Omala 460
<b>Heavy Load / Input 600 RPM or Over 600 RPM</b>				
<b>Heavy Load &gt; 1.25 service factor (see Chapter 2 for details)</b>				
-30°C to -15°C	HD150	VG150	Mobilgear 629	Omala 150
-15°C to -3°C	HD220	VG220	Mobilgear 630	Omala 220
-3°C to 23°C	HD320	VG320	Mobilgear 632	Omala 320
23°C to 40°C	HD460	VG460	Mobilgear 634	Omala 460
40°C to 80°C	HD680	VG680	Mobilgear 636	Omala 680

- 3) Before replacing the oil, the existing oil inside of gearbox should be drained and the unit should be cleaned up before filling with new oil.
- 4) During operation, if the units heats up over 80°C or if any abnormal noise occurs, please shut down the unit immediately. Check for proper oil fill, oil type, leaking seals and broken bearings and fix or replace as necessary before restarting the unit again. Do not run the unit if problems exist.

## FILLER / OIL GAUGE / DRAIN PLUG LOCATIONS

All IronHorse helical gearboxes have six (6) filler/oil gauge/drain plugs. The six plugs are located in different locations depending on the actual box size selected. Filler / gauge / drain plug locations, are shown below. Units are shipped configured for an M1 mounting position. Refer to the section **MOUNTING POSITIONS** in this chapter to see the location of the filler / gauge / drain plug locations for each different mounting position. If the mounting position is changed, the oil drain plug should always be placed in the lowest position after a new mounting position is selected.

The **Recommended Lubricant by Box Size and Mounting Position** table in this chapter lists the proper amount of oil for each mounting position. Oil fill amount is listed in liters.

When filling the gearbox with oil remove the oil gauge plug. Add oil until it begins to come out of the oil gauge plug. Replace the oil gauge plug and the fill plug. The gearbox now has enough oil inside.

When changing the oil, it may not be possible to remove all of the existing oil without disconnecting and lifting the unit. If lifting the unit is possible, simply lift the unit with proper lifting equipment, lower the drain plug by tilting the unit sideways, and gently shake the unit until all of the existing oil is removed.

The white cap shown below is a breather plug and should always be located in the filler position on the gearbox. If the gearbox is used in a position other than M1, the breather plug will need to be moved to the filler position after the new mounting is completed.



**NOTE:** *The breather plug should always be placed in the filler position. When filling the gearbox with oil, remove the breather plug, fill the oil and re-install the breather plug.*

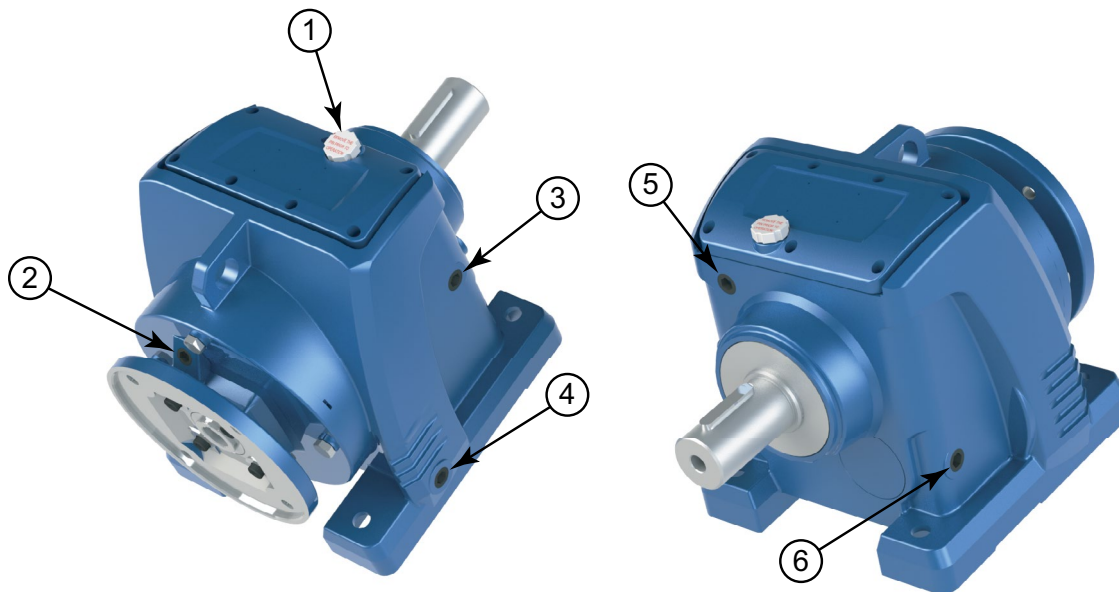

**RECOMMENDED LUBRICANT**

**CPC E.P. LUBRICANT HD**

CPC E.P. Lubricants HD are made of the highly refined base oils and special additives, including EP(extreme pressure) additives, anti-oxidation, anti-rust, anti-foamer, etc., with very good metal surface adhesion. These oils also contain sulfur-phosphorus EP additive to form tenacious oil film on metal surfaces that can endure high E.P. and vibration load to prevent gear surface over-heat and serious wear. These oils pass FZG gear test (DIN 51354) with pass load stage 12+.

These oils possess very excellent oxidative stability, and thus can effectively prevent gum formation and oil degradation for extended service. These oils are suitable for lubrication of heavily loaded bearings and gears.

CPC E.P. Lubricants are available in three packages:

- Bulk (HD320, HD460, and HD680)
- 200 liter drum
- 19 liter pail (HD150, HD220, HD320 and HD460)

CPC E.P. Lubricants HD Specifications								
Grade Number	HD32	HD68	HD100	HD150	HD220	HD320	HD460	HD680
Gravity, API, 15.6°C	30.4	28.5	27.8	27.1	26.5	25.9	25.3	24.4
Viscosity, Kin., cSt @ 40°C	31.15	67.2	98.1	143.6	212.2	310.5	440.4	656.2
Viscosity, Kin., cSt @ 100°C	5.26	8.62	11.16	14.38	18.59	23.70	29.80	38.68
Viscosity Index	99	99	99	98	97	96	96	96
Pour Point, °C	-18	-18	-18	-18	-18	-18	-18	-12
Flash Point, COC, °C	224	240	256	264	278	290	310	316
Color, D1500	L3.0	3.0	L4.0	4.0	L4.5	4.5	4.5	L5.0
TAN, mgKOH/g	0.75	0.75	0.75	0.75	0.75	0.75	0.75	0.75
Timken EP, OK Load, Lbs	65	65	65	65	65	65	65	70
Carbon Residue, Rams., %	0.25	0.27	0.34	0.40	0.45	0.51	0.56	0.64
Sulfated Ash, %	0.04	0.04	0.04	0.04	0.04	0.04	0.04	0.04
Product No.	LA82032	LA82068	LA82100	LA82150	LA82220	LA82320	LA82460	LA82680

**RECOMMENDED LUBRICANT AMOUNT BY BOX SIZE AND MOUNTING POSITION**

Mounting Position	Lubricant Amount (Liters)				
	Box Size				
	37	47	67	77	87
<b>M1</b>	0.30	0.70	1.10	1.20	2.30
<b>M3</b>	0.85	1.60	1.60	3.80	6.70
<b>M4</b>	0.95	1.50	2.80	3.60	7.20
<b>M5</b>	0.95	1.50	2.00	3.40	6.50
<b>M6</b>	0.75	1.50	1.80	2.50	6.30



**NOTE:** Oil fill volumes are approximate. To prevent damage to the gearbox fill the gearbox to the correct oil level and recheck after one week of use.

**SEAL SIZES**

<b>IronHorse Helical Inline Gearbox Seal Sizes</b>		
<b><i>Gearbox Model</i></b>	<b><i>Input Seal Size [mm]</i></b>	<b><i>Output Seal Size [mm]</i></b>
<b><i>HGR-37-xxx-A</i></b>	30x47x6	35x62x11
<b><i>HGR-37-xxx-B</i></b>	40x55x8	35x62x11
<b><i>HGR-47-xxx-A</i></b>	30x47x6	40x72x10
<b><i>HGR-47-xxx-B</i></b>	40x55x8	40x72x10
<b><i>HGR-47-xxx-C</i></b>	45x60x7	40x72x10
<b><i>HGR-67-xxx-A</i></b>	30x47x6	50x80x12
<b><i>HGR-67-xxx-B</i></b>	40x55x8	50x80x12
<b><i>HGR-67-xxx-C</i></b>	45x60x7	50x80x12
<b><i>HGR-77-xxx-B</i></b>	40x55x8	55x85x12
<b><i>HGR-77-xxx-C</i></b>	45x60x7	55x85x12
<b><i>HGR-77-xxx-D</i></b>	55x80x10	55x85x12
<b><i>HGR-87-xxx-B</i></b>	40x55x8	65x120x15
<b><i>HGR-87-xxx-C</i></b>	45x60x7	65x120x15
<b><i>HGR-87-xxx-D</i></b>	55x80x10	65x120x15
<b><i>HGR-87-xxx-E</i></b>	65x90x12	65x120x15

**BEARING SIZES**

<b>IronHorse Helical Inline Gearbox Bearing Sizes</b>		
<b><i>Gearbox Model</i></b>	<b><i>Input Bearings (2 required)</i></b>	<b><i>Output Bearings (2 required)</i></b>
<b><i>HGR-37-xxx-A</i></b>	6006ZZ	6205 + 6206ZZ
<b><i>HGR-37-xxx-B</i></b>	6008ZZ	6205 + 6206ZZ
<b><i>HGR-47-xxx-A</i></b>	6006ZZ	6206 + 6207ZZ
<b><i>HGR-47-xxx-B</i></b>	6008ZZ	6206 + 6207ZZ
<b><i>HGR-47-xxx-C</i></b>	6009ZZ	6206 + 6207ZZ
<b><i>HGR-67-xxx-A</i></b>	6006ZZ	6206 + 6208ZZ
<b><i>HGR-67-xxx-B</i></b>	6008ZZ	6206 + 6208ZZ
<b><i>HGR-67-xxx-C</i></b>	6009ZZ	6206 + 6208ZZ
<b><i>HGR-77-xxx-B</i></b>	6008ZZ	6207 + 6208ZZ
<b><i>HGR-77-xxx-C</i></b>	6009ZZ	6207 + 6208ZZ
<b><i>HGR-77-xxx-D</i></b>	6210ZZ + 6211ZZ	6210 + 6311ZZ
<b><i>HGR-87-xxx-B</i></b>	6008ZZ	6210 + 6311ZZ
<b><i>HGR-87-xxx-C</i></b>	6009ZZ	6210 + 6311ZZ
<b><i>HGR-87-xxx-D</i></b>	6210ZZ + 6211ZZ	6210 + 6311ZZ
<b><i>HGR-87-xxx-E</i></b>	6212ZZ + 6213ZZ	6210 + 6311ZZ

## STORAGE

**If the helical gearbox won't be used immediately and needs to be placed in storage for a period of time that exceeds six months, please pay attention to the special storage instructions outlined below.**

- 1) If the gearbox is to be placed in long term storage, care should be taken by applying anti-corrosion inhibitors on all non-coated parts, including the input shaft, output shaft, flange, and foot mounts. Units should be stored under a water proof cover and care should be taken to keep the units free of dust and debris.
- 2) All units should be stored in a dry, dust free environment. Avoid exposing the units to sunlight during storage.
- 3) All units should be stored in a temperature controlled environment, between 5° and 40°C (41° and 104°F).
- 4) If the storage time exceeds 2 years, please inspect units carefully before use. Units should be examined for rust. Units with rust should not be placed into operation. Check all bearings, seals, oil fill levels and oil specifications before use. Refer to the Lubrication section for proper oil specifications.

**BLANK  
PAGE**



**APPENDIX**

**A**

**GLOSSARY OF TERMS**

---

TABLE OF CONTENTS

*Glossary of Gearbox Terms* . . . . . A-2

## GLOSSARY OF GEARBOX TERMS

### **AXIAL MOVEMENT**

Often called “endplay.” The endwise movement of motor or gear shafts. Usually expressed in thousandths of an inch.

### **BACK DRIVING**

Driving the output shaft of a gearbox to increase speed rather than reduce speed. Helical gearboxes are not suitable for service to increase speed.

### **BACKLASH**

Rotational movement of the output shaft clockwise and counter clockwise, while holding the input shaft stationary. Usually expressed in thousandths of an inch and measured at a specific radius at the output shaft.

### **EFFICIENCY**

A ratio of the input power compared to the output power, usually expressed as a percentage.

### **FLANGED REDUCER**

Usually used to refer to a gearbox having provisions for close coupling of a motor either via a hollow (quill) shaft or flexible coupling. Most often a NEMA C-face motor is used.

### **GEARBOX**

Also called a Speed Reducer. An enclosed set of gears used in mechanical power transmission to reduce speed and increase torque.

### **HELICAL GEAR**

Parallel axis gear that features teeth that are cut at an angle to allow for smooth and quiet operation.

### **INPUT POWER**

The power applied to the input shaft of a gearbox. There are separate ratings for Mechanical Input Power, Thermal Input Power, and Nominal Motor Horsepower.

### **K FACTOR**

Also called an Overhung Load Factor. A constant used to modify the overhung load rating of a gearbox based on the type of load applied on the shaft. Use the K factor either to increase the calculated overhung load, or to reduce the gearbox overhung load rating.

### **MECHANICAL RATINGS**

The maximum power or torque a gearbox can transmit based on the strength and durability of its components. Some applications require the gearbox Mechanical Ratings to be reduced by a Service Factor.

### **MOUNTING POSITION**

The relationship of the input and output shafts of a gearbox relative to horizontal.

### **NOMINAL MOTOR HORSEPOWER**

The highest horsepower 1800 rpm motor that can be used with the gearbox under 1.0 service factor conditions. This rating decreases as the motor speed decreases, and as the service factor increases.

### **OUTPUT HORSEPOWER**

The amount of horsepower available at the output shaft of a gearbox. Output horsepower is always less than the input horsepower due to the efficiency of the gearbox.



**OVERHUNG LOAD**

A force applied at right angles to a shaft beyond its outermost bearing. This shaft-bending load must be supported by the bearing. Overhung load ratings are listed for each gearbox size, and should not be exceeded. Some applications require the gearbox Overhung Load rating to be reduced by a K Factor and/or a Service Factor.

**OVERHUNG LOAD FACTOR**

Also called K Factor. A constant used to modify the overhung load rating of a gearbox based on the type of load applied on the shaft. Use the Overhung Load Factor either to increase the calculated overhung load, or to reduce the gearbox overhung load rating.

**PRIME MOVER**

In industry, the prime mover is most often an electric motor. Occasionally engines, hydraulic or air motors are used. Special considerations are called for when other than an electric motor is the prime mover.

**SELF-LOCKING**

The inability of a reducer to be driven backwards by its load. No IronHorse helical gearbox should be considered self-locking.

**SERVICE FACTOR (FOR GEARBOX)**

A constant used to modify the Mechanical Rating of a gearbox based on the duration of service and characteristics of the driven load. Use the Service Factor either as a multiplier to increase the calculated loads, or as a divisor to reduce the gearbox Mechanical and Overhung Load ratings.

**SERVICE FACTOR (FOR MOTORS)**

Refers to a motor's ability to handle a load greater than the motor's rated horsepower on a continuous basis.

**SPEED REDUCER**

Also called a Gearbox. An enclosed set of gears used in mechanical power transmission to reduce speed and increase torque.

**THERMAL RATINGS**

The power or torque a gearbox can transmit continuously. These ratings are based upon the cast-iron gearbox's ability to dissipate the heat caused by friction.

**THRUST LOAD**

Forces along the axis of the output shaft, usually encountered in vertical-drive applications.

**BLANK  
PAGE**

# GEARBOX SELECTION

---

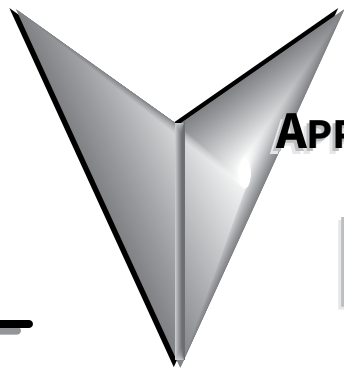

## APPENDIX

# B

### TABLE OF CONTENTS

<i>Gearbox Selection Procedure</i> . . . . .	B-2
<i>Gearbox Selection Steps</i> . . . . .	B-2
<i>Gearbox Selection Example</i> . . . . .	B-2

## GEARBOX SELECTION PROCEDURE

### GEARBOX SELECTION STEPS

- 1) Determine the torque and speed required for the load.
- 2) Determine the overall speed ratio of motor speed to load speed.
- 3) Determine the gearbox ratio as well as any reduction outside the gearbox (pulleys, gears, etc.).
- 4) Determine the applicable service factor and overhung load K factor.
- 5) Determine the gearbox real output torque required, and select a gearbox with a higher Maximum Thermal output Torque rating.
- 6) Determine the gearbox design output torque required (torque with service factor applied), and select a gearbox with a higher Maximum Mechanical Output Torque rating. (Gearbox must also meet requirement #5.)
- 7) Determine the required sizes of pulleys, gears, etc., and determine the overhung load force. Select a gearbox with a higher Overhung Load rating. (Gearbox must also meet requirements #5 & #6.)
- 8) Confirm that the selected gearbox meets the applicable system requirements.
- 9) Select a compatible motor.

### GEARBOX SELECTION EXAMPLE

**(Refer to the specifications tables for gearbox specifications, service factors, and K factors.)**

A conveyor will run 8 hours/day with moderate shock loading. The conveyor will be driven by a v-belt and needs to be driven approximately 30 rpm. The motor used will have a nominal speed of 1800 rpm (1750 rpm actual speed). The conveyor will require 5500 in·lb of torque.

- 1) Required torque = 5500 in·lb; required speed = 30 rpm.
- 2) Determine the overall speed ratio of motor speed to load speed:  
Overall speed ratio = (motor speed) / (load speed) = 1750 / 30 = 58.33 (about 58:1)
- 3) Determine pulley ratios at available gearbox ratios:  

$$\text{Gearbox ratio} = (\text{overall speed ratio}) / (\text{pulley ratio})$$

$$\text{Pulley ratio} = (\text{overall speed ratio}) / (\text{gearbox ratio})$$

$$= (\text{conveyor pulley diameter}) / (\text{gearbox pulley diameter})$$
  - For ~~5:1 gearbox~~: pulley ratio = 58.33 / 5 = ~~11.67~~ [11.67 pulley ratio too large]
  - For 10:1 gearbox: pulley ratio = 58.33 / 10 = 5.83
  - For 15:1 gearbox: pulley ratio = 58.33 / 15 = 3.89
  - For 20:1 gearbox: pulley ratio = 58.33 / 20 = 2.92
  - For 30:1 gearbox: pulley ratio = 58.33 / 30 = 1.94
  - For 40:1 gearbox: pulley ratio = 58.33 / 40 = 1.46
  - For ~~60:1 gearbox~~: pulley ratio = 58.33 / 60 = ~~0.97~~ [0.97 pulley ratio too small]
- 4) Determine service factor (SF) and overhung load factor (K) from applicable tables:  
 SF = 1.25 due to moderate shock loading and 3-10 hours/day operation  
 K = 1.5 due to V-belt

- 5) Use specification table to select gearbox with Max Output Torque Rating > required real torque:  
*Gearbox required real torque = (final torque) / (pulley ratio)*

For 10:1 gearbox:	$(5500 \text{ lb}\cdot\text{in}) / 5.83 = 943.40 \text{ lb}\cdot\text{in};$	use HGR-37-x or larger
For 15:1 gearbox:	$(5500 \text{ lb}\cdot\text{in}) / 3.89 = 1413.88 \text{ lb}\cdot\text{in};$	use HGR-37-x or larger
For 20:1 gearbox:	$(5500 \text{ lb}\cdot\text{in}) / 2.92 = 1883.56 \text{ lb}\cdot\text{in};$	use HGR-47-x or larger
For 30:1 gearbox:	$(5500 \text{ lb}\cdot\text{in}) / 1.94 = 2835.05 \text{ lb}\cdot\text{in};$	use HGR-67-x or larger
For 40:1 gearbox:	$(5500 \text{ lb}\cdot\text{in}) / 1.46 = 3767.12 \text{ lb}\cdot\text{in};$	use HGR-67-x or larger

- 6) Use specifications table to select gearbox with Max Output Torque Rating > required design torque:  
*Gearbox required design torque = (real gearbox torque)(service factor)*

For 10:1 gearbox:	$(943.40 \text{ lb}\cdot\text{in})(1.25) = 1179.25 \text{ lb}\cdot\text{in};$	use HGR-37-x or larger
For 15:1 gearbox:	$(1413.88 \text{ lb}\cdot\text{in})(1.25) = 1767.35 \text{ lb}\cdot\text{in};$	use HGR-47-x or larger
For 20:1 gearbox:	$(1883.56 \text{ lb}\cdot\text{in})(1.25) = 2354.45 \text{ lb}\cdot\text{in};$	use HGR-47-x or larger
For 30:1 gearbox:	$(2835.05 \text{ lb}\cdot\text{in})(1.25) = 3543.81 \text{ lb}\cdot\text{in};$	use HGR-67-x or larger
For 40:1 gearbox:	$(3767.12 \text{ lb}\cdot\text{in})(1.25) = 4708.90 \text{ lb}\cdot\text{in};$	use HGR-67-x or larger

- 7) Use the gearbox overhung load ratings from the specifications table to determine the minimum allowable pulley diameter.

Select gearbox with Overhung Load Rating > overhung load force:  
*Gearbox required OHL rating = (gearbox real torque)(K)(SF)/(gearbox pulley diameter / 2)*  
*Minimum gearbox pulley diameter = (T)(K)(SF)(2) / (OHL rating)*  
*Conveyor pulley diameter = (gearbox pulley diameter)(pulley ratio)*

For 10:1, HGR-37-010-x gearbox:

Minimum gearbox pulley diameter =  $(943.40 \text{ lb}\cdot\text{in})(1.5)(1.25)(2)/(388 \text{ lb}) = 9.12''$  (use 9.25")  
 Conveyor pulley diameter =  $(9.25'')(5.83) = \del{53.93''}  
**[pulley size is too large; try next higher gearbox ratio]**$

For 15:1, HGR-37-015-x gearbox:

Minimum gearbox pulley diameter =  $(1413.88 \text{ lb}\cdot\text{in})(1.5)(1.25)(2)/(451 \text{ lb}) = 11.76''$  (use 11.8")  
 Conveyor pulley diameter =  $(11.8'')(3.89) = \del{45.9''}  
**[pulley size is too large; try next higher gearbox ratio]**$

For 20:1, HGR-47-020-x gearbox:

Minimum gearbox pulley diameter =  $(1883.56 \text{ lb}\cdot\text{in})(1.5)(1.25)(2)/(690 \text{ lb}) = 10.24''$  (use 10.3")  
 Conveyor pulley diameter =  $(10.3'')(2.92) = \del{30.08''}  
**[pulley size is too large; try next higher gearbox ratio]**$

For 30:1, HGR-67-030-x gearbox:

Minimum gearbox pulley diameter =  $(2835.05 \text{ lb}\cdot\text{in})(1.5)(1.25)(2)/(1305 \text{ lb}) = 8.15''$  (use 8.5")  
 Conveyor pulley diameter =  $(8.5'')(1.94) = 16.5''$  (use 16.0")  
**Select HGR-67-030-x gearbox, 8.5" gearbox pulley and 16" conveyor pulley.**

For 40:1, HGR-67-040-x gearbox:

N/A – All gearboxes of the same frame size are the same price, yet the smaller ratio gearboxes offer higher efficiency and power characteristics than higher ratio gearboxes. Therefore, the HGR-67-030-x gearbox is preferable over the HGR-67-040-x gearbox for this application.

8) Check results against original speed and torque requirements:

*NOTE: Actual gearbox ratio is used from the specifications table.*

- a) Conveyor speed = (motor speed) / ((gearbox ratio)(pulley ratio))  
 = (1750 rpm) / (32.02)(16.0"/8.5") = 29.03 rpm
- b) Max real torque available at conveyor = (gearbox output torque)(pulley ratio)  
 = (5045 lb·in)(1.94) = 9787.3 lb·in
- c) Max design torque available at conveyor = (gearbox output torque)(pulley ratio)/SF  
 = (5045 lb·in)(16.0"/8.5") / 1.25 = 7829.8 lb·in

*The speed is very close to the required speed, and both maximum torque values are greater than the 5500 lb·in required by the load. Minor changes to pulley sizes can be tried to get conveyor speed closer to the required 30 rpm.*

9) Select a motor and check torque transmitted to the load:

From the gearbox spec tables, HGR-67-030-B efficiency = 94%

Max mechanical input power @ 1.0 SF = 4.83 hp

Max mechanical input power @ 1.25 SF

$$= (\text{max input power}) / (\text{SF}) = 4.83 \text{ hp} / 1.25 = 3.86 \text{ hp}$$

Max allowable motor power = 3.86 hp

The largest motor that HGR-67-030-B can accept is 2 hp.

Select 2 hp motor, and check for adequate torque at the load:

$\text{Torque} = \text{Power} / \text{Speed}$  [conversion factor: 1 hp = 63,025 lb·in·rpm]

$\text{Torque}_{\text{load}}$

$$= (63025 \text{ lb·in·rpm/hp})(\text{motor hp})(\text{gearbox efficiency}) / ((\text{motor rpm}) / ((\text{gearbox ratio})(\text{pulley ratio})))$$

$$= (63025)(2)(0.906) / (1750 / ((30)(16/8.5))) = 3685.15 \text{ lb·in} \text{ [insufficient torque at load]}$$

This torque value is less than the required 5500 lb·in required by the load.

Since a larger motor will not fit on the HGR-67-030-B, select HGR-77-030-C gearbox with a 3 hp motor.

From the gearbox spec tables, HGR-77-030-C efficiency = 90.7%

Max mechanical input power @ 1.0 SF = 6.36 hp

Max mechanical input power @ 1.25 SF = (max input power) / (SF)

$$= 6.36 \text{ hp} / 1.25 = 5.09 \text{ hp}$$

Max allowable motor power = 5.09 hp

The largest motor that HGR-77-030-C can accept is 5 hp.

Select 3 hp motor, and check for adequate torque at the load:

$$\text{Torque}_{\text{load}} = (63025)(3)(0.907) / (1750 / ((30)(16/8.5)))$$

$$= 5533.8 \text{ lb·in} > 5500 \text{ lb·in}$$

**Final Selection:            HGR-77-030-C gearbox            3 hp motor**

**BLANK  
PAGE**



IronHorse® Helical Gearbox User Manual  
Third Edition – 11/13/2019  
*IH-HGR\_UMW*